

# BATTLETECH<sup>®</sup> COMPENDIUM

THE RULES OF WARFARE





*"Life is cheap. BattleMechs are expensive." —Advertising slogan, Irian BattleMechs Ltd.*

Welcome to the year 3057. The Successor States of the Inner Sphere battle each other and their deadliest enemies, the invading Clans, in endless wars that rage across the known universe. These epic conflicts are won and lost by BattleMechs, 30-foot tall, humanoid titans of metal that pack enough firepower to destroy entire cities.

BattleTech celebrates its tenth anniversary with the **BattleTech Compendium: The Rules of Warfare**, the ultimate guide to combat in the 31st century. All the rules needed to simulate exciting conflicts between BattleMechs, vehicles, and infantry are included, revising and streamlining material from BattleTech, 3rd Edition, CityTech, 2nd Edition, and the original BattleTech Compendium. The Rules of Warfare also contains a concise history of the BattleTech universe and its movers and shakers, several new BattleMech and OmniMech designs, rules for miniatures play, and full-color illustrations.

**FASA**  
CORPORATION

**BATTLETECH®**

BATTLETECH® is a Registered Trademark of FASA Corporation.  
BATTLETECH COMPENDIUM: THE RULES OF WARFARE™ is a Trademark of FASA Corporation.  
Copyright © 1994 FASA Corporation. All Rights Reserved. Printed in the USA.



# **BATTLETECH<sup>®</sup>** **COMPENDIUM** **THE RULES OF WARFARE**

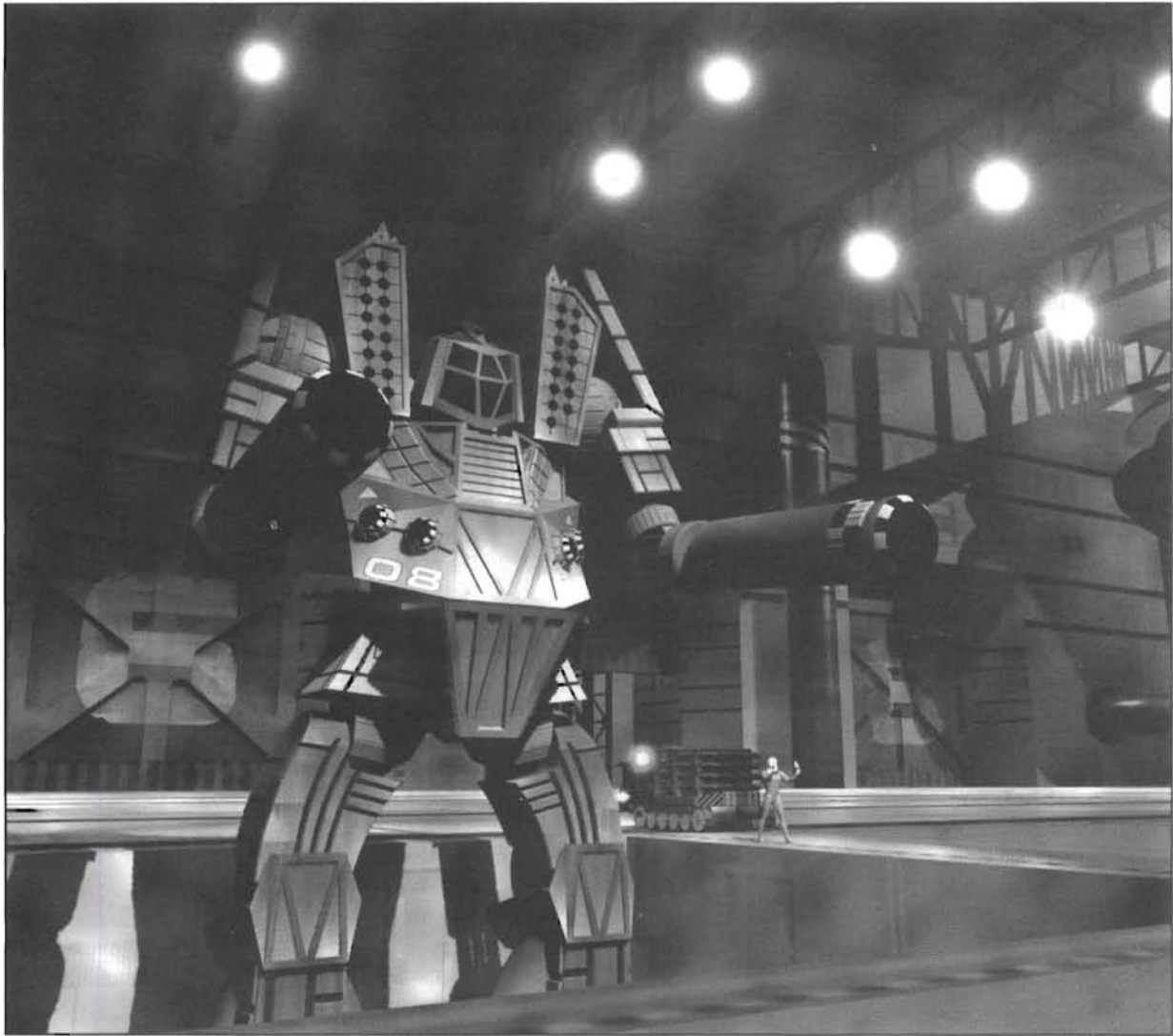

---

F A S A   C O R P O R A T I O N

---

# BATTLETECH COMPENDIUM

## TABLE OF CONTENTS

THE STORY SO FAR	6	Charging	47
INTRODUCTION	7	Death from Above	49
Level Two BattleTech	7	Different Elevations	50
COMPONENTS	8	Physical Attacks by Prone BattleMechs	51
Units	8	Accidental Falls from Above	51
Record Sheets	9	Domino Effect	51
Mapsheets	11	Heat	52
Counters	12	Heat Points	53
Dice	13	Effects of Heat	53
PLAYING THE GAME	14	BUILDINGS	56
Sequence of Play	14	Building Types	56
MechWarriors	15	Movement Effects	57
MechWarrior Skills	15	Combat Effects	58
Skill Improvement	17	Damage to Buildings	58
Damaging a MechWarrior	17	Damage to Units Inside	58
Consciousness Rolls	17	VEHICLES	60
MOVEMENT	18	Movement	60
Movement Costs	18	Combat	62
Movement Direction	18	INFANTRY	66
Movement Modes	19	Movement	66
Standing Still	19	Infantry Carriers	67
Walking/Cruising	20	Mechanized Battle Armor	67
Running/Flank Speed	20	Combat	67
Jumping	20	Standard Infantry Attacks	67
Facing	21	Damage to Standard Infantry	67
Facing Change	21	Battle Armor Attacks	68
Dropping to the Ground	21	Damage to Battle Armor	69
Road/Pavement Movement	21	Inner Sphere Battle Suits	69
Bridge Movement	21	SPECIAL CASE RULES	70
Skidding	23	Aerospace Support	70
Stacking	24	Game Set-Up	70
Standing Up	24	Fighter Movement	70
Torso Twist/Turret Rotation	24	Fighter Attack Types	72
Piloting Skill Rolls	24	Return Fire	75
Making Piloting Skill Rolls	25	Anti-BattleMech Infantry	75
Falling	26	Leg Attacks	76
COMBAT	30	Swarm Attacks	76
Weapon Attacks	30	Artillery	77
Line of Sight	30	Game Set-Up	77
Firing Arcs	33	Targeting	78
Firing Weapons	33	Damage	79
To-Hit Roll	38	Smoke Rounds	80
Hit Location	39	Onboard Artillery Fire	80
Damage	41	Basements	80
Critical Damage	41	BattleMech Lifting Capabilities	81
Destroying a Unit	45	Cargo Carriers	81
Ammunition Expenditures	45	Clearing Woods	81
Physical Attacks	45	Dropping Troops	82
Punching	45	Dumping Ammunition	83
Clubbing	46	Ejecting	83
Pushing	47	Fire	84
Kicking	47	Flak	86

# TABLE OF CONTENTS

<b>Four-Legged BattleMechs</b>	87		
<b>Gun Emplacements</b>	88		
<b>Hidden Units</b>	89		
<b>Hostile Environments</b>	89		
Extreme Temperatures	89		
Ice	89		
High/Low Gravity	90		
Swamp	91		
Vacuum	91		
<b>Improved Positions</b>	92		
<b>LRM Indirect Fire</b>	92		
<b>Minefields</b>	93		
Conventional Minefields	93		
Command-Detonated Minefields	93		
Vibrabomb Minefields	93		
Clearing Minefields	93		
<b>Night Combat</b>	94		
<b>Reversing Arms</b>	94		
<b>Scavenging and Repair</b>	94		
<b>Underwater Operations</b>	95		
<b>CONSTRUCTION</b>	99		
<b>BattleMech Construction</b>	99		
<b>Outfitting an OmniMech</b>	106		
<b>Vehicle Construction</b>	107		
<b>EQUIPMENT</b>	112		
Anti-Missile System	112		
Anti-Personnel Pods	112		
Arrow IV Missile Artillery System	113		
Artemis IV Fire-Control System	113		
Artillery Weapons	114		
Autocannon	114		
Beagle Active Probe	114		
C³ Computer	114		
Cargo Space	115		
Cellular Ammunition Storage Equipment (CASE)	115		
Endo Steel Internal Structure	116		
Ferro-Fibrous Armor	116		
Flamers	116		
Gauss Rifle	116		
Guardian ECM Suite	116		
Hatchet	117		
Heat Sinks	117		
Infernos	117		
LB-X Autocannon	118		
Laser	118		
Long-Range Missiles (LRM)	119		
Machine Gun	119		
Myomer Acceleration Signal Circuitry (MASC)	119		
Narc Missile Beacon	119		
Particle Projector Cannon (PPC)	119		
Pulse Lasers	120		
Short-Range Missiles (SRM)	120		
Single-Shot Missile Launchers	120		
Streak Short-Range Missiles	120		
Swarm Long-Range Missiles	120		
		Target Acquisition Gear (TAG)	120
		Targeting Computer	120
		Thunder Long-Range Missiles	121
		Torpedoes	121
		Triple-Strength Myomer	121
		Ultra Autocannon	122
		XL Engines	122
	<b>COSTS</b>		<b>123</b>
	<b>BattleMech Costs</b>		<b>123</b>
	<b>Infantry Costs</b>		<b>123</b>
	<b>Vehicle Costs</b>		<b>123</b>
	<b>TECHNICAL READOUT</b>		<b>125</b>
	<b>Inner Sphere Designs</b>		<b>125</b>
	<b>OmniMechs</b>		<b>129</b>
	<b>INDEX</b>		<b>133</b>
	<b>RECORD SHEETS</b>		<b>137</b>
	<b>REFERENCE TABLES</b>		<b>151</b>
	<b>MINIATURES RULES</b>		

# TABLE OF CONTENTS

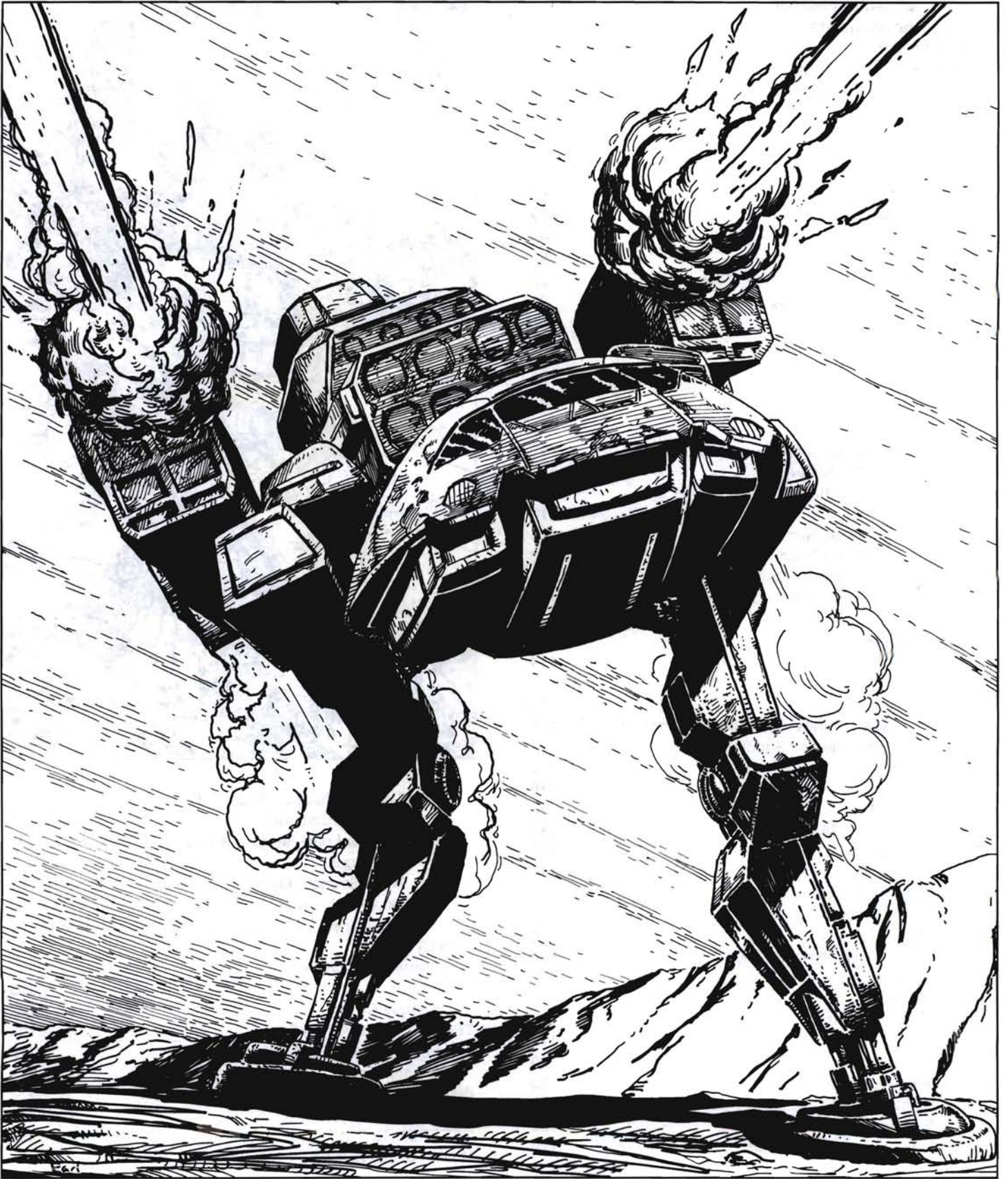

# CREDITS

## BATTLETECH COMPENDIUM: THE RULES OF WARFARE

### BattleTech Original Design

Jordan K. Weisman  
L. Ross Babcock III  
Sam Lewis

### Development

Bryan Nystul

### Additional Design and Development

Samuel B. Baker  
Forest G. Brown  
Chris Hartford  
Clare Hess  
Scott Jenkins  
J. Andrew Keith  
James R. Kellar  
Dale Kemper  
L.R. "Butch" Leeper  
Jim Long  
Michael Mulvihill  
Jim Musser  
Mike Nystul  
Blaine Pardoe  
Boy F. Petersen Jr.  
Jerry Stenson  
Wm. John Wheeler

### Miniatures Rules

Bryan LiBrandi  
Chuck Crane  
Ral Partha Enterprises

### Sidebars written by

Robert Cruz  
Diane Piron-Gelman  
Christopher Hussey  
Sam Lewis  
Michael Mulvihill  
Sharon Turner Mulvihill  
Bryan Nystul  
Michael A. Stackpole

### Editorial Staff

*Editorial Director*  
Donna Ippolito  
*Managing Editor*  
Sharon Turner Mulvihill  
*Associate Editors*  
Diane Piron-Gelman  
Robert Cruz

### Production Staff

*Art Director*  
Jim Nelson  
*Project Manager*  
Joel Biske  
*Cover Art*  
Doug Andersen  
*Cover Design*  
Jim Nelson  
*Black and White Illustrations*  
Joel Biske  
Earl Geier  
Mike Jackson  
Jeff Laubenstein  
John Paul Lona  
Duane Loose  
Larry MacDougall  
Jim Nelson  
Allen Nunis  
*Computer Color Plates*  
Carl Denham  
Dave McCoy  
Richard Paine  
*Color Section Designs*  
Joel Biske  
Mark Ernst  
Jim Nelson  
Mike Nielsen  
*Photos*  
Bryan LiBrandi  
Ral Partha Enterprises  
Steve Venters  
*Color Map*  
Mike Nielsen  
*Maps and Diagrams*  
Joel Biske  
*Layout*  
Steve Bryant  
*Production Assistant*  
Mark Ernst

### Playtesting of this edition

Vincent K. Bieksha, Brent Carter, Philip J. DeLuca  
Alan M. Gopin, Detlef Howe, Christopher Hussey  
Henry E. Mergner, Jr., John L. "Jack" Nelson, Bob Nicholls  
Eric J. Smith

### Playtesting of previous editions

Far too many to mention individually. (Sorry folks.)

### Special Thanks

MechForce NA, MechForce UK, and MechForce Germany for their unending support, and to all the people on GENIE and America OnLine

BATTLETECH®, MECH®, BATTLEMECH®, and MECHWARRIOR® are Trademarks of FASA Corporation, registered in the U. S. Patent and Trademark Office. Copyright © 1994 FASA Corporation. All Rights Reserved. Printed in the U. S. A.  
Published by FASA Corporation • 1100 W. Cermak • Suite B305 • Chicago, IL • 60608

Third Printing, September 1995

## THE STORY SO FAR



After millenia of war, humankind's fragile hope for peace is drowning in blood. The giant BattleMech rules the battlefield, and conflict rages across almost every human world—including Terra, the cradle of the human race. Humanity's homeworld has fallen to religious fanatics, the ComStar renegades who call themselves the Word of Blake. The vast and powerful Federated Commonwealth, once the Inner Sphere's best hope of peace and prosperity in a new Star League, exists only as a paper state besieged by ancient enemies. The Clans, who invaded the Inner Sphere from the Periphery and took world after world in a seemingly unstoppable wave of conquest, have grimly endured four years of peace after their defeat on the world of Tukayyid—the signers of the fifteen-year Truce of Tukayyid now stand accused of treason. Clan Wolf has fallen—now the Crusaders rule, ready to break the truce and conquer the Inner Sphere with fire and sword.

The first crack in the crumbling foundation of the Federated Commonwealth came with the abortive Skye Rebellion. Though the rebellion's leader died, the passions he inspired live on in Lyran hearts. Now Archon Prince Victor Steiner-Davion battles the invasion of his realm by Liao and Marik forces, but with only half his empire's strength—Katrina Steiner-Davion, ruler of the Lyran worlds, has torn them away from her brother's grasp and created the independent Lyran Alliance. The Capellan Confederation and the Free Worlds League are taking world after Commonwealth world, and Victor can do little to stop them.

To avenge the death of his son and Prince Victor's attempt to replace the boy with an impostor, Captain-General Thomas Marik of the Free Worlds League struck hard at a host of Davion planets. In support of Marik, Chancellor Sun-Tzu Liao of

the Capellan Confederation has invaded the Federated Commonwealth to take back the worlds wrested from his nation during the Fourth Succession War. A canny politician with an obsessive hatred of Victor, Sun-Tzu will stop at nothing to destroy his enemy. But even as Sun-Tzu plots to use Marik's war for his own ends, the Captain-General is using Sun-Tzu's ambitions to further House Marik's cause.

The upheaval has even touched the very heart of known space. On Commonwealth worlds near Terra, the Marik-Liao onslaught and the secession of the Lyran Alliance has blown the lid off simmering hatred between countless factions, and vultures squabble over the scraps of power while ordinary people suffer. The so-called Chaos March is a no-man's land, where the fighting never stops and loyalty can mean death.

The Clans, too, have erupted in conflict. Ulric Kerensky, accused of treason by his fellow Clansmen for agreeing to the Truce of Tukayyid, which halted the invasion of the Inner Sphere, has turned Clan Wolf's Trial of Refusal into an all-out war against Clan Jade Falcon. The titanic Clan battle shattered the Wolf Clan and killed both Ulric and Clan Wolf's senior Khan, Natasha Kerensky. With the Wolves' tempering influence gone, the Crusaders among the Clans have the power as well as the will to destroy the Inner Sphere.

The Successor States' only hope for survival lies with the Draconis Combine. The Combine's Coordinator, Theodore Kurita, is quietly gathering the Inner Sphere's finest mercenary units and sending them out to search for the hidden Clan homeworlds. If Theodore's desperate gambit succeeds, the Inner Sphere can carry the war to the Clans' doorstep and may yet triumph ... if its forces can survive.

## INTRODUCTION

The **BattleTech Compendium: Rules of Warfare** is the single-source rulebook for people who play **BattleTech**. The **Rules of Warfare** includes all the rules presented in the **BattleTech** and **CityTech** games, as well as those introduced in various **Technical Readouts** and other sourcebooks. These rules supersede all previously published rules, including the original **BattleTech Compendium**; **BattleTech, Third Edition**; and **CityTech, Second Edition**.

The **Rules of Warfare** celebrates the tenth anniversary of the **BattleTech** game and provides clarifications of published rules. Most of the changes included in these rules are the direct result of players' letters and calls asking FASA to clarify and tidy up the rules of **BattleTech**. In general, most changes made to the rules consist of rephrasing to clear up any confusion or ambiguities. We at FASA feel confident that these are the most complete, clear, and concise rules for **BattleTech** ever presented. The **AeroTech** rules from the original **BattleTech Compendium** do not appear in this volume because **Rules of Warfare** is intended only as a ground-based combat game.

For experienced players who do not wish to reread all the rules, sections that contain significant clarifications or changes from the **BattleTech Compendium** are marked with this symbol: ◆

We recommend that even experienced players read these sections.

To play **BattleTech**, players will need dice, maps, and counters or miniatures to represent the BattleMechs and/or vehicles used by each side. For more information about the availability and use of these items, see **Components**, p. 8 of this book.

### LEVEL TWO BATTLETECH

Beginning with the publication of the **BattleTech Tactical Handbook**, all **BattleTech** rules now carry a Level One, Level Two, or Level Three designation. Level One **BattleTech** represents the basic level of play described in the **BattleTech, Third Edition** boxed set and uses the technology available in 3025—all 'Mechs, vehicles, and weapons described in **Technical Readouts 3025** and **3026**.

Level Two **BattleTech** represents the rules used in all tournaments and MechForce-level competition. Level Two **BattleTech** is defined by the rules contained in the **BattleTech Compendium: Rules of Warfare**. All the rules in this book are Level Two, which includes all Level One rules, those rules found in the **CityTech, Second Edition** boxed set, and the technology available in 3055—the 'Mechs, vehicles, equipment, and other technology described in **Technical Readouts 2750, 3050, 3055**, and all previous tech readouts.

Level Three **BattleTech** play may include any of the optional rules presented in the **Tactical Handbook**, as well as the experimental technology included in the **MechWarrior**



adventure **Unbound**. Level Three rules are optional rules that players may use as they see fit. The rules for Land-Air 'Mechs (LAMs) now appear in the **Tactical Handbook** as Level Three rules, which makes them illegal for tournament play.

## COMPONENTS

The game of **BattleTech** simulates combat between single BattleMechs, vehicles, or infantry units on a variety of terrain. This chapter describes the various combat units that compete on the **BattleTech** battlefield and the various record sheets and maps needed to play the game.

### UNITS

In these rules, the term *unit* refers to any combat unit—BattleMech, vehicle, infantry platoon, or battle armor Point. During game play, units are best represented by miniatures. A complete line of **BattleTech** miniatures is available from **Ral Partha** (see **Miniatures Rules** for photos of some of these miniatures). FASA also produces plastic miniatures for certain boxed games, such as **BattleTech, Third Edition**. If miniatures are unavailable, players may use counters or any other item to represent each unit, as long as it is clear which way each unit is facing at all times.

### BATTLEMECHS



BattleMechs—the most powerful war machines ever built—dominate the battlefields of the 31st century. These huge, man-shaped vehicles are faster, more maneuverable, better armored, and more heavily armed than any other combat unit. Equipped with particle projector cannons, lasers, rapid-fire autocannons, and missiles, these behemoths pack enough firepower to flatten everything but another 'Mech.

Armies of the 31st century field two classes of BattleMechs: those used primarily by the Inner Sphere, representing variations of and improvements on the original 'Mech technology, and the unique machines that give the Clans their edge, known as OmniMechs.

### VEHICLES

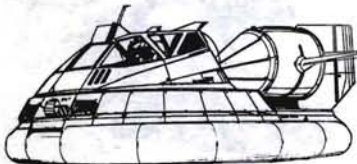

Most armies choose to use their BattleMech resources sparingly when they can, and so maintain forces of more conventional vehicles to serve in low-intensity conflicts and as auxiliaries to BattleMech units.

#### Ground Vehicles

The Inner Sphere armies of the thirty-first century deploy three types of ground vehicles: tracked, wheeled, and hovercraft.

**Tracked:** Because they move using continuous caterpillar treads, these vehicles are normally referred to as tanks, though

the original meaning of this term has been lost in antiquity. The treads allow these vehicles to move easily through virtually every type of terrain an army may encounter on any planet. Commonly armed with turret-mounted heavy weapons, some of the heaviest vehicles of this class can inflict a great deal of damage, even to a BattleMech.

**Wheeled:** Wheeled vehicles move faster than tracked vehicles while still mounting effective weapons. These vehicles suffer serious terrain restrictions, however, and so commanders usually assign wheeled vehicles to relatively open terrain and cities to serve as convoy escorts or fire-support vehicles for dismounted infantry.

**Hovercraft:** Hovercraft are designed for speed. That feature, rather than their weak armor and light armament, serves to protect these rather fragile vehicles. Because hovercraft also cost more and require a higher technology base than tracked or wheeled vehicles, armies use them cautiously. Their ability to rapidly close with the enemy and just as rapidly break contact, however, makes these units highly valued for reconnaissance and screening missions.

#### Vertical Take-Off and Landing (VTOL)

Fast, deadly, and highly vulnerable to damage, VTOLs and their pilots suffer the highest mortality rate of any type of combat vehicle. The term VTOL refers to a variety of vertical take-off and landing vehicles whose primary mission is to support the battle on the ground, including conventional rotary-wing craft (helicopters), X-wing "stopped rotors" craft, and tilt-rotor aircraft (the engine mountings rotate in a 90-degree arc). Because of the high torque required for their operation, VTOL rotors cannot be heavily armored and so cannot absorb much combat damage. More VTOLs are destroyed by rotor hits than by any other type of damage.

#### Naval Vessels

Large-tonnage military naval vessels long ago gave way to the superiority of conventional and aerospace fighters. However, small vessels used for performing counterinsurgency work and defending underwater command posts still serve a unique and useful purpose.

**Surface Naval Vessels:** As the name implies, this class of vessel operates only on the surface of bodies of water. Surface vessels come in two types: those with a displacement hull, and hydrofoils. Vessels built with a displacement hull represent the cheapest, best protected, and best armed of all the naval vessels, but their conventional rounded hulls prevent these vessels from attaining the speed necessary to close quickly with an elusive enemy. Hydrofoils offer speed and punching power that displacement-hulled vessels lack. Featuring wings that lift the vessel's hull out of the water, these naval assets usually patrol coastlines and guerrilla-infested river deltas.

# COMPONENTS

**Submarines:** Technological advances allowed manufacturers to create ever-smaller submarines over the past several centuries, and these underwater vessels still reign supreme in the oceans of most worlds. In their home environment, these expensive and specialized vessels can reasonably expect to defeat an equivalent-weight BattleMech. Their commanders usually assign them to protect underwater installations and command centers.



## INFANTRY UNITS

The Inner Sphere and the Clans use two distinct infantry unit configurations. Unarmored infantry are organized into 28- or 21-man platoons. Battle-armored infantry form 5-man Points. When these rules refer to infantry, both unarmored infantry platoons and armored infantry Points use those rules. In specific rules for one or the other type of infantry unit, the terms *unarmored infantry* and *infantry platoon* refer to non-battle suited infantry; the terms *battle armor*, *armored infantry*, and *infantry Point* describe units wearing battle armor.

## Foot

Twenty-eight-man foot infantry platoons have no organic transportation, carry light arms, and cannot hope to successfully assault or defend against even the lightest BattleMech. Foot infantry generally provide population control, man city garrisons, and mount counterinsurgency operations. Though the start-up cost for such units seems relatively high, they cost very little to maintain. Infantry units are also useful because most planets can call up and arm thousands of foot infantry on short notice.

## Motorized

Equipped with a variety of light vehicles, motorized 28-man infantry platoons move about the battlefield more readily than foot infantry, but still are no match for BattleMechs. Motorized infantry units serve the same duties as foot infantry, and also serve as forward observers or reconnaissance personnel.

## Jump

The 21 men in a jump platoon are all equipped with jump packs. In open, flat terrain, this equipment makes jump infantry as mobile as motorized troops. In built-up areas, jump-capable troops are more mobile than any other type of infantry. Their jump capabilities allow these troops to close quickly with enemy units, but a close assault of this type can devastate both the defender and the attacker.

## Battle Armor

Battle-armored infantrymen wear powered suits of armor equipped with various weapons. Though some Inner Sphere units field battle-armored troops, such equipment remains rare and is less powerful than the Clan equivalent. Clan infantrymen, known as Elementals, are organized into 5-man Points. Their individually powered suits of armor mount missiles, small lasers, and anti-personnel weapons. Because Elemental armor can survive direct hits from BattleMech-class weapons, a single Point of battle armor can efficiently disable or destroy a 20-ton 'Mech.

## RECORD SHEETS

Players use the following record sheets to track various types of information while playing **BattleTech**. Each type of unit (BattleMech, vehicle, infantry, battle armor) uses a unique record sheet. A description of each record sheet appears below, and a blank copy of each appears at the end of this book. Permission is given to reproduce these record sheets for personal use.



## BATTLEMECH RECORD SHEET

Players use the BattleMech Record Sheet to track damage done to a BattleMech during combat. The same record sheet represents both regular 'Mechs and OmniMechs. The following information describes each section of the record sheet.

### Armor Diagram

The set of diagrams at the top of the record sheet is referred to as the Armor Diagram, and it shows the arrangement of armor plating on the BattleMech. Each circle (referred to as a box) represents a point of armor. Boxes in excess of a specific BattleMech's armor plating are filled in prior to play. As weapons hits destroy a 'Mech's armor, the player checks off the boxes by filling in the affected circles. The Armor Diagram shows the front and rear armor of the BattleMech's torso, the Internal Structure Diagram, and the Damage Transfer Diagram.

The Internal Structure Diagram shows the locations of the BattleMech's internal structures and is used to track damage to those locations. The Damage Transfer Diagram shows where damage will be taken or transferred when a part of the BattleMech already destroyed takes additional damage.

# COMPONENTS

## WOLFNET CLASSIFIED REPORT ALPHA LEVEL CLEARANCE

Welcome to the Wolfnet database. Learn to use it well; it could save your life someday.

If that sounds like a ridiculous exaggeration, think again. The single most important element in any battle, whether diplomatic or military, is information. Knowledge, far more than machines or eloquence, earns victory for those who employ it intelligently. Wolfnet exists for the sole purpose of gathering knowledge, and every byte of that information winds up in this database. To get a complete picture of the powers currently operating in known space, Wolfnet operatives look at everything, from coded transmissions to private letters to popular novels. As a Wolfnet operative, never assume you know what to save and what to discard. Anything may be important; read it, listen to it, consider it, and file it away.

Knowledge is power. Use it.  
—Major-General Margaret Tulliver  
Deputy Director, Wolfnet  
15 November 3056



### Mech Data

Located in the upper right corner, this section of the record sheet lists the BattleMech's most important statistics, including the BattleMech type, tonnage, movement, weapons inventory, and heat sink boxes.

### Warrior Data

This section lists the name, skills, and condition of the MechWarrior piloting the BattleMech.

### Critical Hit Table

The Critical Hit Table shows the physical location of the BattleMech's critical equipment, weapons, and ammunition. This table helps determine the location of any critical hit; each slot represents a particular weapon or other piece of equipment susceptible to destruction. Some equipment occupies so much space in the 'Mech that it requires multiple slots on the table.

### Heat Scale

The Heat Scale helps the player track the internal heat build-up in each BattleMech. As heat builds up, the player checks off these boxes from low to high. At certain levels of heat build-up, information in the right column of the scale describes the effect of the heat on the BattleMech's operation.

### VEHICLE RECORD SHEET

The Vehicle Record Sheet allows players to track damage done to individual vehicles during combat. Each type of vehicle (ground, VTOL, and naval) uses a different record sheet, but they all share the features described below.

### Armor Diagram

The Armor Diagram on the right-hand side of the record sheet shows the arrangement of the vehicle's armor plating and internal structure. As weapons hits destroy the armor, the player fills in the circles (checks off the boxes). When all the boxes in one section are filled in, damage transfers to the adjacent internal structure. The shaded areas of the Armor Diagram show the locations of the vehicle's internal structure.

### Vehicle Data

The Vehicle Data section lists the vehicle's other important statistics, including its tonnage, movement, weapons inventory, and other components. The player also records the pilot's Driving and Gunnery Skills here. Beneath the spaces for Driving Skill and Gunnery Skill, VTOL and submarine record sheets include a Turn Column and an Elevation Column, which the player uses to track the VTOL's elevation or the submarine's depth at the end of the vehicle's movement. The current elevation of a VTOL cannot be lower than the level of the terrain under the VTOL, nor can the current depth of a submarine be greater than the water's depth or less than 0.

### INFANTRY RECORD SHEET

		▼ Jump Platoons Start Here																											
		28	27	26	25	24	23	22	21	20	19	18	17	16	15	14	13	12	11	10	9	8	7	6	5	4	3	2	1
Rifle Platoon		7	7	7	6	6	6	5	5	5	4	4	4	4	3	3	3	3	2	2	2	2	1	1	1	1	1	1	1
Machine Gun or Flamer Platoon		10	9	9	8	8	8	7	7	7	6	6	6	5	5	5	4	4	4	3	3	3	2	2	2	1	1	1	1
Laser or SRM Platoon		14	14	13	13	12	12	11	11	10	10	9	9	8	8	7	7	6	6	5	5	4	4	3	3	2	2	1	1

# COMPONENTS

Infantry Record Sheets come four to a page and are used for all unarmored infantry platoons. Each record sheet has four rows. Use the top row to record the number of men in the unit. As the unit takes damage, check off these boxes to reflect the platoon's casualties. The remaining three rows show the damage that a specific unit can do, depending on the number of men in the platoon and the type of weapons the platoon is using. For example, a full-strength rifle platoon inflicts 7 points of damage each time it hits, while an 11-man laser platoon does 6.

The record sheet also reprints a Base To-Hit Number Table for each of a platoon's possible weapon types.

## BATTLE ARMOR RECORD SHEET

Each Battle Armor Record Sheet represents a Point of battle armor. Each of the sheet's five rows represents a single Elemental. As an Elemental takes damage, the player checks off the boxes in that trooper's row. When all the boxes are checked off, that Elemental is out of the battle. The record sheet also provides two boxes to track the unit's short-range missile salvos.

## MAPSHEETS

The 22-by-17-inch mapsheets used in **BattleTech** are divided into six-sided areas called hexes (short for hexagon). The players use these hexes to regulate movement and combat by moving units from hex to hex during a turn. Each hex on the mapsheet represents an area of ground 30 meters (roughly 100 feet) across.

The forests, rivers, hills, buildings, and rough areas on a **BattleTech** mapsheet represent a typical mixture of the terrain found on the habitable worlds of the Inner Sphere. The following symbols represent each type of terrain as described.

### CLEAR

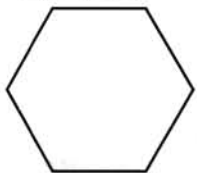

Clear terrain represents fields, meadows, and other grasslands. The ground is firm and may be gently rolling, but its elevation does not change significantly from one side of the hex to the other.

### ROUGH



Rough terrain represents broken, rocky, and jumbled ground. Though firm, this type of terrain generally proves more difficult to cross than Clear terrain. Commonly encountered near cliffs and bluffs, rough ground may also be formed as a result of combat.

### HILLS

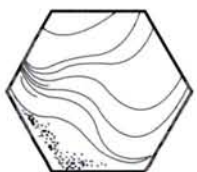

Hilly terrain is significantly higher than the surrounding terrain. The light lines in these hexes show slopes, which are more difficult to cross than Clear terrain because of the changes in elevation. Hills can contain clear, rough, wooded, or paved terrain

and buildings. Ground hexes that are not on a hill are at Level 0.

Elevation levels for each hill appear on the mapsheet. Level 1 is 6 meters high (waist-high on a BattleMech); a BattleMech standing behind a Level 1 hill may be partially hidden, and a vehicle is completely hidden. Elevation Level 2 terrain is 12 meters high (the same height as a BattleMech); a BattleMech standing behind Level 2 terrain is completely hidden. Level 3 terrain is 18 meters high, and so on.

## WATER

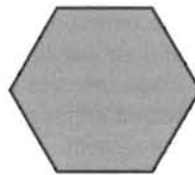

Hexes designated as water terrain are covered by streams, rivers, swamps, ponds, or lakes. A Water hex is defined by depth levels, which correspond to the elevation levels of hills. Depth 0 water is very shallow, no more than ankle-deep on a BattleMech, and represents terrain such as streams, swamps, or shallow ponds. Depth 1 water is 6 meters deep, or 1 level below ground level (about waist-high on a BattleMech). Depth 1 water is more difficult to cross than shallow water or Clear terrain and is found in rivers, ponds, and along lake shores. Depth 2 water is 12 meters deep, deep enough to just cover a BattleMech. Depth 2 water is much more difficult to cross than shallow water or Clear terrain. Depth 3 water is 18 meters deep, and so on.

Even when a shallow stream fills only part of a hex, that entire hex is considered a Water hex.

## BRIDGES



A Bridge hex may span a Water hex. Units moving along a road may use a bridge and so ignore the normal terrain restrictions and movement penalties they would suffer while moving elsewhere in a Water hex. If the bridge is not strong enough to support the weight of the crossing unit, it will collapse.

## LIGHT WOODS



Light woods terrain is covered with sparse trees of up to 12 meters in height. BattleMechs cannot cross this terrain as easily as Clear terrain. Unless the wood is relatively large (at least 3 hexes across), units may have line of sight through light woods. When light woods block line of sight, they do so for 2 elevation levels above their terrain.

## HEAVY WOODS



Heavily wooded terrain is covered thickly with 12-meter-tall trees, making movement very difficult through these areas. As in nature, heavy woods often thin out to light woods along their borders. Units cannot see through heavy woods. Also as with light woods, heavy woods block line of sight for 2 levels above their terrain.

WOLFNET ARCHIVE FILE:  
02335-AHG-23/34/7

From an interview with Callia Monar, author of *Fire In The Heavens: The History Of War In The Inner Sphere* (ComStar Press, 3056).

INTERVIEWER: In your book, you state that humans seem to prefer war to peace. Why do you think so?

MONAR: One simple reason: power. As a race, we crave it. The fall of the Star League and the Succession Wars that followed are a textbook example. When General Aleksandr Kerensky led the Star League Army out of the Inner Sphere in 2784, he left behind a power vacuum. The House Lords rushed to fill it, and that jockeying for power has kept the Successor States at each other's throats for the past three centuries.

INTERVIEWER: Was there any motivation for the Succession Wars aside from the hunger for power?

MONAR: On the part of individuals, perhaps. Collectively, no. Ever wonder why every Successor State ignored the Ares Conventions throughout the first two Succession Wars? Ever since 2412, the Ares Conventions had set out the rules of honorable warfare as an ideal to strive for, if nothing else. But the Successor States' power grab destroyed those standards, along with virtually everything else. By the time the Second Succession War ended, human technology had degenerated to a 21st-century level—practically back to the Stone Age.

INTERVIEWER: You differ from many historians in arguing that the Succession Wars are really one long conflict.

MONAR: Look at the dates. The First Succession War took place between 2786 and 2821, the Second Succession War lasted from 2830 until 2864, and the Third Succession War broke out in 2866. To this day, most of my colleagues can't agree on when the Third Succession War actually ended. . .they place it 'sometime in the early 31st century,' probably within a decade of the Fourth Succession War. The brief lulls between the Succession Wars are distinctions that let historians impose order on the chaos of our past. For people caught up in the conflict, it probably felt like one, long war with the odd breathing space between waves of slaughter.

*Continued on page 16*

## PAVEMENT



A Paved hex offers a fairly smooth and very hard surface. Paved hexes typically include roads, sidewalks, and landing fields made of asphalt, cement, or even cobblestone. Units that travel along Paved hexes containing roads ignore the slowing effects of other terrain indicated in the hex, and this terrain may increase the speed of ground vehicles. Running BattleMechs and vehicles moving at flank speed may skid on Paved hexes.

## COUNTERS

Certain features of terrain such as buildings, rubble, fire, and smoke can be represented on the map by counters made of cardboard or paper. Though buildings and similar features may be printed on the mapsheet, using counters to represent these features allows the players to decide their locations before the game begins, based either on the requirements of the scenario being played or on mutual player agreement.

### LIGHT BUILDINGS

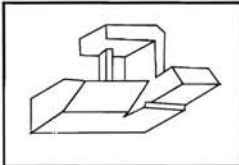

Light buildings generally represent small wooden or sheet-metal structures through which most BattleMechs can walk with little or no trouble. No BattleMech can land on any Light building, because the structure will not bear a 'Mech's weight. When determining line of sight, add the elevation of a Light building to the level of the underlying terrain.

### MEDIUM BUILDINGS

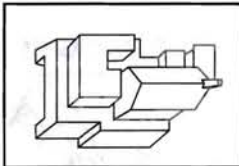

Constructed from stone, heavy wood, and metal, Medium buildings represent light industrial structures that offer more substance than Light buildings. Their heavier construction materials mean they can take more damage than Light buildings before being reduced to rubble. Up to 40-ton BattleMechs can land on some Medium buildings without collapsing the structure. When determining line of sight, add the elevation of a Medium building to the level of the underlying terrain.

### HEAVY BUILDINGS

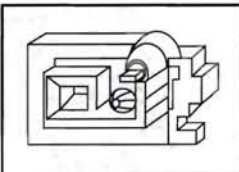

Usually part of industrial complexes, Heavy buildings are constructed of reinforced concrete, built to bear very heavy loads. All but the heaviest BattleMechs can land on Heavy buildings without collapsing the structure. When determining line of sight, add the elevation level of a Heavy building to the level of the underlying terrain.

### HARDENED BUILDINGS

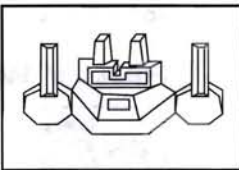

The builders intentionally strengthen Hardened buildings to withstand combat. Of all types of buildings, hardened structures can bear the most weight and sustain the most damage before being reduced to rubble. When determining line of sight, add the elevation level of a Hardened building to the level of the underlying terrain.

# COMPONENTS



## RUBBLE

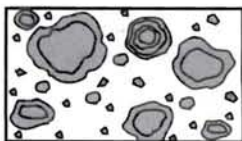

Weapons fire, fire damage, and physical damage inflicted by BattleMechs can reduce any building to rubble. A Rubble hex is difficult to move through and offers limited protection and cover from weapons fire. Rubble has no elevation level.

## FIRE



If fire is present on the map, each hex in flames must have a fire counter in it. These counters are only used if the rules for **Fire**, p. 84, are in effect.

## SMOKE



Fire also generates smoke, and these counters represent those hexes obscured by smoke.

## DICE

**BattleTech** requires players to use two six-sided dice, preferably of two different colors. If the player must roll one die, the game shorthands this as 1D6. The abbreviation 2D6 means the player rolls both dice. The rules will indicate whether the dice are rolled together to obtain a single number or separately.

## PLAYING THE GAME



This section provides the sequence of play for **BattleTech** and discusses the importance of rules for playing MechWarriors in **BattleTech**.

To begin a game, the players lay out the **BattleTech** mapsheets on a table or on the floor in a way agreed to by all players, or, if using a FASA scenario pack, according to the **Game Set-Up** of the scenario to be played. This step may include placing a number of buildings of varying height and type on the mapsheets. Next, the players fill out record sheets for each of their units involved in the battle. The BattleMech and vehicle descriptions required to fill out unit record sheets appear at the back of this book (see **Technical Readout**, pp. 125-132). Additional descriptions can be found in any of the **BattleTech Technical Readouts**, or completed record sheets can be copied from any of the **BattleTech Record Sheets** books. If all players agree, units may be created using the **Construction** rules, pp. 99-109. If the players decide to use OmniMechs, they may customize their weapons and equipment load. (See **Outfitting An OmniMech**, p. 106.)

### SEQUENCE OF PLAY

A **BattleTech** game consists of a series of turns. Each turn represents 10 seconds of game time. During each turn, all units on the map have an opportunity to move and fire their weapons. A turn consists of several smaller segments of time, called phases. During each phase, players will take one specific type of action, such as movement or combat.

The players execute the phases of every turn in a specific order. Specific actions, movement, effects of damage, and so on are fully explained in separate sections later in this book. Each turn includes the following phases, in the following order:

Initiative Phase  
Movement Phase  
Reaction Phase  
Weapon Attack Phase  
Physical Attack Phase  
Heat Phase  
End Phase

#### INITIATIVE PHASE

1. One player from each side rolls 2D6 (both dice) and adds the results together to determine his team's Initiative. The team with the higher result has the Initiative throughout the turn. Ties are rerolled.

#### MOVEMENT PHASE

2. The team that lost the Initiative chooses one unit and moves it first.

3. The team that won the Initiative moves one unit. Movement alternates between sides until all units have been moved. If, prior to any pair of movements, one team has twice as many units left to move as the other team, the team with twice as many moves two units rather than one. If one team has three times as many units, it moves *three each time*, and

# PLAYING THE GAME

so on. This means that the team that won the Initiative moves at least one of its units last. A player may designate a movement for any unit that has not been destroyed, even if the move is to simply stand (or lie) immobile.

## REACTION PHASE

4. The team that won the Initiative twists the torso of one of its BattleMechs one hexside either way, or rotates the turret on one of its vehicles, or declares for one of its units that it will not twist or rotate this turn.

5. The team that lost the Initiative twists the torso of one of its BattleMechs one hexside either way, or rotates the turret on one of its vehicles, or declares for one of its units that it will not twist or rotate this turn. Reaction twists/rotations alternate until all BattleMechs and vehicles have reacted or declared that they will not react. As with movement, if, prior to any pair of torso twists (turret rotations), one team has twice as many units left to twist or rotate as the other team, that team reacts with two units rather than just one. If one team has three times as many units, it reacts with three each time, and so on. The team that lost the Initiative twists or rotates last. A player may designate a reaction for any BattleMech or vehicle that has not been destroyed. The Reaction Phase does not apply to infantry.

## ◆ WEAPON ATTACK PHASE

6. The team that lost the Initiative chooses a unit to declare fire first. The player controlling that unit declares any attacks he plans to make using his unit's weapons, specifying which weapons he will fire and at what target(s). If a weapon uses special ammo loads, such as LB-X cluster munitions, the specific type of ammo to be used must also be declared at this time.

7. The team that won the Initiative chooses a unit to declare fire next. The player controlling that unit declares any attacks he plans to make using that unit's weapons. The act of declaring attacks alternates between players until all fire has been declared. If, prior to any pair of declarations, one team has twice as many units left to declare as the other team, that team declares two units, rather than just one. If one team has three times as many units, it declares three each time, and so on. The team that won the Initiative declares the last attack.

8. Weapons fire is resolved one unit at a time. Because all combat fire is considered to take place simultaneously, the order in which it is resolved does not matter, though all weapons attacks by one unit should be resolved before those of the next unit in order for the players to more easily track which weapons have fired.

9. Damage from weapons attacks takes effect. Players record damage as attacks are resolved, but this damage does not affect any unit until after *all* weapons attacks have been resolved. At that point, all damage takes effect immediately and players must make any Piloting Skill Rolls required due to the effects of weapons attacks. Note that damage taken by a unit during the Weapon Attack Phase takes effect before the start of the same turn's Physical Attack Phase.

## PHYSICAL ATTACK PHASE

10. Repeat Steps 6 through 9 for physical attacks, with all damage from these attacks taking effect before the Heat Phase.

## HEAT PHASE

11. Players adjust their BattleMechs' Heat Scale to reflect any heat built up or lost during the turn. Resolve any temporary or permanent damage caused by excessive internal heat at this time. Note that vehicles and infantry do not keep track of heat.

## ◆ END PHASE

12. Players whose MechWarriors lost consciousness in a previous turn now make a dice roll to see if the pilot regained consciousness during this turn.

13. Players execute any miscellaneous actions remaining in the turn, such as determining if any fires now on the mapsheet spread to other hexes. The specific rules for such actions will state whether or not they take place during the End Phase.

14. Repeat Steps 1 through 13 until one team meets its victory conditions. Normally, the team with the last surviving unit left on the board wins the scenario. If the last units from each team are destroyed simultaneously, the game is a draw. The players may set other victory conditions by mutual agreement before play begins or by using the **Victory Conditions** given for each scenario in the FASA scenario pack being played.

## MECHWARRIORS

The human soldiers who pilot BattleMechs are called MechWarriors. Their skills play an important role in keeping a BattleMech moving and fighting effectively in combat. A BattleMech will be knocked out of action if its MechWarrior is killed or seriously injured, even if the BattleMech suffers only minimal damage.

## MECHWARRIOR SKILLS

MechWarriors use two important skills in combat, Piloting and Gunnery. Inner Sphere MechWarriors of average skill have a Piloting Skill level of 5 and a Gunnery Skill level of 4. Clan MechWarriors of average skill have a Piloting Skill level of 4 and a Gunnery Skill level of 3.

A MechWarrior's Piloting Skill helps determine the outcome when a MechWarrior attempts to avoid falling, and to minimize damage when a BattleMech does fall down, as discussed in **Piloting Skill Rolls** (see **Movement**, p. 24). A MechWarrior's Gunnery Skill helps determine how easy or difficult it is to make a successful shot with the BattleMech's weapons, as discussed in **Firing Weapons** (see **Combat**, p. 33).

## Making Piloting Skill Rolls

When a BattleMech or vehicle attempts a potentially dangerous maneuver, or when the pilot might lose control of the unit for some other reason, the pilot must make a Piloting Skill

*Continued from page 12*

INTERVIEWER: Why didn't the Successor States stop in 2864? Why start another war just two years later?

MONAR: By 2866, entire generations had grown up who had never known peace. That's one of the reasons why the third war lasted so long. People had accepted war as the natural state of things. Also, the destruction of the first two Succession Wars reduced the fighting to raids and skirmishes. It takes a lot more small battles to achieve a decisive win over your enemy.

Ironically, the Third Succession War revived a version of the Ares Conventions. The need to preserve the ability to make war forced the Successor States to limit warfare. By unspoken agreement, vital technologies such as JumpShips that we'd lost the ability to make became off-limits as targets. But nobody thought of just ending the fighting.

INTERVIEWER: How did the Fourth Succession War differ from the previous three?

MONAR: The same need for power drove it. But the event that sparked it—the marriage in 3028 of Hanse Davion to Melissa Steiner—was the first real alliance by two Successor States against the remaining three. The Fourth Succession War was also by far the most decisive; almost half the Capellan Confederation fell before the Federated Suns-Lyran Commonwealth war machine. More borders changed between 3028 and 3030 than in the other three Succession Wars combined.

INTERVIEWER: Some people claim that if it weren't for the Clan invasion, the Successor States would have made peace because we're all tired of fighting. Do you think that's true?

MONAR: Just look around you. Do you think it's true?



Roll. (See **Piloting Skill Rolls in Movement**, p. 24.) The player adds the appropriate modifiers to his pilot's Piloting Skill level. The resulting number is the Piloting Skill Roll target number. Then the player rolls 2D6. If the result is equal to or greater than the modified Piloting Skill level, the action is successful and the unit suffers no adverse effects from the situation.

### ◆ Gunnery Skill Rating

A MechWarrior's base to-hit number is equal to his Gunnery Skill level. When modified for range, terrain, and other factors, this number becomes the modified to-hit number (see **Firing Weapons**, p. 33). A player whose unit fires a weapon must roll a dice roll result equal to or greater than the modified to-hit number in order to hit the target. As a result, the lower the Gunnery Skill level, the more likely the MechWarrior will be to hit his target.

### Varying Skill Levels

Rather than giving their MechWarriors the standard Piloting and Gunnery Skill levels, players can roll randomly at the beginning of the game to assign a Piloting and Gunnery Skill level to every MechWarrior (and vehicular combatant). This random generation usually produces an interesting mix of green and seasoned fighters. To use the Random MechWarrior Skills Table, the player rolls 1D6 to determine the MechWarrior's Piloting Skill level, and again to determine his Gunnery Skill level. If the player is playing a Clan MechWarrior, add 2 to the result of each of the die rolls before consulting the table.

**RANDOM MECHWARRIOR SKILLS TABLE**

Die Roll (1D6)	Piloting Skill	Die Roll (1D6)	Gunnery Skill
1	6	1	4
2	6	2	4
3	5	3	4
4	5	4	4
5	4	5	3
6	4	6	3
7-8	3	7-8	2

# PLAYING THE GAME

## SKILL IMPROVEMENT

Players may want to use the MechWarriors they create in future scenarios or in **BattleTech** campaign games—assuming, of course, that the warrior survives the current battle. In this case, players should keep track of the number of enemy BattleMechs destroyed by each surviving MechWarrior. For every 4 BattleMechs he destroys, the MechWarrior can reduce his Gunnery Skill or Piloting Skill by 1, though Gunnery and Piloting Skill levels can never be less than 0.

**MechWarrior, Second Edition**, the roleplaying game for the **BattleTech** universe, offers a more advanced system for Piloting, Gunnery, and other skills that can be used in place of these rules.

## DAMAGING A MECHWARRIOR

Three types of damage to a BattleMech can also damage the MechWarrior inside: head hits, falling, and internal ammo explosions. In addition, excessive heat build-up can result in damage to the MechWarrior if the BattleMech's life support system takes damage.

### Damage from Head Hits

The MechWarrior takes 1 point of damage (1 hit) whenever the BattleMech's head is hit, even if the hit does not penetrate the 'Mech's armor.

### ◆ Damage from Falling

If the BattleMech falls, the MechWarrior must make a Piloting Skill Roll. If he fails the roll, the pilot takes 1 point of damage.

### Damage from Ammo Explosions

An internal ammunition explosion causes 2 points of damage (2 hits) to the MechWarrior as a result of the electric shock he receives through his neurohelmet.

### Damage from Excess Heat

When the life support systems have taken a critical hit, the MechWarrior suffers 1 point of damage every turn that the BattleMech's internal heat is 15 or higher on the Heat Scale at the end of the Heat Phase. Every turn that the heat is 26 or higher causes 2 points of damage to the MechWarrior.

## CONSCIOUSNESS ROLLS

A MechWarrior can take 5 points of damage (5 hits) before dying from his injuries, but he may be knocked unconscious long before taking that much damage. Every time the MechWarrior takes damage, the player must immediately roll 2D6 and consult the MechWarrior Consciousness Table to determine if the MechWarrior remains conscious.

If the die roll result is equal to or greater than the consciousness number, the MechWarrior remains conscious. If the result is less than the consciousness number, the MechWarrior is knocked unconscious. The BattleMech becomes an immobile target, unable to move or fire. Any Piloting Skill Rolls that the

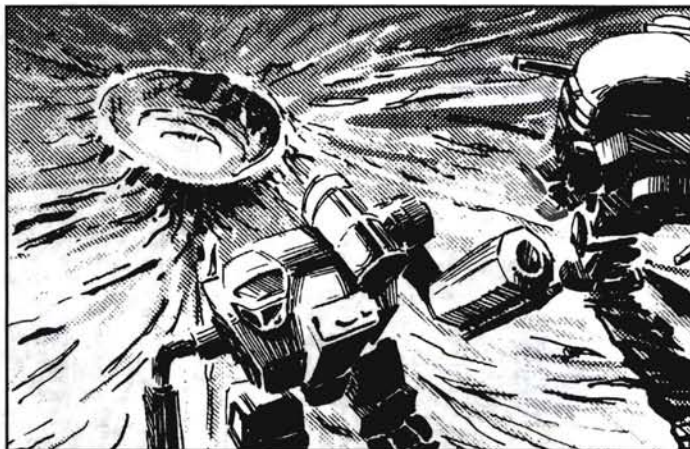

BattleMech must make while the pilot is unconscious automatically fail.

During the End Phase of each turn after the turn in which the MechWarrior loses consciousness, the player rolls 2D6 again. If the result is equal to or greater than the consciousness number for the MechWarrior's current level of damage, the MechWarrior regains consciousness. The player need not roll again to determine consciousness until the MechWarrior takes new damage. Of course, if the MechWarrior takes 6 hits, he is dead and never regains consciousness.

### MECHWARRIOR CONSCIOUSNESS TABLE

Total Consciousness Damage Points	Number
1	3
2	5
3	7
4	10
5	11
6	Dead

*In Turn 3, an Archer's head takes a hit from an attack with a medium laser. Though the laser does not penetrate the head's protective armor, the Archer's pilot takes 1 point of damage. He took 2 points of damage in previous attacks, and so now has a total of 3 hits. The player consults the MechWarrior Consciousness Table and rolls a 6, 1 point less than his pilot needed to remain conscious. The Archer will not be able to move or fire during Turn 4. In the End Phase of Turn 4, the player rolls 2D6 again. If he rolls a 7 or higher, the MechWarrior regains consciousness, and his BattleMech will be able to move and fire during Turn 5.*

## MOVEMENT

from entering that terrain. A unit that enters a hex under these conditions is considered to have run for the purpose of determining combat modifiers.

It costs a fallen BattleMech 2 MP to attempt to stand up. A fallen BattleMech may only attempt to stand up during the Movement Phase, but it may make multiple attempts as long as it has sufficient MP remaining. A fallen BattleMech with only 1 MP available at the beginning of its turn may make one attempt to stand using the exception noted in the previous paragraph. A fallen BattleMech cannot crawl into another hex, but it may change its facing in the hex it occupies. Once a fallen BattleMech regains its feet, any remaining MP may be used to move out of the hex in the same Movement Phase.

Certain vehicles and infantry units may not enter certain types of terrain. These movement restrictions appear on the Movement Cost Table.

### MOVEMENT DIRECTION

A BattleMech or vehicle can move forward into the hex it is facing or backward into the hex directly to its rear. It cannot move into any other hex unless it first changes its facing. To change its facing, the unit turns until the hex it wants to enter is directly to its front or rear. Then the unit may enter the hex. The diagram below shows the two hexes that a BattleMech or vehicle may enter without changing its facing.

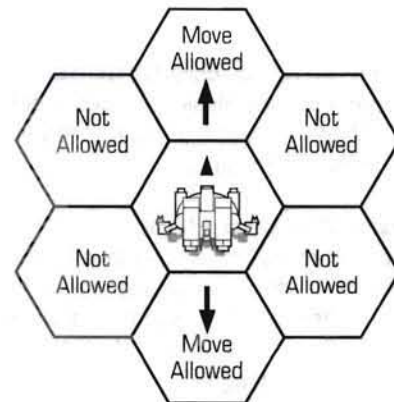

Because infantry units have no facing, they may enter any of the six hexes surrounding the hex they occupy, subject to terrain restrictions.

During the course of its movement, a BattleMech or vehicle can move forward and backward and change direction in any manner the player chooses. However, a BattleMech may not run backward, nor may a vehicle move at flank speed backward. Units moving backward may not change elevation levels.

While moving forward, a BattleMech may change elevation or depth by 1 or 2 levels per hex. (This rule does not apply to a jumping BattleMech. See **Jumping**, p. 20.) Ground vehicles and infantry may only change 1 elevation level per hex.

**BattleTech** units change their position and location on the mapsheet by performing any one of several movements or movement actions. During the Movement Phase of each turn, each player must choose one mode of movement (walking, running, or jumping for BattleMechs; cruising or flank speed for vehicles) that his unit will use during that turn. A unit may not combine movement modes during a turn.

When it is his turn to move a unit, the player must announce what movement mode he is using and how many Movement Points he has to spend on that movement. Within the limits of the rules, the player always chooses how a unit moves.

### MOVEMENT COSTS

A unit must spend at least 1 Movement Point (MP) to move 1 hex. If the hex the unit is entering is anything but Clear terrain, this cost usually increases, as shown in the Movement Cost Table, p. 19. Vehicles and infantry cannot enter some types of terrain, and for some terrain a player must make a successful Piloting Skill Roll for a BattleMech to remain standing once it enters that terrain. Such restrictions are described in the sections discussing the terrain to which they apply.

A unit must possess sufficient MP to pay the cost of entering each new hex. However, a unit can always move forward 1 hex, regardless of the terrain cost, under the following conditions: the unit enters only one hex that turn, the unit has at least 1 MP to spend (i.e., is mobile), and the unit is not prohibited

# MOVEMENT

## MOVEMENT COST TABLE

Terrain Type/ Activity	MP Cost Per Hex	Prohibited Units
Clear	1	Naval
Road/Paved/Bridge	1 <sup>3</sup>	Naval
Rough	2	Wheeled, Naval
Light Woods	2	Wheeled, Hover, Naval
Heavy Woods	3	Ground, Naval
Water		
Depth 0	1	Naval
Depth 1	2 <sup>1</sup>	Infantry, Ground <sup>4</sup>
Depth 2+	4 <sup>1</sup>	Infantry, Ground <sup>4</sup>
Elevation/Depth Change (up or down)	+1/level (Mechs, VTOL, Subs) +2/level (Infantry, Ground)	
Rubble	2 <sup>1</sup>	Wheeled, Naval
Light Building	2 <sup>2</sup>	Naval
Medium Building	3 <sup>2</sup>	Naval
Heavy Building	4 <sup>2</sup>	Naval
Hardened Building	5 <sup>2</sup>	Naval
Other Activities		
Facing Change	1/hexside <sup>5</sup>	
Dropping to the Ground	1	
Standing Up	2/attempt	

<sup>1</sup>Piloting Skill Roll required to prevent falling.

<sup>2</sup>Piloting Skill Roll required to prevent damage; infantry pay only 1 MP to enter or leave any building.

<sup>3</sup>If traveling along road; otherwise cost of underlying terrain.

<sup>4</sup>Hovercraft may enter all water hexes.

<sup>5</sup>No cost for infantry.

In the diagram, the BattleMech in Hex A has 4 MP (walking) or 6 MP (running). The player declares that the BattleMech will walk this turn. It will cost all 4 of the BattleMech's available MP to walk straight ahead into Hex B (1 MP) and then forward again into the heavy woods in Hex C (3 MP). It would cost all 4 MP for the BattleMech to move into Hex B (1 MP), then change its facing (1 MP) and move into the light woods in Hex D (2 MP). Similarly, it would cost the BattleMech all 4 MP to move into Hex E; first forward into Hex B (1 MP), then changing facing one hex (1 MP), and then entering the Depth 1 Water hex (2 MP). Finally, if the player wanted to move his BattleMech from Hex A directly to Hex F, he would first have to change facing (1 MP), and then, after climbing 2 elevation levels (+2 MP), enter the Clear terrain (1 MP).

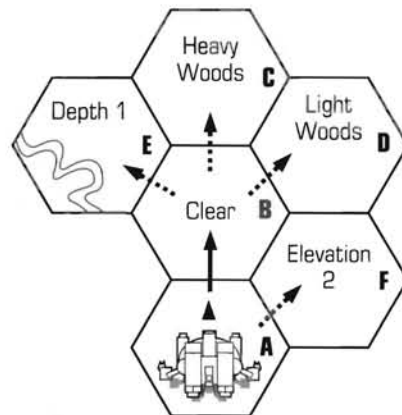

## MOVEMENT MODES

At the beginning of the Movement Phase and before moving, a player must select one of the following movement modes for his BattleMech or vehicle.

### STANDING STILL

If the player declares that the unit will stand still, the unit stays in the hex in which it started the turn. It does not move at all, not even to change facing. Standing still generates no heat, gives no penalty to weapons fire, and allows attackers to fire on the unit without target movement penalties.

There is no movement cost for standing still.

WOLFNET ARCHIVE FILE: 14267-VT3-31/4/5

Excerpts from Internal Bulletin No. 2378831r, 3050, and Internal Bulletin No. 2419921s, 3052 (ComStar Archives, Terra)

... since their appearance in the Periphery in 3049, the invaders have conquered every single world on which they have landed. They have taken large numbers of Periphery planets and would have overrun the Rasalhague Republic, but for the bravery of a Rasalhagian pilot. Wing Commander Tyra Miraborg rammed the invaders' flagship in a suicide run, killing their leader (who happened to be aboard). The invaders have halted their advance for the present, but no one knows for how long ... I believe the Draconis Combine is their next target. For all its fighting prowess, the DCMS will find it virtually impossible to beat back the invaders—they fight with BattleMechs more sophisticated and devastating than those we have preserved from the Star League era. Accompanying the BattleMechs are huge creatures in fearsome armor, only vaguely humanoid—these creatures can pull down an Inner Sphere BattleMech within seconds and strip it to its component parts.

From intercepted battlefield transmissions, we have learned that the invaders call themselves the Clans. I cannot tell if they are human or alien—given the ferocity of their fighting, I fear the latter ...

... incredible as it may seem, the Clans are human—the descendants of General Kerensky and the Star League Army, who vanished from the Inner Sphere nearly three hundred years ago. Every warrior among them, from the BattleMech pilots to the giant, armored infantrymen known as Elementals, is genetically bred for battle. The Precentor Martial should realize just how difficult our Com Guards will find it to defeat the Clans on the world of Tukayyid. Is it wise to stake the future of the Inner Sphere on a single battle? The fifteen-year truce, should we win, may give us the time we need to develop technology that can defeat the Clans—but if we lose, our homeworld of Terra will be forever lost to us. I cannot help but fear that even the Com Guards cannot stand against the Clans ...

## WALKING/CRUISING

If the player declares that the unit will walk/cruise, the unit may expend a number of MP up to its Walking (Cruising) MP rating. Walking creates 1 point of heat for BattleMechs.

A walking or cruising unit suffers a small penalty to its to-hit number when firing weapons. As a moving target, a walking unit is also harder to hit. These combat effects appear on the appropriate To-Hit Modifier Tables in the **Combat** section, p. 30, and are explained in that section.

## ◆ RUNNING/FLANK SPEED

A unit can move further in a turn when running (or moving at flank speed, for vehicles) than it can walking. The player may spend up to the Running MP rating of the unit each turn. Running units pay the same movement costs as do walking units. However, no unit can move backward while running, nor can it enter Water hexes of Depth 1 or deeper.

Running creates more heat for a BattleMech (2 Heat Points per turn) than walking does. A unit that is running (moving at flank speed) suffers penalties to its to-hit number when firing weapons, but its speed also makes the unit a more difficult target to hit. These effects are explained in the **Combat** section, p. 30. In addition, a running BattleMech or a ground vehicle moving at flank speed on a paved surface may skid (see **Skidding**, p. 23).

Certain damage to a unit may reduce its Walking/Cruising MP rating. When such damage occurs, the unit's running/flank speed must be recalculated. A unit's Running/Flank MP rating is always equal to its Walking/Cruising MP times 1.5, rounding up.

## ◆ JUMPING

Not all units can jump. Only some BattleMechs, jump infantry, and battle-armored troops are jump-capable. A jump-capable unit may move into any hex within its jump range. The terrain type in the landing hex does not matter, nor does the BattleMech's original facing. A jumping BattleMech will land facing whatever direction the player chooses.

A BattleMech cannot be constructed with Jumping MP greater than its Walking MP. A jump-capable unit may not jump higher, in levels, than its Jumping MP. Jumping generates a great deal of heat; 1 Heat Point for every hex jumped with a minimum cost of 3 Heat Points. Even if a BattleMech only jumps 1 hex, it builds up 3 Heat Points for that jump. Jumping also makes it harder to fire weapons accurately, but a jumping BattleMech makes a more difficult target than a running or walking BattleMech. These effects are explained in the **Combat** section, p. 30.

When a unit jumps, it can move 1 hex in any direction for every available Jumping MP. It can jump over and into any hex, regardless of terrain type or elevation difference (within the elevation restriction given above). The path a jumping unit travels is always the shortest one possible between the starting and ending hexes. If this path crosses an elevation higher than the unit's Jumping MP, then the unit cannot make the jump. If there is more than one possible path between the unit and its goal hex, the player may declare which path his unit takes.

Because it requires the unit to fire its jump jets, jumping may not be combined with any other movement mode. The process of firing the jump jets, lifting off, and landing requires a full Movement Phase. BattleMechs must be standing at the start of the turn in order to jump.

Jump jets cannot be fired while submerged in water, and so a 'Mech standing in Depth 2 or deeper water cannot jump. If a 'Mech is standing in Depth 1 water, it may not fire jump jets located in its legs, but it may use any jets located in the torso, each one providing 1 Jumping MP. For example, a 'Mech with a Jumping MP of 5 that has one jump jet in each leg and each torso location may only use 3 MP when jumping out of Depth 1 water.

# MOVEMENT

BattleMechs that jump with damaged leg actuators or gyros must make a Piloting Skill Roll to avoid falling when they land.

The BattleMech in Hex A of the following diagram has a Jumping MP of 6. The BattleMech jumps to Hex B, 4 hexes away. Because the BattleMech is using jump movement, it spends only 1 MP for every hex that it moves, ignoring all terrain costs for the hexes it passes over and for the hex in which it lands. As it lands, the player can face the BattleMech in any direction he chooses, at no extra cost. To reach Hex B by walking or running, the BattleMech would have had to spend at least 11 MP.

The BattleMech could have jumped into Hex B by at least three paths, as indicated on the diagram. If the hill had an Elevation Level of 7, the BattleMech could not have used path 1 (because the 'Mech has a Jumping MP rating of 6), but the player still could have chosen path 2 or 3.

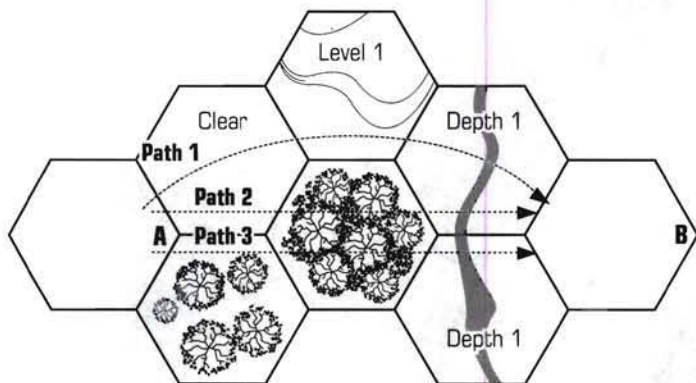

## FACING

Every hex on the map has six edges, called hexsides. In **BattleTech**, every BattleMech and vehicle must be oriented to face one of those six hexsides. A BattleMech is considered to be facing the way its feet are pointing. A vehicle is considered to be facing in the direction of its Front side. A unit's facing affects both movement (see below) and combat (see **Combat**, p. 30), and can only be changed during the Movement Phase.

Units not clearly facing a hexside can be realigned to one of the two possible hexsides by the opposing player.

Infantry units have no facing.

## FACING CHANGE

Every hexside by which a unit changes its facing costs 1 MP. A 180-degree turn would cost a BattleMech or vehicle 3 MP.

A player wants to move the BattleMech in the diagram from Hex A to Hex B. However, the

BattleMech is currently facing Hex C, and so cannot legally move to Hex B. If the BattleMech changes its facing, as shown in Figure 2, the BattleMech can now legally move into Hex B. This facing change costs 1 MP.

If the player wanted to move the BattleMech into Hex D (without moving backward), the BattleMech would have to make a two-hexside facing change, at a cost of 2 MP.

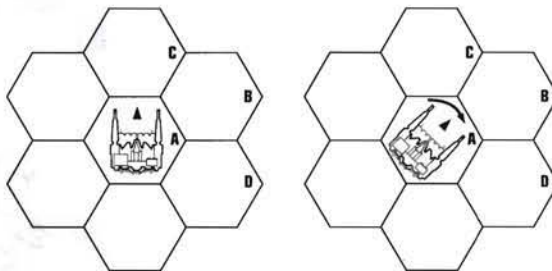

## DROPPING TO THE GROUND

A player may choose to have his BattleMech drop to the ground during combat. Usually, he will do this at the end of movement to hide or to make attacks against the BattleMech more difficult.

This action creates no additional heat, causes no falling damage, and costs 1 MP. The BattleMech drops with the same facing it had while standing, and automatically falls face down, as with an unintentional fall (see **Falling**, p. 26).

## ◆ ROAD/PAVEMENT MOVEMENT

All units traveling on roads pay only 1 MP per hex regardless of the hex's underlying terrain except for elevation change. A unit is considered to be traveling on a road if it moves from one hex to the next on that road.

Units may move through prohibited terrain while traveling on a road, but they must begin and end their movement through such terrain on the road and remain on that road while traveling through the terrain.

In addition, ground vehicles may receive a movement bonus of 1 additional hex for moving on a road. To move an extra hex, the unit must begin its turn on a Paved hex containing a road and continue to travel along the road for the entire Movement Phase.

## BRIDGE MOVEMENT

Roads that cross a Water hex are considered bridges. Bridges are classified as Light, Medium, or Heavy, in the same manner as buildings, and have the same range of Construction Factors (CF) as Light, Medium, and Heavy buildings (see **Buildings**, p. 56). Thus, only infantry units and vehicles that weigh 15 tons or less may use Light Bridges. Medium Bridges

WOLFNET ARCHIVE FILE: 55684-PK9-43/1/6

From *Opening Gambit*, a novelization of the Clan Invasion's first battle in the Periphery region known as The Rock

Phelan Kell hit his comm button, opening a tight channel to Hound Leader. "Those 'Mechs took out that Panther far too easily. Dammit, large lasers can't do that kind of damage from nine hundred yards away! I don't like this, Jack. Keep Trey and Kat out of it. God save us, look what they're doing to the *Rifleman!*"

The two unknown, gray 'Mechs moved in on the last operational pirate machine, simultaneously firing short-range missile barrages. The missiles covered the trapped *Rifleman* with explosions. The blasts staggered the machine, opening cratered wounds in its armor that oozed melted metal. Sparks lanced from the barrels of the *Rifleman's* guns as one of the strange 'Mechs walked autocannon fire along them and into the *Rifleman's* right shoulder. The second mystery 'Mech raked a stream of autocannon shells across the *Rifleman's* belly. The projectiles ripped jagged scars in the 'Mech's armored flesh while fire from the other autocannon gnawed away at the *Rifleman's* already-mauled left shoulder. It sliced through the remaining armor and drive mechanisms with the ease of a razor carving flesh. The 'Mech's left arm lurched, then dropped toward the ground, only to be jerked to a halt by useless drive chains and belted links of autocannon ammo. Swinging slowly back and forth, the arm dangled like a hideous ornament.

Jack Tang spoke unsteadily over Phelan's comm. "Hound Deuce, I'm going to hail these guys. If I offer them salvage on these 'Mechs, maybe they'll give us Kenny to take back and collect our pay."

Fear boiled up from Phelan's gut. "Jack, don't. Get the hell out of here." He started running the *Wolfhound* forward. "Move it, Jack! They're up to something!"

"Get back here, Phelan! That's an order!" Anger rippled through Tang's voice. "Dammit, follow my orders just for once!"

"And let you die? No way. Move it, Jack! Jump out of there!"

# MOVEMENT

**SKID MODIFIER TABLE**

Hexes Moved	Piloting Skill Modifier
0-2	-1
3-4	0
5-7	+1
8-10	+2
11+	+4

usually support units weighing up to 40 tons, while Heavy Bridges can support units weighing up to 90 tons. Units that exceed these weights cannot move across the Water hex using the bridge. A unit weighing more than the bridge will support can declare that it intends to collapse the bridge. The unit must take normal falling damage from the collapse of the bridge.

For combat purposes, a bridge can be attacked like a building. When its CF is reduced to 0, the bridge has collapsed.

## ◆ SKIDDING

When a BattleMech or a ground vehicle is running (moving at flank speed) on a paved surface or road, the unit may slip and lose control. For a BattleMech that runs (or a ground vehicle that moves at flank speed) in a Paved hex after changing its facing, the player must make a Piloting Skill Roll modified by a factor based on the total number of hexes moved in the turn so far, using the Skid Modifier Table. If the die roll result equals or exceeds the unit's modified Piloting Skill, the running turn causes no effect. If the result is less than the modified Piloting Skill target, the BattleMech falls, suffering normal falling damage, or the ground vehicle loses control and goes into a skid.

A BattleMech or ground vehicle skids for a number of hexes equal to the number of hexes it has moved in the turn so far, continuing in the direction it was traveling before making the facing change that caused it to skid. If an obstacle (any terrain or building that is higher than the terrain the skidding unit currently occupies) or unit lies in the way, the unit crashes into it according to the charging rules (see **Charging**, p. 47). The crash is resolved immediately and, unlike normal charging attacks, can affect a unit that has not yet moved. Use the distance the unit moved before the skid to calculate damage. If the unit skids into a building, the building takes damage as from a charging attack. If the unit skids into an infantry unit, the infantry unit receives damage equal to the skidding unit's ton-

nage divided by 5, and the unit continues its skid. Skidding represents one of the few ways that units can inflict damage during the Movement Phase.

For every hex that a BattleMech skids, it suffers damage equal to one-half its normal falling damage, rounded up (see **Falling**, p. 26). Use the Front column of the BattleMech Hit Location Table, p. 39 in **Combat**, to determine the location of this damage. Vehicles moving at flank speed suffer the same effect in a skid, except that no damage occurs unless the vehicle hits something. Add +2 to the to-hit number for all weapons fire and physical attacks made against a skidding unit during the turn in which it skids.

Players need not make a Piloting Skill Roll when making a facing change while running on a paved surface or road. A Piloting Skill Roll is only required when a unit runs *after* making a facing change, as illustrated in the diagram and example.

*The Phoenix Hawk in Hex A wants to end its turn in Hex G. To spend the required 8 MP, this BattleMech must run. It runs to Hex C and makes a facing change toward Hex D. No Piloting Skill Roll is required. However, when the BattleMech moves to Hex D, still running, the player must make a Piloting Skill Roll because the BattleMech ran after making a facing change. So far, the BattleMech has moved 3 hexes, and so the modifier for the Piloting Skill Roll is 0. The player needs to roll a 5 or better to avoid skidding. The player rolls a 10, and the BattleMech continues to run toward Hex G.*

*The BattleMech makes another facing change in Hex E toward Hex F. In order to move safely from Hex E to Hex F, the player must make another Piloting Skill Roll, this time modified by +1 because the BattleMech has moved 5 hexes. The modified Piloting Skill Target Number is 6 (5 + 1). The player rolls a*

*5, which means the pilot failed to maintain control of the BattleMech, and his 'Mech skids down the F-L hex row. Because no obstructions block its path,*

*the BattleMech will skid for 5 hexes. The Phoenix Hawk suffers 5 points of*

*falling damage (45 tons divided by 10 is 4.5, rounded up to 5) and 3 points of damage per hex of the skid (1/2 falling damage of 5, rounded up) for a total of 20 (5 + 15). Needless to say, the Phoenix Hawk should have jumped.*

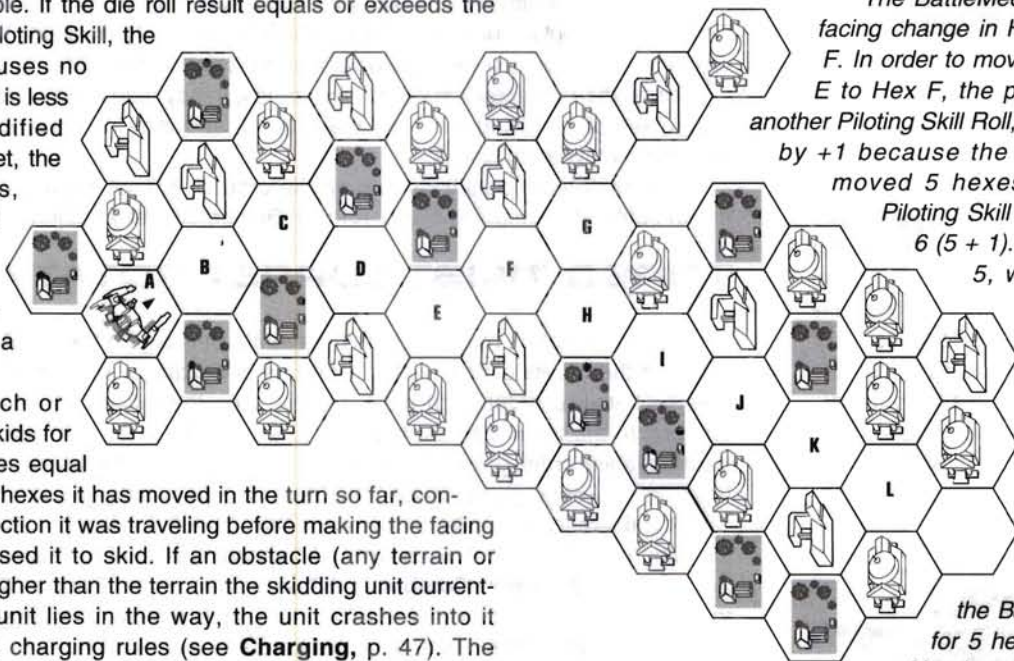

WOLFNET ARCHIVE FILE: 03552-EF9-32/6/3

Excerpted from *Manifest Destiny: Humanity's Star Empires*, by Misha Auburn (Commonwealth Press, 3054)

When the human race first reached the stars, five families gave their names to the dynasties—and empires—that came to shape the Inner Sphere. The Great Houses of Steiner, Davion, Kurita, Marik, and Liao founded the Lyran Commonwealth, the Federated Suns, the Draconis Combine, the Free Worlds League, and the Capellan Confederation. Fiercely proud of their different traditions and cultures, these nations have spent most of their mutual history in conflict.

Under the leadership of the Camerons of Terra centuries ago, the five star empires briefly became equal member-states of the Star League, humanity's noblest experiment in peaceful coexistence. Alas, as with so many alliances throughout human history, the Star League fell to treachery and its members succumbed to the evil of war. Calling themselves the Successor States in token of their hopes to succeed the Camerons as rulers of the Star League, the five realms warred with each other for three centuries, each determined to dominate the Inner Sphere. Even the first step toward peace, the recent union of the Federated Suns and the Lyran Commonwealth, occurred against the backdrop of a brutal war of conquest.

The long and bloody Succession Wars have left deep scars on all who fought and suffered through them; only the arrival of a powerful, common enemy put an end to them. The swift, brutal Clan invasion has forced the Inner Sphere's warring members to work together for survival, but the partnership is uneasy at best. Age-old hatreds do not die overnight, and the recent truce with the Clans has brought ancient fears and suspicions back to the forefront of Successor State relations.

## STACKING

During the Movement Phase, a unit may move through hexes occupied by other friendly units, but a unit may not move through a hex occupied by an enemy unit, nor may it end its movement in a hex that would violate the following "stacking" limits. At the end of the Movement Phase:

- Only one BattleMech (friendly or enemy) can occupy a hex.
- Up to two friendly vehicle and infantry units may occupy a single hex. These units can be in any combination, but only one of the units can be a BattleMech. A maximum of four units may occupy a hex at the end of the Movement Phase (two friendly units from each force) by ending their movement in that hex, but only one of the four units may be a BattleMech.
- These stacking rules do not apply to units in the same building on different levels. Within a building, apply these stacking limits to each level of the building.
- Infantry mounted on a vehicle and battle-armored troops riding on a BattleMech do not count against this stacking limit.

It is important to note that while only one BattleMech can occupy a hex, it does not actually take up the entire hex. A 30-meter-wide hex offers plenty of room for a 12-meter-tall 'Mech to move around and avoid fire, and still allows up to three non-'Mech units to share the hex. Simply put, a BattleMech tactically controls the hex it occupies but does not physically fill it.

## ◆ STANDING UP

The player may choose to have a BattleMech attempt to regain its feet after falling or dropping to the ground. Each attempt to stand creates 1 point of heat and costs 2 MP. A BattleMech may stand during the same turn that it fell, as long as it still has sufficient MP to make the attempt and it was not jumping that turn. BattleMechs may only attempt to stand during the Movement Phase.

For a fallen BattleMech to stand up, the player must make a successful Piloting Skill Roll. If the attempt is not successful, the BattleMech falls again, taking falling damage. The unit may make repeated attempts to stand as long as it has Movement Points available.

Once the BattleMech successfully stands, it may face in any direction (at no cost), regardless of its facing while on the ground, and may continue to move using any remaining Movement Points.

If a BattleMech begins its turn on the ground, it must declare whether it will walk or run before it attempts to stand. A fallen BattleMech may not jump.

## TORSO TWIST/TURRET ROTATION

At the end of all movement, the players can twist the torsos of their BattleMechs or rotate the turrets of any turreted vehicles or buildings. Torso twisting takes place in reverse Initiative order, with the team that won the Initiative twisting or rotating one unit before the team that lost Initiative twists or rotates one of their units. While standard Initiative order gives the team that won Initiative the advantage of moving last, this reversed order gives the team that lost the Initiative the advantage of twisting last.

A BattleMech can twist its torso one hexside (60 degrees) to the left or right of the direction in which its feet are pointing. This new alignment modifies a BattleMech's firing arc as described in **Combat**, p. 33, but for movement and hit location purposes, the BattleMech is still considered to be facing in its pre-twist direction.

Vehicles with turrets may align the turrets to any hexside. Rotating its turret modifies a vehicle's firing arc as described in **Combat**, p. 33.

## PILOTING SKILL ROLLS

Players must make Piloting Skill Rolls in order for their MechWarriors to avoid falling under the following conditions: whenever a MechWarrior attempts to move his



# MOVEMENT

BattleMech through exceptionally difficult terrain; his BattleMech receives 20 Damage Points or more in a single phase; certain components of his BattleMech are damaged; and to compensate for other, specific events.

Vehicle pilots make Piloting Skill Rolls only to avoid skids and to avoid taking damage when entering buildings.

## ◆ MAKING PILOTING SKILL ROLLS

The Piloting Skill Roll Table lists the events that require a player to make a Piloting Skill Roll for his BattleMech's MechWarrior. Each time one of these events occurs, the player

adds the following modifiers to his MechWarrior's Piloting Skill: any indicated modifiers for the event, plus additional modifiers from other events taking place in the same phase, including those listed under Additional Modifiers on the Piloting Skill Roll Table. The resulting number is the Modified Piloting Skill level. To make the Piloting Skill Roll, the player rolls 2D6.

If the result is equal to or greater than the Modified Piloting Skill, the BattleMech avoids falling. If the result is less than the Modified Piloting Skill, the BattleMech falls. If the BattleMech falls during the Movement Phase and has at least 2 MP remaining, it may attempt to regain its feet that turn.

## PILOTING SKILL ROLL TABLE

BattleMech's Situation	Modifier
Damage to BattleMech	
BattleMech takes 20+ Damage Points in one phase	+1
BattleMech reactor shuts down	+3 <sup>1</sup>
Leg/foot actuator destroyed	+1
Gyro hit	+3
Gyro destroyed	Automatic Fall
Leg destroyed	Automatic Fall
Physical Attacks on BattleMech	
BattleMech was kicked	0
BattleMech was pushed	0
BattleMech was charged/death from above attack	+2
Unit's Actions	
BattleMech missed kick	0
BattleMech charging	+2
BattleMech death from above attack	+4 <sup>2</sup>
BattleMech entering Depth 1 Water hex	-1
BattleMech entering Depth 2 Water hex	0
BattleMech entering Depth 3+ Water hex	+1
BattleMech attempting to stand	0
BattleMech entering Rubble hex	0
Unit entering/leaving Light Building hex	0 <sup>3</sup>
Unit entering/leaving Medium Building hex	+1 <sup>3</sup>
Unit entering/leaving Heavy Building hex	+2 <sup>3</sup>
Unit entering/leaving Hardened Building hex	+5 <sup>3</sup>
Unit Skids	See <b>Skidding</b> , p. 23
BattleMech jumping with damaged leg actuators	per Additional Modifiers, below
MechWarrior trying to avoid damage when his BattleMech is falling	+1/ level fallen

<sup>1</sup>Only during the turn that the reactor shuts down. If the MechWarrior must make a Piloting Skill Roll for a 'Mech with a shut-down reactor, the BattleMech automatically falls.

<sup>2</sup>Automatic fall if death from above attack is unsuccessful.

<sup>3</sup>To avoid damage only. Does not result in a fall if Piloting Skill Roll fails. See **Buildings**, p. 56

Additional Modifiers	Modifier
Per leg/foot actuator previously destroyed	+1
Per hip also/previously destroyed	+2
Gyro also/previously hit (automatic fall if 2 previous hits)	+3
Leg previously destroyed	+5 <sup>4</sup>

<sup>4</sup>Do not add modifiers for the destroyed hip and other damaged actuators in the leg.

# MOVEMENT

WOLFNET ARCHIVE FILE: 133478-1L7-32/4/0

## Partial transcript of Colonel Jaime Wolf's speech to the assembled House Lords on Outreach, 3051

WOLF: The Clans are descended from Aleksandr Kerensky and the Star League Army. They've spent 300 years perfecting warfare, and are the most formidable enemy you will ever face. Want to defeat them? Learn something of what shaped them. (SILENCE) The Clans arose from the ashes of a civil war that nearly destroyed the Star League Army. Aleksandr's son Nicholas led a group of loyalists away from the war-torn Clan planets to another world, where they formed a society based on a caste system with the Warrior caste on top.

To ensure that only the strongest and brightest became warriors, Nicholas established a breeding program. Today's Clan Warriors are genetically engineered for combat, conceived in test tubes and born in metal wombs. Most Clansmen find natural childbirth repugnant; they call the engineered warriors "trueborn" and the rest of us "freeborn," which they regard as a deadly insult. We "freebirths" are mostly confined to the lower castes, with only a few good enough to "test out" and join the Warrior caste.

The toughest warriors are the truebirths with two names. Clansmen don't have surnames at birth; they earn them through trial by combat, which only the finest fighters survive. These surnames, called "Bloodnames," were the names of Nicholas Kerensky's loyal followers. Having a Bloodname is one of the highest honors a Clan Warrior can possess.

Only Bloodnamed Warriors can become one of each Clan's two ruling Khans. Though a Grand Council made up of all the Khans from the seventeen Clans made the decision to invade, the ilKhan—the chief warlord, if you will—runs the show on the battlefield. Luckily for the Inner Sphere, the Clans' newly elected ilKhan is Ulric Kerensky, a Warden. That's one of the two political factions—Wardens and Crusaders. The Wardens believe that the Clans should protect the Inner Sphere from any outside threat; the Crusaders regard it as a corrupt realm to be conquered and purified so they can resurrect the Star League. ilKhan Ulric hopes to rein the Crusaders in by controlling the war effort as much as he can ...

Piloting Skill Rolls required because of movement (entering water, trying to stand up, entering rubble, avoiding falling damage, and so on) must be made immediately following the action. Multiple rolls may be required during the BattleMech's movement for a turn. For example, if a BattleMech is moving through 3 hexes of Depth 1 water, the player must make a Piloting Skill Roll when the BattleMech enters each of the three Water hexes.

All Piloting Skill Rolls required because of weapons attacks must be made at the end of the Weapon Attack Phase of the turn. Note that a BattleMech only makes one Piloting Skill Roll for taking 20+ Damage Points in a single phase, regardless of how many points of damage over 20 it takes. All weapons attacks are resolved before the players make any required Piloting Skill Rolls. BattleMechs that fall during the Movement Phase begin the turn's Physical Attack Phase in a prone position.

All Piloting Skill Rolls required because of physical attacks are made at the end of the Physical Attack Phase. Resolve all physical attacks before making any Piloting Skill Rolls.

*During the Weapon Attack Phase, a BattleMech whose MechWarrior has a Piloting Skill of 5 takes 40 points of damage and loses 2 leg actuators. The player makes one Piloting Skill Roll for taking 20 or more points of damage, and two more for losing 2 leg actuators. The modified Piloting Skill Target Number for each of the three rolls is 8 [5 (Piloting Skill) + 1 (20+ points of damage) + 1 (damaged leg actuator) + 1 (damaged leg actuator)].*

*During the Physical Attack Phase, the same BattleMech is kicked in the leg by two other BattleMechs, in the process losing another actuator and taking 23 more points of damage. The player must make four more Piloting Skill Rolls: two for being kicked twice, one for losing a leg actuator, and one for the 23 points of damage. The modified Piloting Skill Target Number for each of the four rolls is 9 [7 (existing actuator damage) + 1 (another damaged leg actuator) + 1 (20+ points of damage)].*

## FALLING

When a BattleMech falls, both the machine and its pilot may suffer damage. The amount of damage taken by the BattleMech depends on its weight and the distance it falls. Whether or not the MechWarrior suffers an injury depends on a Piloting Skill Roll.

### Determining Location after a Fall

To determine the location of a BattleMech after a fall, the players must use their judgment and the following guidelines to create a reasonable outcome. Location after a fall should be largely determined by the action that created the fall.

In general, when a BattleMech falls because of terrain (movement into or out of deep water, for example), the BattleMech will fall into the lower of the two hexes. If the fall occurs during the Movement Phase from other causes, the BattleMech falls in the hex it was entering. If a fall occurs because of weapons fire, a physical attack, or any other reason related to combat, the BattleMech falls in the hex it currently occupies.

If a BattleMech falls into a hex occupied by another BattleMech, the second BattleMech might also take damage, depending on how the BattleMech falls. If the BattleMech fell from a hex 2 or more elevation levels above the landing hex, use the **Accidental Falls from Above** rules, p. 51. If the BattleMech fell from a hex only 1 level higher, use the **Domino Effect** rules, p. 51. If a BattleMech falls in a hex occupied by infantry and/or vehicles, the BattleMech hits the ground, missing any non-BattleMech units.

To find the number of levels the BattleMech fell, subtract the terrain elevation level of the hex into which the BattleMech fell from the terrain elevation level of the hex from which it fell.

# MOVEMENT

## Facing after a Fall

When a BattleMech falls, it takes damage and its facing may change. This facing change determines the BattleMech Hit Location Table used when allocating damage from the fall.

To determine the unit's facing after the fall and the area of the BattleMech that takes damage from the fall, roll 1D6 and consult the Facing after a Fall Table.

**FACING AFTER A FALL TABLE**

Die Roll (1D6)	New Facing	Hit Location
1	Same Direction	Front
2	1 Hexside Right	Right Side
3	2 Hexsides Right	Right Side
4	Opposite Direction	Rear
5	2 Hexsides Left	Left Side
6	1 Hexside Left	Left Side

A fallen BattleMech lies prone and face down. BattleMechs that fall on their sides or rear automatically roll over to lie on their fronts. Rather than attempting to stand after a fall, a prone BattleMech may spend Movement Points to change its facing in the normal manner.

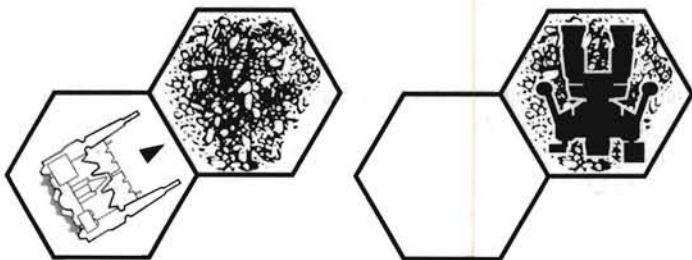

*The BattleMech in the diagram was entering a Rubble hex and failed its Piloting Skill Roll. The player rolls 1D6 with a result of 3 and consults the Facing After a Fall Table. The BattleMech is now facing 2 hexsides to the right (clockwise) of its original facing and takes the damage from the fall on its right side. The BattleMech is now prone and face down in the Rubble hex.*

## Falling Damage to a BattleMech

A BattleMech always takes damage from a fall equal to 1 point for every 10 tons that the BattleMech weighs (rounding up) times the number of levels plus 1 that the BattleMech fell. If it fell "uphill," the number of elevation levels it fell is 0. If it fell from land into a Water hex, treat the Water hex as a Level 0 hex and apply only half the resulting damage (rounding up).

Divide the damage into clusters of 5 points each: in other words, form as many 5-point groups as possible, assigning any remaining points to one smaller group, and determine a hit location for each cluster. For example, a BattleMech that suffers 33

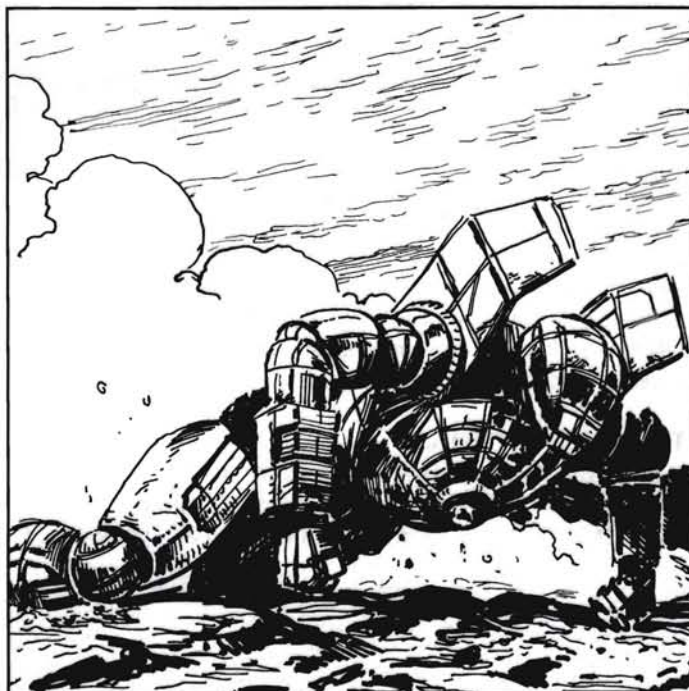

points of falling damage takes six clusters of 5-point hits and one 3-point hit. To determine the location of the damage, use the appropriate column of the BattleMech Hit Location Table, p. 39 in **Combat**, as specified by the Facing after a Fall Table.

If the fall occurs during the Movement Phase, resolve the damage as it happens. If the fall occurs during a Combat Phase, the damage from the fall occurs simultaneously with all other damage in that phase.

*An Archer in a Level 1 hex attempts to stand during the Movement Phase. The MechWarrior fails his Piloting Skill Roll and the BattleMech falls again into the same hex. The BattleMech fell from a Level 1 to a Level 1 hex (the same one) and so fell 0 levels. The player rolls a 1 on the Facing after a Fall Table and finds that the BattleMech landed on its face. It takes the falling damage on its Front. The Archer suffers 7 points of damage (70 tons divided by 10 is 7; the number of levels fallen plus 1 equals 1;  $7 \times 1 = 7$ ). These 7 points are divided into one cluster of 5 and one of 2. The player then uses the Front column of the BattleMech Hit Location Table to determine the location of the damage.*

## Falling Damage to the MechWarrior

To determine if the pilot took damage when the BattleMech fell, the player makes a second Piloting Skill Roll after every fall, adding 1 to the MechWarrior's Piloting Skill target for every level fallen. If the die roll result is equal to or greater than this modified Piloting Skill target, then the MechWarrior avoided taking any damage. If not, the MechWarrior takes 1 point of damage.

WOLFNET ARCHIVE FILE: 99213-TV5-22/0/4

From a promotional pamphlet distributed by Skobel MechWorks of Terra

## THE FIRST

In 2439, the introduction of a lethal new weapon revolutionized modern warfare forever. That weapon was the first BattleMech—the MCK-5S *Mackie*. Though the *Mackie* is primitive by today's standards, the machine represented the most advanced battlefield technology of its day. Now, 600 years later, Skobel MechWorks is proud to commemorate the birth of the *Mackie*, the ancestor of all modern BattleMechs.

## THE MODERN BATTLEMECH

The modern BattleMech is perhaps the most complex machine ever produced. Each 'Mech contains thousands of different components, far too many to explain here. But exploring the systems and the

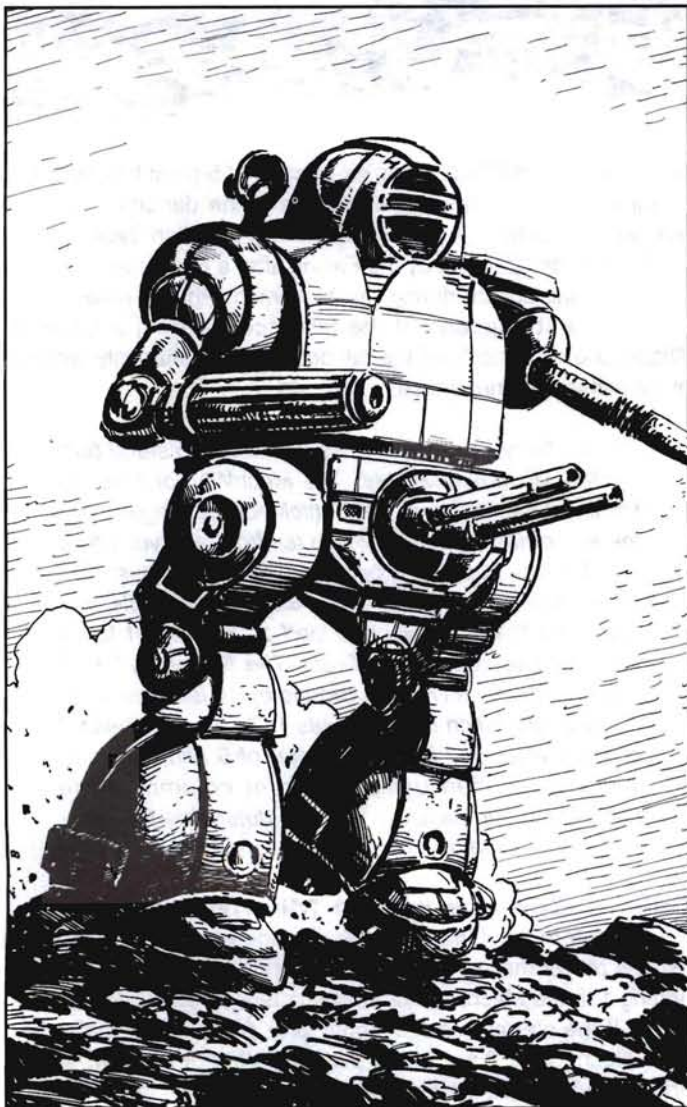

capabilities of BattleMechs is a great way to start getting to know these marvelous machines.

## Skeleton

Every BattleMech contains a "skeleton" made up of several dozen "bones." Each bone is a honeycombed, foamed-aluminum core wrapped with stressed silicon-carbide monofilament and protected by a rigid, titanium-steel shell. Each of these artificial bones has attachment points for the myomer "muscles" and servos that drive the BattleMech. The skeletal construction helps make BattleMechs less vulnerable and easier to repair than vehicles supported by stressed-skin shells.

## Muscles

Two different systems are used to drive BattleMechs and control their movements. Small, electrically driven actuators move a 'Mech's light weapons and sensor arrays. Bundles of polyacetylene fibers called myomers control a 'Mech's limbs and main weapons. Myomers contract when exposed to electrical current, much like human muscles. And if damaged in battle, technicians can replace the fiber bundles with new ones or "transplant" myomers from other parts of the 'Mech's skeleton. Transplanted myomer bundles cannot restore full function to a damaged limb, but they do provide limited mobility and strength.

## Armor and Weapons

Two separate layers of armor provide modern BattleMechs with protection against energy and projectile weapons. Usually, aligned-crystal steel is used for an outer layer of armor. The aligned-crystal steel has excellent heat-conducting properties, and so it provides excellent protection against lasers and particle-beam weapons. An inner layer of boron nitride impregnated with diamond monofilament stops high-explosive armor-piercing (HEAP) rounds and fast neutrons. This second layer of armor also prevents any armor fragments from damaging the BattleMech's internal systems.

BattleMechs usually carry charged-particle-beam weapons or lasers as their primary armaments, because energy weapons can be powered virtually indefinitely by a 'Mech's onboard fusion reactor and do not require ammunition reloads. In addition to energy weapons, many BattleMechs carry launching racks for short- or long-range, non-nuclear missiles. Still other 'Mechs mount rapid-fire autocannons or machine guns for use against infantry, aircraft and other BattleMechs.

## Weapons and Heat-Dissipation Strategies

Because a BattleMech's systems are pushed to their limits during combat, 'Mechs engaged in combat generate large amounts of waste heat rapidly. We've already discussed how excessive internal temperatures can disrupt a fusion reactor's magnetic containment shields. But excessive heat can also impair or permanently damage a 'Mech's electronics and computer systems, slowing the BattleMech's movement and reducing the accuracy of its weapons.

Heat sinks are one way of controlling the heat build-up in a 'Mech. But the heat pouring out of these radiators can produce strong infrared (IR) signatures, which can make a 'Mech easy to target. To solve this problem, MechWarriors have found other ways to control heat build-up. Often, MechWarriors will place their machines in shallow lakes or rivers, if possible. Through the processes of conduction and convec-

tion, the running water helps dissipate the 'Mech's internal heat, allowing a higher rate of activity. On temperate or cold worlds, the atmosphere itself can help dissipate waste heat in the same manner. On the other hand, the high outside temperatures of a desert or jungle environment can exacerbate a BattleMech's heating problems.

Perhaps the most common way MechWarriors control heat build-up is by regulating the movement and firing rates of their machines manually or by reprogramming the machine's movement control computer and its secondary systems. These computers can be used to limit the 'Mech's rate of activity and the resulting heat build-up. For example, when a 'Mech is sent to a high-temperature world, its activity-rate setting may be lowered. The 'Mech will move more slowly and fire less often than it would on a temperate planet. When a 'Mech is sent to fight in an arctic climate, the setting is raised, allowing faster movement and a higher rate of fire. Reprogramming is usually carried out while the BattleMech force is enroute to its assignment aboard DropShips. The process takes approximately two weeks.

Because BattleMechs are always adjusted for the expected external temperature of their combat environments, sudden increases in outside temperature can have a devastating impact on a 'Mech's ability to dissipate waste heat. Tacticians have developed a whole series of battle tactics to take advantage of this 'Mech characteristic. For example, commanders regularly set forests on fire while enemy BattleMechs are advancing through them. The superheated air roaring around the 'Mechs can overload the machine's cooling systems or drastically reduce their efficiency, thus hampering the machines' combat capabilities.

## Power

BattleMechs require a large, constant power supply for movement and combat. The fusion reactor, which produces enormous amounts of electricity from ordinary water, is the most efficient system for providing this power. And because the fusion reaction created by a BattleMech's power plant does not release neutrons, the power plant can operate indefinitely without becoming radioactive.

The fusion plant produces electricity by a process known as magnetohydrodynamics. In this process, magnetic fields are used to channel plasma from the fusion reaction into a loop. This plasma is electrically conductive, and so the loop functions as a powerful generating coil, producing both electricity and waste heat. Every BattleMech carries radiators called heat sinks to help dissipate this waste heat. Heat sinks are especially important, because excessively high internal temperatures can disrupt the magnetic containment fields around a BattleMech's reactor. And if a power plant's magnetic "jar" is disrupted, an uncontrolled fusion reaction may occur, releasing neutrons and exposing the BattleMech's internal systems and its crew to damaging and lethal radiation.

## Movement

BattleMechs can attain walking or running speeds ranging from 40 to 100 kilometers per hour in open terrain. Dense forests, swamps, and steep slopes will slow a 'Mech, but very few terrain features can stop one. In addition, many 'Mechs can jump over obstacles by superheating air with their fusion reactors and jetting it out through so-called jump jets. Jump-capable BattleMechs operating on worlds without atmos-

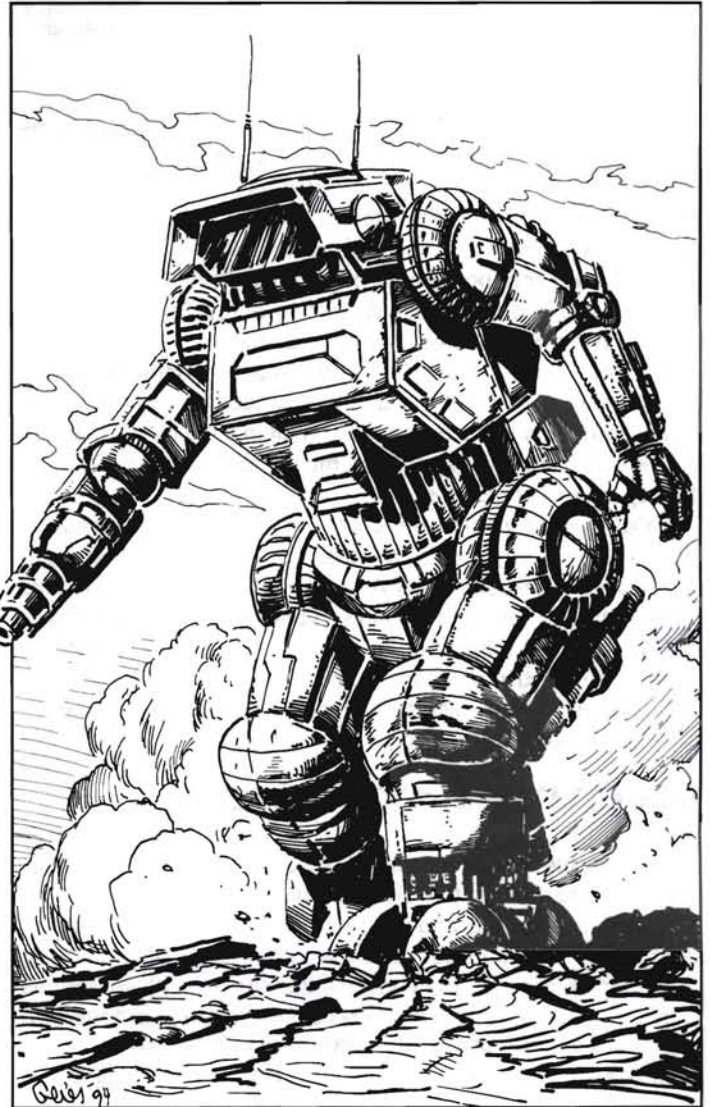

pheres often carry small quantities of mercury to use as reaction mass for their jets. And all BattleMechs can move underwater when crossing rivers or small lakes.

Spaceborne BattleMechs can make assault landings from low orbit. Special reaction jets housed in their feet allow them to soft-land from altitudes of up to 320 kilometers. During re-entry, breakaway ablative shields protect a BattleMech's vulnerable sensors and weapons.

## CONCLUSION

The BattleMech has come a long way since the *Mackie*, and undoubtedly will evolve in directions we can only guess at today. Skobel is proud to have played a part in the development of these technological wonders and looks forward to playing a continuing role in the continuing saga of the BattleMech.

To obtain extra copies of this pamphlet or information on other free instructional materials, ask your teacher to contact the Skobel representative in your area.

## COMBAT

After the players complete the Movement Phase of the turn, units engage in combat. **BattleTech** units use two forms of combat: weapon attacks and physical attacks. Units make weapon attacks using armaments such as missiles, lasers, and autocannons. For physical attacks, the BattleMechs use their own massive weight to inflict damage on targets.

In **BattleTech**, both weapon and physical attacks first inflict damage on the outer armor protecting every BattleMech and vehicle. When an attack or series of attacks destroys all of an armor location's Armor Points, any remaining damage affects the internal structure of the unit in that location. Every attack that penetrates a unit's armor may result in a critical hit that can knock out a major weapon or movement system or even destroy the unit completely.

Most infantry units have no armor, and so successful attacks against infantry reduce the number of men in the platoon rather than destroying Armor Points. Battle armor units deflect damage with Armor Points in the same way as vehicles, and an attacker may need to make multiple hits to destroy them. See **Infantry**, p. 64, for details.

Special combat rules for vehicles and infantry appear on pages 62 and 67, respectively.

### ◆ WEAPON ATTACKS

During the Weapon Attack Phase, players use their units' armaments to attempt to inflict damage on targets. For one unit to fire at another, the attacking unit must have a clear line of sight (LOS) to the target, and the target must be within the range and firing arc of the weapons the attacking player wishes to use. The attacking player then calculates the likelihood of a shot hitting the target based on the range to the target, movement of the target and attacker, intervening terrain, and other factors.

A unit cannot make a weapon attack against another unit occupying the same hex as the attacker. (See **Infantry** for exceptions.)

Players fire each weapon on a unit individually, and can fire as many or as few of their unit's weapons at the target as they wish, within the restrictions described below. Unless otherwise stated in the rules, each weapon may be fired only once per turn.

If the attack hits the target, the attacking player determines the damage location, and the target player records the result on the damaged unit's record sheet.

### ◆ LINE OF SIGHT

When a player decides to fire on a unit, he must first determine whether or not his unit can see its intended target. Various terrain features can fully or partially block a unit's line of sight (LOS) to a target, making a shot difficult or even impossible.

Players can check LOS by laying a straightedge (a ruler or a sheet of paper, for example) from the center of the attacker's hex to the center of the target's hex. Any hex that the straightedge crosses lies on the LOS. If the straightedge passes directly between two hexes, the defender chooses which hex it passes through. The players then check the terrain that lies between their units for intervening features high enough to block LOS, using the following rules:

- A standing BattleMech rises 2 levels higher than the terrain on which it is standing. However, because most BattleMechs' armaments are mounted in the torso and arms, players should consider a 'Mech to be 1 level higher than the terrain it is standing on when determining line of sight, as though LOS were measured from the unit's waist. For example, if a 'Mech is standing on Level 2 terrain, it is 3 elevation levels high for purposes of determining line of sight. If standing on top of a Level 3 building located on Level 1 terrain, consider the BattleMech 5 levels high (1 + 3 + 1) when determining line of sight.

- All terrain has an elevation. If its level is not marked on the map, it is 0.

- Buildings add their elevation level to the elevation level of the terrain on which they stand.

- All woods are considered to be 2 levels tall. Units can fire through certain types of woods (see below). Woods that block LOS add 2 levels to the level of the terrain on which they stand. Units occupying wooded hexes are standing on the underlying terrain, not on top of the trees.

- If the attacker and target units occupy adjacent hexes, both units always have LOS to each other.

- If any intervening terrain is higher than both units, that terrain blocks LOS.

- No single wooded hex blocks LOS. However, if any three wooded hexes (or any two wooded hexes, if one of them is heavy woods) intervene between the attacker and the target, LOS is blocked. Woods in the target's hex and wooded hexes intervening between the attacker and target that are not dense enough to block LOS still make the attack more difficult (see **To-Hit Modifiers**, p. 35).

- If the terrain in the hex adjacent to the attacker through which LOS is traced is higher than the attacker, then LOS is blocked. If the hex adjacent to the target through which LOS is traced has a higher elevation than the target, then LOS is blocked. Note that because no single wooded hex can block LOS, an adjacent wooded hex does not block LOS according to this rule.

- Intervening units never block LOS.

Water hexes and partial cover have unique effects on line of sight that are explained below.

**COMBAT**

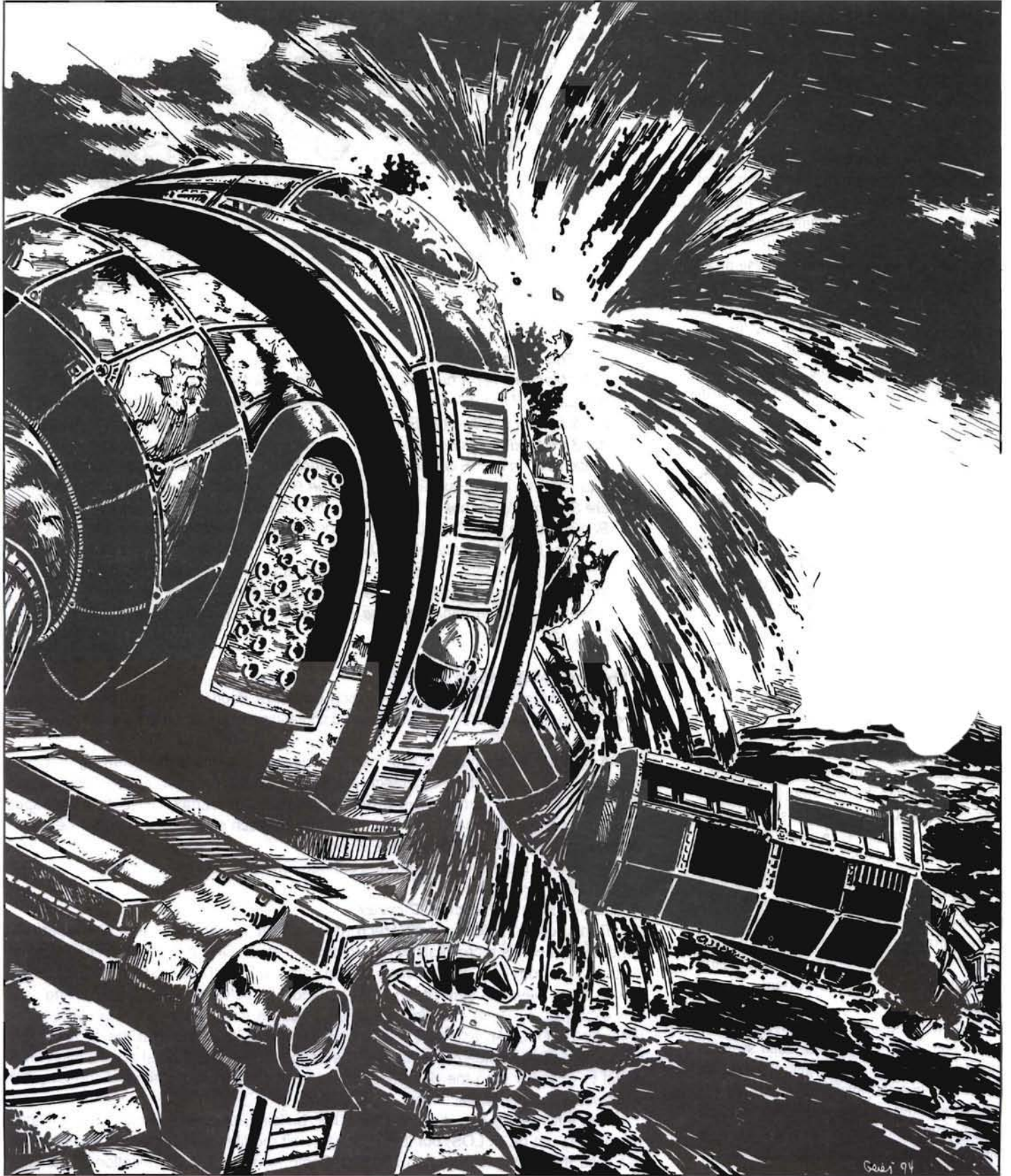

Geis 94

## WOLFNET ARCHIVE FILE: 67743-FS2-33/7/0

From an article appearing in *MechTech*, a bimonthly science magazine catering to MechWarriors, technicians, and BattleMech enthusiasts

In spite of recent advances in BattleMech technology, the basic element of a 'Mech's control system—the neural-impulse helmet—has remained unchanged since the start of the Succession Wars. Commonly called neurohelmets, these bulky items normally cover a MechWarrior's entire head, attaching firmly to the shoulders of his cooling vest. Relatively lighter, more compact models manufactured during the days of the Star League are still in use, but even these helmets are heavy and uncomfortable.

Electrodes on the interior of the neuro-helmet channel sensory information from the BattleMech directly to the pilot, converting raw data on posture, movement, balance and speed into neural impulses for the human brain. At the same time, the helmet and its linked computer translate impulses from the MechWarrior's brain into signals transmitted directly to the 'Mech's gyroscope and myomer musculature. In this way, the reflexive bodily movements of the BattleMech are controlled subconsciously by the pilot, leaving his conscious brain free to control the various weapons and other systems as needed.

Recently, rumors have begun circulating about advances in the science of neural control achieved by the Clans. A source attached to the First Somerset Strikers reported that certain Clan pilots have been sighted "wearing no neurohelmets while operating their 'Mechs, instead relying on a delicate web of conductive fibers attached to their shaved heads. These neural nets superficially resemble face paint, and indeed we initially thought our opponents were using some strange system of tribal markings ..."

Regardless of the veracity of these claims and others like them, such systems must only exist as prototypes, if at all. No solid facts are yet available regarding the combat effectiveness or adaptability of these new systems. As always, our readers will be the first to hear of any new developments.

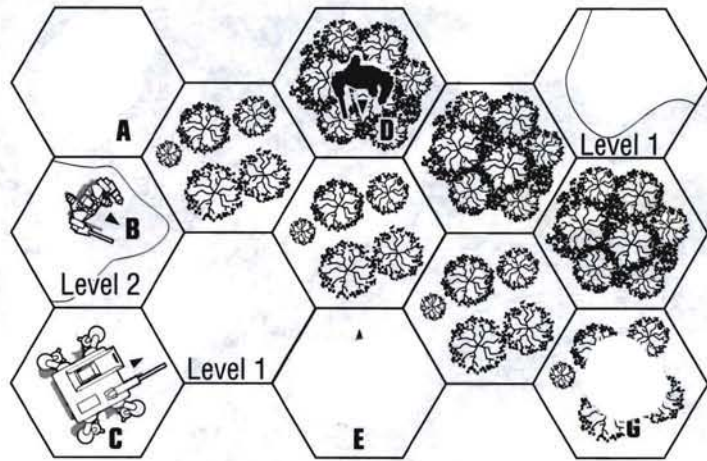

This diagram illustrates some of the principles governing LOS. The BattleMech in Hex A has line of sight to the BattleMechs in Hexes B, D, E, and F because of the following conditions. Even though 3 wooded hexes normally block LOS, it can see the BattleMech in Hex F because the elevation levels of the 3 wooded hexes between them are not higher than both BattleMechs. The BattleMech in Hex F is visible to the BattleMech in Hex E for the same reason. The BattleMech in Hex A cannot see the BattleMech in Hex G because there are 3 Light Woods hexes between the two BattleMechs, and it cannot see the BattleMech in Hex C because the level of Hex B, which is adjacent to Hex A, is higher than the BattleMech in Hex A.

The BattleMech in Hex C cannot see the BattleMech in Hex A because the adjacent hex has a higher elevation level. The BattleMech in Hex C does, however, have an unblocked line of sight to the BattleMechs in Hexes B, D, E, F, and G.

### Effects of Water Hexes

Water hexes have negative elevation levels, or depths, of 0 and below. Treat a hex's depth as a negative number when calculating the elevation differences between two units.

A Depth 1 Water hex provides partial cover for a BattleMech occupying that hex. Because only part of the BattleMech presents a possible target, add a partial cover modifier to the to-hit number (see **Effects of Partial Cover**, below). Depth 2 or deeper water completely blocks LOS to and from a BattleMech standing in a Water hex. See **Underwater Operations**, p. 95, for exceptions.

Hovercraft moving over water and surface naval vessels are at Level 0.

### ◆ Effects of Partial Cover

Partial cover makes a BattleMech harder to hit, but any shot that hits a partially concealed 'Mech is more likely to hit a critical location. Only a BattleMech can receive partial cover from terrain. To receive partial cover, a BattleMech must be adjacent to a hex of equal elevation to itself, and that hex must lie between it and the attacking unit. For example, a 'Mech standing on Level 0 terrain has an Elevation Level of 1 for determining LOS. An adjacent hex of Level 1 terrain lying between the attacker and the target would provide partial cover. The firing unit must also be at an elevation level equal to or lower than the defending unit. In other words, an attacker firing downhill negates its target's partial cover.

The intervening elevation can be a hill, building, or combination of both. Partial cover does not block LOS, but it adds a +3 to-hit modifier to the attacker's to-hit number. Use the BattleMech Punch Location Table to determine the location of damage

# COMBAT

inflicted on a partially concealed target. A partially concealed BattleMech's legs cannot be hit. (See **To-Hit Modifiers**, p. 35, for further explanation.) Add a +2 to-hit modifier for partial cover for attacks made against BattleMechs standing in Depth 1 water [(+3 for partial cover) + (-1 for being in water) = +2]. A BattleMech does not receive partial cover from woods.

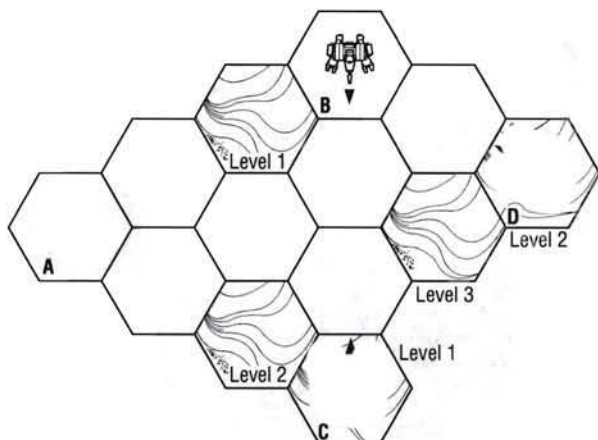

*The BattleMechs in Hexes B, C, and D have partial cover from the BattleMech in Hex A because each is adjacent to a hex equal to its own elevation along the LOS from the BattleMech in Hex A.*

## FIRING ARCS

When the player determines that his unit can see its intended target, he must then determine in which of his weapons' firing arcs the target lies. Only those weapons that can be brought to bear on the target can be used to attack the target.

BattleMech firing arcs take advantage of the nature of arm-mounted weapons by firing into four basic arcs: the front and rear arcs, and the right side and left side arcs, as shown in the diagram.

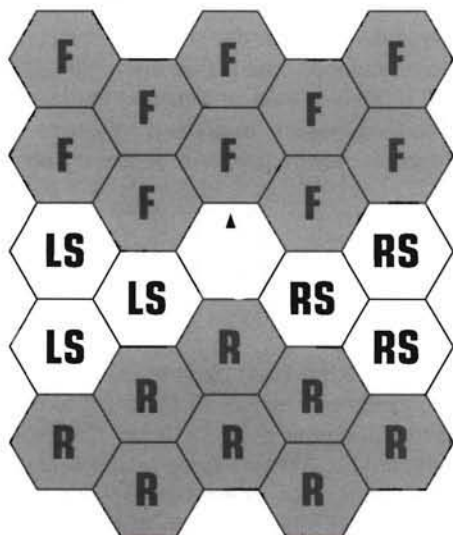

Weapons mounted in the three forward torso locations, the legs, or the head of a BattleMech may only fire into the forward arc. Weapons mounted on the right arm may fire into the forward arc and the right side arc (RS). Weapons mounted on the left arm may fire into the forward arc and the left side arc (LS).

Weapons mounted in one of the three rear torso locations and the rear of the legs and head of a BattleMech (indicated by (R) on the record sheet) may only fire into the rear arc.

A BattleMech with leg-mounted weapons may not fire through a hex that would provide that BattleMech with partial cover.

Vehicle weapons mounted in the front may only fire into the forward arc. Weapons mounted on the right side or left side may only fire into the right and left arcs, respectively. Rear-mounted weapons fire into the rear arc.

Infantry do not have any firing arc restrictions.

## Rotating the Firing Arcs

BattleMechs can rotate their torso one hexside to the left or right while keeping their feet pointed straight ahead during the Reaction Phase. This means that a BattleMech can move in one direction while firing in another. A BattleMech's upper-body firing arcs are determined by the direction in which its torso is turned, not by the 'Mech's facing; leg-mounted weapon firing arcs are always aligned with the feet.

When the BattleMech's torso rotates, all upper-body firing arcs rotate with it as shown on the diagram.

Prone 'Mechs may not twist their torsos.

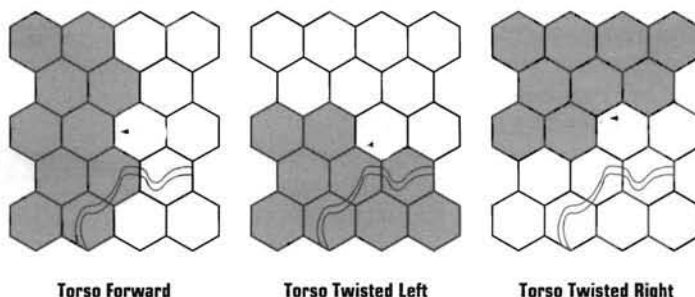

Turret-mounted weapons in vehicles can be pointed to fire through any hexside, per the **Torso Twist/Turret Rotation** rules, p. 24. Treat turret arcs like the front arc, except that they are defined by the hexside at which the turret is currently pointing, not the hexside toward which the vehicle is facing.

## FIRING WEAPONS

After a player has determined that a target is within line of sight and the firing arcs of his weapons, the unit may make one or more weapon attacks. The player uses the MechWarrior's Gunnery skill as the base to-hit number for each attack. For each weapon he will fire, the player determines if the shot is more or less difficult than normal by factoring in range, terrain, movement, and other conditions. These factors will add modifiers to the base to-hit number to create a modified to-hit number.

WOLFNET ARCHIVE FILE: 55897-FE-51/11/09

From a compilation of initial field reports describing OmniMechs

PRELIMINARY REPORT NO. A-345/782  
TO: Commander Geoff North  
FROM: Sergeant Iokawa

The Clans' stunning success so far can be attributed mainly to the OmniMech. If we could reproduce even some of the features of these amazing machines, it would even our odds in the fight against the Clans (and give us an edge in our struggle against the other Successor States, which must someday resume).

The Clans' primary innovation is modular weapons and other equipment. The ability to constantly reconfigure a single 'Mech has at least three obvious advantages.

1. 'Mech can be tailored to suit each expected mission. Thus, the same machine that provides fire support one day can face urban sappers the next with equal effectiveness.

2. Greatly simplifies repair and maintenance. Because most of its parts are modular, they can be serviced independently, which means the 'Mech spends more time in the field. Replacing a damaged limb or malfunctioning weapon becomes a quick field repair that can immediately bring a 'Mech back to peak or near-peak efficiency.

3. Can be easily outfitted to meet pilot preference. While this may seem a minor point, statistics prove that many Mech-Warriors perform better using certain types of weapons. Modular configuration would allow techs to support those preferences and so improve (one would suppose) overall troop performance.



ber. The more difficult the shot is because of distance, concealment by terrain, or movement, the higher the modified to-hit number. The player then rolls 2D6 to see if the attack hits the target. If the result is greater than or equal to the modified to-hit number, the attack hits its target. If the fired weapon requires ammunition, the player marks off one shot of ammunition. Weapons may be fired only once per turn.

#### ◆ Base To-Hit Number

The base to-hit number for a weapon attack is equal to the firing pilot's Gunnery Skill level. For exceptions, see **Infantry**, p. 64.

#### ◆ Modified To-Hit Number

The modified to-hit number equals the base to-hit number plus all modifiers for range, minimum range, movement, concealment, and other factors discussed in **To-Hit Modifiers**, below. If the modified to-hit number is greater than 12, the shot automatically misses. If a player determines that his unit's declared attack will automatically miss, he can choose not to make the attack, thereby avoiding wasting the ammunition and building up heat. He may not switch his attack to another target.

# COMBAT

## To-Hit Modifiers

The base to-hit number may be modified by a number of factors, including range, terrain, movement, multiple targets, heat and damage, and prone and immobile targets. All modifiers are cumulative.

◆ **Range Modifier:** The farther away the target is from the firing unit, the more difficult it will be to hit. The range modifier for an attack is determined by the range to the target, which is the distance between the attacking unit and its target. To determine range, begin at the hex adjacent to the attacker's hex along the line of sight, find the shortest path to the target, and count the number of hexes between those two points, including the target's hex.

The ranges for all available weapons appear in the Weapons and Equipment Tables, beginning on p. 104 in **Construction**. A weapon's maximum range is divided into three distances: short, medium, and long. Find the distance to the target in the row for the appropriate weapon, and determine if the unit's current range is short, medium, long, or out of range. A shot at short range requires no to-hit modifier. A medium-range shot has a +2 to-hit modifier, while a shot at long range has a +4 modifier.

Weapons cannot hit a target at a distance greater than the weapon's long range, but units may fire at targets beyond long range just to get rid of ammunition.

**Minimum Range Modifier:** Some weapons, such as particle projector cannons, autocannons, and long-range missiles (LRMs), are designed to be fired at long-range targets. When fired at close-range targets, they lose much of their effectiveness. The minimum effective range of each available weapon, the range at which the weapon becomes less effective than normal, appears in the Weapons and Equipment Tables, p. 104.

If the target occupies the hex indicated as the minimum effective range, modify the to-hit number by +1. For every hex closer to the firer, add an additional +1 to the to-hit number. This represents the fact that it is harder to hit targets with some weapons at very close ranges than at maximum range.

*A particle projector cannon (PPC) has a minimum effective range of 3 hexes. If a Warhammer is firing a PPC at a Crusader 3 hexes away, it adds a Minimum Range Modifier of +1 to its to-hit number. If the Crusader is only 2 hexes away, the modifier is +2. If the target is 1 hex away, the modifier is +3.*



*If the Warhammer in the example allows its target to move to within 2 hexes of its position, the player must modify the unit's to-hit number because the target stands inside its weapon's minimum effective range. The Base To-Hit Number is 4 because the*

*MechWarrior's Gunnery Skill level is 4, and the Minimum Range Modifier is +2. This gives the attacking Warhammer a Modified To-Hit Number of 6, the same as if the target were at medium range.*

**Movement Modifiers:** A moving target is harder to hit, and a moving attacker must constantly adjust his aim to compensate for his movement. To reflect this, a unit's to-hit number is modified by the movement of the attacking BattleMech and its target's movement, using the values found in the Weapons Fire Modifiers Table.

The target movement modifiers are based on the hexes traversed during the movement phase rather than the number of Movement Points spent. If the target moved both backward and forward in the turn, base the movement modifier on the number of hexes moved from the hex in which the unit last reversed its movement. For example, if the target moved backward 3 hexes and then forward 2 hexes, the target movement modifier would be based only on the final 2 hexes of movement, resulting in a Target Movement Modifier of 0.

Note that if the target jumped in the current turn, the player must add a jump modifier in addition to the modifier for the number of hexes moved.

*During the Movement Phase, the attacking Warhammer from the previous example walked (+1 modifier), and its target moved a total of 4 hexes (+1 modifier). The combined movement modifier is +2. This modifier is added to the base to-hit number. This means that when the Warhammer fires his PPC at the Crusader, which is 2 hexes away, he uses a Modified To-Hit Number of 8 [4 (base to-hit) + 2 (minimum range modifier) + 2 (movement modifier)].*

**Terrain Modifiers:** Terrain can affect the probability of a successful shot by forcing the attacker to account for intervening land features and partial cover. Units can shoot through Light and Heavy Woods hexes under certain circumstances, but successful shots become more difficult the more wooded hexes lie between an attacker and its target. Water generally makes a BattleMech harder to hit, as does partial cover. Specific terrain modifiers appear below.

• **Light Woods.** Modify the to-hit number by +1 per hex of light woods between the attacker and the target. (If the treetops lie below the LOS between the units, do not apply this modifier.) Add an additional terrain modifier of +1 if the target occupies a Light Woods hex. The attacker may fire through up to 2 intervening Light Woods hexes as long as the modified to-hit number is less than 13.

• **Heavy Woods.** Modify the to-hit number by +2 per hex of heavy woods between the attacker and its target. (If the treetops lie below the LOS between the units, do not apply this modifier.) If more than 1 Heavy Woods hex lies between the attacker and the target, line of sight is blocked. Add an additional terrain modifier of +2 if the target occupies a Heavy Woods hex.

WOLFNET ARCHIVE FILE: 88675-RE4-31/1/5

## Copy of a memo circulating in AFFC units

FROM: Field Master Jessup Winston, Dept. of the Army and Navy  
RE: Advancements in Battlefield Technology

It has come to our attention that too many House units remain either unaware of or unable to obtain cutting-edge technologies made possible by the recent completion of research projects by the New Avalon Institute of Science. Both the Gray Death memory core and the study of captured Clan equipment have enabled us to drastically improve the technologies of war, but our narrowing of the gap between the Inner Sphere and the Clan enemy will do us no good unless all fighting units adopt the latest designs.

The following new weapons systems and war machines represent only the tip of the iceberg.

A particularly promising weapon is the LB-10X autocannon, which counters the tremendous range advantage of Clan weapons. Every effort will be made by this office to get this weapon into the hands of all field units. With regard to naval assets, which the High Command believes will play a vital role in the renewed Clan conflict, the upgraded *Gazelle* DropShip remains one of the most versatile and useful vessels in current service. The upgrade significantly beefs up the *Gazelle's* limited weapons array; New Syrtis Shipyards have begun to mass-produce *Gazelles* within the past year.

With regard to BattleMech refits, commanders may have trouble procuring the necessary kits. The Free Worlds League, with whom relations are somewhat tense, produces the bulk of the current high-tech refit kits for BattleMechs. Because it remained largely unaffected by the Clan War, the Free Worlds League retooled its factories more quickly than the other Successor States, and so remains the primary seller of upgraded 'Mech technologies. So far, the Marik government has valued export revenues over political considerations, but we cannot expect this situation to continue indefinitely. AFFC commanders may rest assured that this office is making every effort to reduce our dependence on Free Worlds League products.

- **Water.** Units in Water hexes find movement difficult. The effect of moving through water is to limit their ability to avoid incoming effective attacks and launch effective attacks of their own. Add a terrain modifier of +1 to the to-hit number if the attacker is in a Water hex of Depth 1. Modify the to-hit number by -1 if the target occupies a Water hex of Depth 1. Because a BattleMech also receives a +3 partial cover modifier for standing in a Depth 1 Water hex, it would have a total terrain modifier of +2.

Water of Depth 0 has no effect on the to-hit number.

A BattleMech standing in a Depth 2 (or deeper) Water hex cannot fire on or be fired on by other units. See **Underwater Operations**, p. 95, for exceptions.

Hovercraft moving over water are considered to be at Depth 0 regardless of the actual depth of the Water hex they occupy.

- **Partial Cover.** Add a terrain modifier of +3 to the to-hit number if the target BattleMech is partially concealed (see **Line of Sight**, p. 30). When a BattleMech receives the partial cover modifier, resolve all damage on the BattleMech Punch Location Table, p. 46.

**Multiple Targets Modifier:** A player may declare that his BattleMech or vehicle will engage more than one target in a turn and allocate different weapons systems to fire at different targets.

For a BattleMech or vehicle to fire at more than one target, the multiple targets must all appear in the unit's front firing arc. The player designates one of the targets as the primary target. The remaining targets are considered secondary targets, and the player must add a +1 multiple targets modifier to the to-hit numbers for those attacks. This modifier is not cumulative—the modifier for the third and subsequent targets is still only +1.

This multiple targets modifier does not apply to physical attacks in any way.

Infantry may only engage one target per turn.

**Heat and Damage Modifiers:** The attacking BattleMech may be forced to modify its base to-hit number for current combat damage and heat build-up. Modifiers for these conditions are discussed in **BattleMech Critical Hits**, p. 42, and **Building Up Heat**, p. 53. The Heat Scale section of the record sheets summarizes the modifiers for the effects of heat build-up. Note that some BattleMechs are designed without certain arm actuators and do not suffer the +1 modifier for that actuator being destroyed.

- ◆ **Firing at Immobile Targets:** If a unit chooses to fire at an immobile target such as a building, a wooded hex, or a unit that is shut down or whose crew is unconscious, add a -4 modifier to the to-hit number. Note that this modifier does not apply to attacks against active units that are simply remaining stationary, nor does it apply to prone BattleMechs or 'Mechs with destroyed gyros or two destroyed hip actuators. Such units are still assumed to be moving within their hex and must be fired upon as for a normal target.

### Prone BattleMechs

Prone BattleMechs may still make weapons attacks, and, because they are largely stationary, they often make better targets.

- ◆ **Firing When Down:** A BattleMech that has fallen or dropped to the ground may fire some of its weapons as long as neither of its arms has been destroyed. The pilot uses one arm to support the BattleMech as it fires, and so the weapons on that arm cannot fire. The pilot may fire all the weapons mounted on the other arm, and the BattleMech may fire any weapons mounted in its head or torso. A prone BattleMech may not fire its leg-mounted weapons. Add a +2 to-hit modifier for firing when down.

- ◆ **Attacking Prone Targets:** A BattleMech that has fallen or is prone makes an easier target for an opponent in an adjacent hex, and a more difficult target at longer ranges. Apply a -2 modifier to the to-hit number of any physical or weapon attack

# COMBAT

made against a prone BattleMech from an adjacent hex. Add a +1 to-hit modifier for all other attacks made against a prone 'Mech.

Use the BattleMech Hit Location Table, p. 39, in the normal manner for determining the hit location. Note that the facing of a prone BattleMech is determined in **Facing after a Fall**, p. 27.

The only physical attacks that can be made against a prone BattleMech are kicking, charging, or death from above. Determine the location of successful attacks of this type using the appropriate column of the BattleMech Hit Location Table. Note that hit location from death from above attacks against prone 'Mechs is determined using the Rear column of the table, regardless of the attack direction.

*A Warhammer carrying a pilot with a Gunnery Skill of 4 declares it will fire its PPC at a Crusader 2 hexes away (+2 minimum range modifier), with 2 hexes of Heavy Woods giving the Crusader cover (1 hex between the two 'Mechs and the hex the Crusader occupies, a +4 terrain modifier). The Warhammer walked in this turn (+1 movement modifier), and the Crusader jumped (+1 movement modifier) 4 hexes (+1 movement modifier). This makes the Modified To-Hit Number 13 (4 + 2 + 4 + 1 + 1 + 1 = 13), which means the shot will automatically miss. The Warhammer pilot prudently decides to abort the attack, avoiding the PPC's massive heat build-up.*

## WEAPONS FIRE MODIFIERS TABLE

Attacker	Modifier
Movement	
Stationary	None
Walked	+1
Ran	+2
Jumped	+3
BattleMech Damage	
Sensor Hit	+2
Shoulder	+4 for weapons in arm
Arm Actuator (each)	+1 for weapons in arm
Heat	
8-12	+1
13-16	+2
17-23	+3
24+	+4
Prone	+2
<b>Range and Terrain</b>	
Range	
Short	None
Medium	+2
Long	+4
Minimum Range	+1 at minimum range, additional +1 per hex less than minimum range
Light Woods	+1 per intervening hex; +1 if target in Light Woods
Heavy Woods	+2 per intervening hex; +2 if target in Heavy Woods
Water	
Depth 1	-1 to hit a BattleMech in Water hex; use BattleMech Punch Location Table
Depth 2	+1 to hit for BattleMech firing from Water hex BattleMechs cannot fire into or out of Depth 2+ water
<b>Target</b>	
Partial Cover	+3 (use BattleMech Punch Location Table)
Prone	-2 from adjacent hex; +1 from all others
Secondary Target	+1
Immobile	-4
Movement	
Moved 0-2 hexes	0
Moved 3-4 hexes	+1
Moved 5-6 hexes	+2
Moved 7-9 hexes	+3
Moved 10+ hexes	+4
Jumped	+1

WOLFNET ARCHIVE FILE: 28876-RD6-54/7/1

From *Federated Commonwealth in Chaos*,  
by Shintaro Maku (Combine Press, 3056)

The Federated Commonwealth stretches across the Inner Sphere and borders all other states. This union of House Davion's Federated Suns and House Steiner's Lyran Commonwealth, sealed by the marriage of Hanse Davion to Melissa Steiner, sparked the Fourth Succession War, whose territorial gains united the two realms geographically as well as politically. During the Clan invasion, the Lyran half of the Commonwealth lost several important worlds to Clans Jade Falcon and Wolf, and these losses fueled resentment between the Commonwealth's two halves.

Until recently, the Federated Commonwealth remained united under Archon Prince Victor Steiner-Davion. Victor is devoted to his realm, and his many supporters vouch for his effectiveness as a ruler, but Victor recently acknowledged his critics by agreeing to rule from the Davion capital of New Avalon and appointing his sister Katherine regent on the Lyran capital of Tharkad.

Initially, Katherine's appointment calmed the secessionists who have always troubled the Federated Commonwealth. When secessionists in the Lyran Isle of Skye region rebelled against Victor, however, the actions he took to put down the rebellion alienated the Lyran people. Upon the revelation that Victor concealed the death of Joshua Marik from Joshua's father and substituted a double for the child, the Lyran state seceded from the Federated Commonwealth, renamed itself the Lyran Alliance, and ceded back to House Marik many of the Free Worlds League planets captured during the Fourth Succession War. Katherine also refused to aid Victor against the recent Capellan offensive.

Alliance troops and Federated Commonwealth loyalists currently remain at peace. However, the loyalties of various units remain unknown. More disturbing is the turmoil on the planets in the Terran corridor and the Tikonov March. Factions on these worlds are vying for control, and no end to the disruption in this Chaos March is in sight. Currently, Prince Victor is reorganizing his loyalists to face Liao and Marik assaults launched to consolidate their hold on their regained territory.

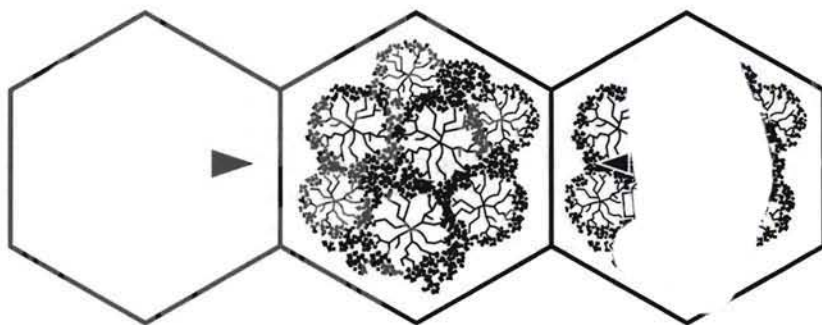

## TO-HIT ROLL

For each attack, the player makes a to-hit roll by rolling 2D6. If the result is equal to or greater than the modified to-hit number, the attack succeeds.

## Missile Hits

When a player launches a missile attack, the damage inflicted by a hit (a successful attack) depends on how many of the fired missiles actually reached the target.

To make a missile attack, the player calculates the modified to-hit number and makes the to-hit roll, just as for other weapons. On a successful attack, the player must also determine how many of the missiles hit the target by rolling 2D6 and consulting the Missile Hits Table.

First, find the number of missiles fired on the top row of the table. Cross-refer this number to the dice roll result in the left column. The result is the number of missiles that actually hit the target. Note that some advanced weapon systems modify this roll to reflect their greater accuracy. Also, the target's anti-missile systems may reduce the number of missiles that actually hit. See **Equipment**, p. 112, for details.

### MISSILE HITS TABLE

Dice Roll (2D6)	Number of Missiles Fired						
	2	4	5	6	10	15	20
2	1	1	1	2	3	5	6
3	1	2	2	2	3	5	6
4	1	2	2	3	4	6	9
5	1	2	3	3	6	9	12
6	1	2	3	4	6	9	12
7	1	3	3	4	6	9	12
8	2	3	3	4	6	9	12
9	2	3	4	5	8	12	16
10	2	3	4	5	8	12	16
11	2	4	5	6	10	15	20
12	2	4	5	6	10	15	20

*An Archer fires its 20-pack long-range missile launcher and hits its target. The attack is successful, and the attacking player must now determine how many of his 20 missiles actually hit the target. He rolls 2D6 with a result of 8. He finds that number in the left-hand column of the Missile Hits Table, then reads across the row to the 20 missiles column, which shows that 12 of his missiles reached their target.*

## HIT LOCATION

When an attack hits its target, the firing player must determine precisely where the attack hit the target. Hit location is determined by the direction of the attack and the facing of the target.

### Attack Direction

When an attack hits a BattleMech or vehicle, it hits from either the front, rear, left, or right side of the target.

Lay a straightedge from the center of the attacker's hex to the center of the target's hex. Compare the hexside crossed by the straightedge to the diagram below to find the side of the unit hit by the fire. If the straightedge crosses exactly at the intersection of two sides, the defender chooses which side is hit by the attack.

To determine which side of a BattleMech is hit, use the facing of a standing BattleMech's feet to determine its Front side, regardless of torso twist. If the target BattleMech is prone, use the hexside toward which its head is pointing as its facing. The side on which a vehicle is hit is based on the alignment of its Front side. Vehicle Hit Location Tables appear in **Vehicles**, p. 63.

Hits on infantry and buildings do not rely on the direction of the attack. Players who make a successful attack against these targets need not determine attack direction or hit location. Detailed explanations for assigning damage to infantry and buildings appear in their respective sections.

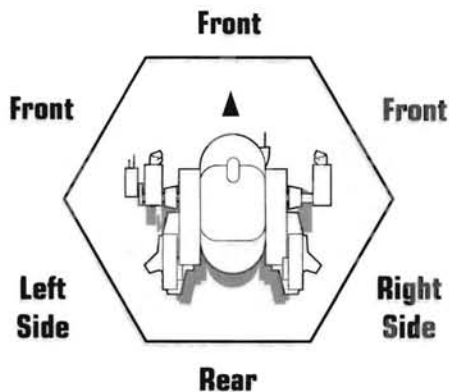

### Determining Hit Location

To determine the exact location of a hit, the attacker rolls 2D6 and consults the appropriate column of the BattleMech or Vehicle Hit Location tables.

In the case of missiles, treat each short-range missile (SRM) and every 5 long-range missiles (LRMs) as a separate attack for purposes of determining hit location. For LRMs, group the missiles that hit into clusters of 5; in other words, form as many 5-point groups as possible, assigning any remaining points to one smaller group, and determine a hit location for each cluster.

## BATTLEMECH HIT LOCATION TABLE

Dice Roll (2D6)	Left Side	Front/Rear	Right Side
2*	L. Torso (critical)	C. Torso (critical)	R. Torso (critical)
3	Left Leg	Right Arm	Right Leg
4	Left Arm	Right Arm	Right Arm
5	Left Arm	Right Leg	Right Arm
6	Left Leg	Right Torso	Right Leg
7	Left Torso	C. Torso	Right Torso
8	C. Torso	Left Torso	C. Torso
9	Right Torso	Left Leg	Left Torso
10	Right Arm	Left Arm	Left Arm
11	Right Leg	Left Arm	Left Leg
12	Head	Head	Head

\*A result of 2 may inflict a critical hit. Apply damage to the armor in that section in the normal manner, but the attacking player also rolls once on the Determining Critical Hits Table, p. 42.

*An Archer hits its target with a medium laser. The straightedge shows that the attack is being made against the target's left side. The attacking player rolls 2D6 to determine the hit location and has a result of 8. Consulting the column for left-side hits, he finds that his medium laser hits the target's center torso.*

### ◆ Aimed Shots

Players may make aimed shots against BattleMechs that are shut down or whose pilots are unconscious using any weapons other than missile launchers and LB-X autocannon firing cluster munitions. When firing on an immobile BattleMech (see **Firing at Immobile Targets**, p. 36), the attacking player can make an aimed shot by naming a target location. The player makes the to-hit roll, using the standard -4 to-hit modifier for firing at an immobile target. If the attack is successful, the player rolls again; on a result of 6, 7, or 8, his shot hits the designated location. For any other result, the player rolls normally on the BattleMech Hit Location Table.

If the attacker is taking an aimed shot at the target BattleMech's head, modify the to-hit number by +3 rather than the normal -4. If the shot hits, the player rolls 2D6. On a result of 8 or greater, the shot hits the head. For any other result, roll normally on the BattleMech Hit Location Table.

If the attacker misses an aimed shot but rolls the intended location on the BattleMech Hit Location Table, the effect is as if the aimed attack succeeded.

Clan targeting computers also allow OmniMech pilots to make attacks against specific locations. See **Equipment**, p. 112, for details.

WOLFNET ARCHIVE FILE: 24431-1S2-33/5/8

**Advertisement published in successive issues of *Merc World* magazine, 3056**

Depending on who you talk to, a mercenary can be anything from a savior to the scum of the universe. On the Wolf's Dragoons world of Outreach, the Mercenary's Star, we know what a merc really is: a businessman.

Tired of fighting for causes you don't believe in, taking orders from fools you can't respect? Look no further, soldier. From garrison duty for a Great House to nailing pirates in the Periphery to fighting off Clan raiders at the edges of the Occupation Zones, Outreach has the job for you. Employers from all over the Inner Sphere gather in the capital city of Harlech, all looking for the best possible warriors at the best possible price. And every contract signed on Outreach has the seal of approval of the Mercenary Review and Bonding Commission. Do right by your employer, and the Commission sees to it that your employer does right by you.

In the Inner Sphere of 3056, the balance of power can change from day to day. Make change work for you, not against you; fight where you want to and get paid what you're worth. No matter where your job may take you, remember that adventure, excitement, and profit all begin in one place: the Mercenary's Star.

## DAMAGE

Each attack that successfully hits the target does damage to the target. Every weapon does a specific amount of damage, which is given on the appropriate Weapons and Equipment Table, beginning p. 104.

Each missile type does the same amount of damage at any range, but the number of missiles that hit determines how much damage a missile attack inflicts. Long-range missiles have a Damage Value of 1 and short-range missiles have a Damage Value of 2 for each missile that hits its target.

## Recording Damage

Every time a location takes damage, the player of the targeted BattleMech or vehicle finds the appropriate hit location on the record sheet's Armor Diagram, then checks off one box on the Armor Diagram at the appropriate location for every point of damage taken. When all the armor boxes at that location have been checked off and the target takes additional damage to that location, the damage transfers to the internal structure of the BattleMech or vehicle, and the player checks off the appropriate number of boxes on the Internal Structure Diagram. When a hit strikes an unarmored location, check off one box in the Internal Structure Diagram per point of damage taken. When all of the internal structure boxes in a given location have been checked off, that location has been destroyed and all its functions are lost. Any weapons, equipment, and heat sinks mounted there are totally destroyed.

If a BattleMech's side torso has all of its internal structure destroyed, the corresponding arm is also blown off (see **BattleMech Critical Hit Effects**, p. 42). The corresponding leg is not damaged.

Hits against infantry and buildings are recorded differently from hits on BattleMechs and vehicles. See **Infantry**, p. 67, and **Buildings**, p. 58, for details.

*A Warhammer's left arm takes hits from a PPC (Damage Value 10), a large laser (Damage Value 8), and two 5-point clusters of LRMs (Damage Value of 1 per missile hit, 5 points per cluster). Before this turn, the BattleMech's 20 Armor points in that arm were undamaged. The cannon hit reduces the Armor points by 10, so 10 boxes are checked off. The laser hit knocks off 8 points, and 8 more boxes are checked off, leaving 2 boxes. The first cluster of missiles then reduces the armor by another 5 points, 3 points more than the remaining armor on that arm.*

*These 3 points reduce the Internal Structure Value, and so 3 boxes are checked off the Internal Structure Diagram, leaving only 8 boxes of the original 11. The last group of missiles reduces the internal structure by another 5 points, and the player checks off 5 more boxes from the Internal Structure Diagram, leaving 3. If the Warhammer's left arm takes a hit from a weapon with a Damage Value of 3 or more, it will be completely destroyed and all of the weapons and other equipment mounted there lost.*

## ◆ Transferring Damage

BattleMechs can survive the destruction of a single body section. If a section is destroyed and the same location takes another hit, or excess damage remains from the shot that destroyed the location, that damage transfers to (affects) the outer armor of the next most logical location. Excess ammunition-explosion damage is transferred directly to the internal structure of the next most logical location.

Damage to a missing arm or leg transfers to the torso on the same side (left leg or arm damage is transferred to the left torso, and so on). Additional damage to a destroyed side torso location transfers to the center torso.

Damage from the rear firing arc that hits a missing limb is transferred to the appropriate rear torso location. For example, damage from the rear that hits a missing left leg would be transferred into the left rear torso.

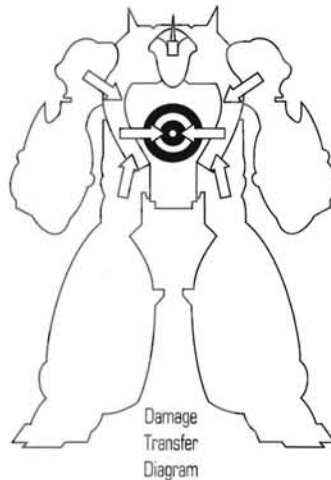

## CRITICAL DAMAGE

Every time the internal structure of a BattleMech or vehicle takes damage, either from a weapon attack, physical attack, or an ammo explosion triggered by excess heat, an internal component may take critical damage.

To determine whether a unit's internal structure takes critical damage from a successful attack, the attacking player rolls 2D6 and consults the Determining Critical Hits Table. On a result of 8 or

higher, the target unit takes critical damage. The higher the result, the more serious the damage. If the unit takes critical damage, the defending player rolls 2D6 and consults the unit's Critical Hit Table to determine the precise location of the damage.

Each successful attack that damages internal structure creates only one chance for the attacker to inflict a critical hit, regardless of the number of internal structure boxes that a single weapon (or other attack) destroyed. That player rolls 2D6 only once. Units may also take critical damage if the attacking player rolls certain results on the various Hit Location Tables.

The location of the damage determines the exact nature of the critical hit. Each part of a BattleMech's body can be affected by several types of critical hits. Furthermore, every type of BattleMech can suffer different critical hits, depending on the array of weapons and other equipment it carries. The Critical Hit Table for each type of BattleMech appears on the record sheet for that type. A partially blank Critical Hit Table that can be customized for all BattleMechs is provided on all blank BattleMech Record Sheets. The Critical Hit Tables for the various types of vehicles appear in **Vehicles**, p. 63.

WOLFNET ARCHIVE FILE: 12245-PT4-32/9/1

From *Smart Nations, Foolish Choices*, a political pamphlet currently circulating in the Isle of Skye region, Federated Commonwealth

From the 24th century almost to the present day, five families have ruled most of known space. Each of the five realms that we now call the Successor States owes its existence and prosperity to its founding family, and the people of those realms owe loyalty to the heirs of their nation's builders. For hundreds of years, Steiners have ruled the worlds of the Lyran Commonwealth and Davions have ruled the worlds of the Federated Suns. We citizens of Steiner planets are patriotic subjects of the Steiner family—how can we accept a half-Davion princeling as our great nation's legitimate ruler?

In ancient times on Terra, feudal lords commanded the fealty of those they ruled. In return, the lords protected their people and saw to their comfort. The Steiner family has certainly lived up to its end of the bargain—they have given us a nation both powerful and rich to call home. The Davions have given us nothing. They have seen only to the welfare of their own citizens. Therefore, it should surprise no one that Victor Davion, the Davion-to-the-core Archon Prince of the illegitimate "Steiner-Davion" dynasty, has so shamefully neglected his Lyran subjects. We Lyrans cannot expect a Davion overlord to care for our well-being, and no loyal Steiner can ever regard a scion of the Davions as his natural ruler.

The vast, unwieldy arrangement imposed on the Lyran nation by the Federated Suns, prettified with the name "Federated Commonwealth" to make loyal Commonwealth citizens see the Steiner state as an equal partner in the FedCom empire, cannot possibly survive. Both history and common sense tell us so. Our beloved leaders of a generation ago tried and failed to accomplish an impossible task; their dream of a Steiner-Davion empire of peace was destined to fail. It is high time we let it. That much we owe to ourselves, the citizens of the free and sovereign Lyran nation.

## DETERMINING CRITICAL HITS TABLE

Dice Roll (2D6)	Effect
2-7	No Critical Hit
8-9	Roll 1 Critical Hit Location
10-11	Roll 2 Critical Hit Locations
12	Head/Limb Blown Off/Roll 3 Critical Hit Locations*

\*Roll 3 critical hit locations if the section struck is a torso.

### ◆ BattleMech Critical Hits

When an attacker inflicts a critical hit on a target, the defending player finds the damaged location on the Critical Hit Table on his BattleMech's record sheet, then rolls dice for each critical hit and marks off the damage inflicted on the Critical Hit Table.

**Head or Leg Hits:** If the critical hit is inflicted on the BattleMech's head or legs, roll 1D6, find the result on the Critical Hit Table, and mark off the damaged location. If the critical location rolled cannot take a critical hit or has already been destroyed by a critical hit, roll the die again.

**Torso or Arm Hits:** If the critical hit strikes the torso or arms of the BattleMech, the player rolls both dice. The result of the first die tells which half of the Critical Hit Table for that location is affected, and the result of the second die identifies the location hit. The Critical Hit Table for these locations is divided into two sets of 6 critical slots.

The result of the first die identifies which set of slots takes the hit. On a result of 1, 2, or 3, the shot hits a location in the first set of critical slots. On a result of 4, 5, or 6, the attack hits a location in the second set of critical slots.

The result of the second die roll identifies the critical slot that takes the hit. If the critical location rolled cannot take a critical hit or has already been destroyed by a critical hit, roll both dice again.

*A Wolfhound takes a critical hit to the left arm. The defending player rolls the first die with a result of 3. This means the critical hit will affect a location in the first half of the critical hit table for the left arm (labeled 1). The player rolls the second die with a result of 4, inflicting a critical hit on the 'Mech's hand actuator.*

Each weapon and other piece of equipment fills at least one critical hit location on the Critical Hit Table. If the player rolls damage for a location for which there is no component, or a location which is marked Endo Steel, CASE, or Ferro-Fibrous, or a location that has already taken a critical hit, he rolls again. If all of the possible critical hit locations in the damaged area have already taken critical hits in previous phases, the critical hit transfers to the next location per the Damage Transfer Diagram. When the last possible critical hit location in an area is destroyed, subsequent critical hits to that area in the same phase will not transfer. Critical hits to that area in later phases, however, will transfer normally. Center torso and head hits do not transfer.

Note that some weapons, double heat sinks, and other equipment take up multiple locations on the Critical Hit Table. A single critical hit disables any weapon or equipment except the engine, gyro, and sensors. (However, a heat sink critical hit destroys only the specific heat sink that is hit.) Critical hits on additional locations that the weapon, double heat sink, and so on occupy only increase the difficulty of repairing the damaged equipment (see **Repair Difficulty**, p. 95).

### BattleMech Critical Hit Effects

Each type of critical hit affects a 'Mech's performance in a specific way, as described below. The critical hit locations are arranged alphabetically by location; the

area of the 'Mech containing each location (head, leg, torso, arm, and weapons) is noted in parentheses.

◆ **Ammunition:** If a critical hit destroys a location carrying ammunition, the ammo explodes. The MechWarrior automatically takes 2 Damage Points through his neurohelmet as a result of the electronic systems exploding. The BattleMech takes damage to its internal structure.

When one ammo slot in a specific location explodes, all of the ammo in that location explodes. Calculate the total Damage Value of all ammo carried in that location and apply that total to the Internal Structure Diagram. If the location is not protected by CASE, any excess damage transfers to the internal structure of the next location. For locations mounted with CASE, apply the excess damage to the armor (the rear armor, for torso locations), then vent any remaining damage without further harm. See **Equipment**, p. 115.

A critical hit to an ammo location only explodes the ammo in that location. It explodes with a force equal to the ammo's Damage Value times the shots remaining. Missile ammo explodes with a force equal to the number of missiles remaining times their Damage Value. For example, 1 full ton of machine gun ammo explodes with a force of 400 points of damage (2 x 200), while 1 full ton of SRM-2 ammo explodes with a force of 200 points of damage (2 x 2 x 50).

**Arm Actuator (Arm):** This critical hit destroys the actuator in the BattleMech's upper or lower arm. Add a +1 modifier to the to-hit number for weapons firing from that arm and a +2 modifier for any punches.

These effects are cumulative: if both the upper and lower arm actuators are destroyed, modify the to-hit number for weapons fire by +2 and punches by +4.

**Arm Blown Off (Arm):** This critical hit occurs when the player rolls a result of 12 on the Determining Critical Hits Table when the location hit is an arm. It blows off the arm, destroying all weapons mounted there. The arm may be picked up and used as a club per the rules for **Clubs**, p. 46.

**Cockpit (Head):** A critical hit to the cockpit destroys that location, kills the MechWarrior, and puts the BattleMech out of commission for the game.

**Engine (Torso):** BattleMech engines have 3 points of shielding. Each critical hit to the engine location destroys 1 point of shielding. As points of shielding are destroyed, the amount of heat escaping from the BattleMech's fusion drive increases.

The first hit increases the 'Mech's heat build-up by 5 points per turn. The second hit results in 10 (total) points of added heat build-up per turn, and the third critical hit to this location shuts down the engine and puts the BattleMech out of commission for the rest of the game. Though XL engines take up additional locations (in the side

torsoes), 3 critical hits also shut down an XL engine.

◆ **Gyro (Torso):** The gyro is a BattleMech's most sensitive piece of machinery. It keeps the BattleMech upright and able to move. The gyro can survive only 1 critical hit; the second destroys it. Record these hits by marking off the gyro locations on the Critical Hit Table.

After the first critical hit to the gyro, the player must make a Piloting Skill Roll every time the damaged BattleMech runs or jumps, modifying the MechWarrior's Piloting Skill by +3. Make this roll at the end of each such move.

When a BattleMech's gyro is destroyed, it automatically falls and cannot stand up again. BattleMechs with a destroyed gyro may make weapons attacks per **Firing When Down**, p. 36, and may change their facing

by one hexside per turn provided they have at least 1 MP available.

◆ **Hand Actuator (Arm):** A critical hit to the hand actuator destroys the muscles controlling the BattleMech's wrist and hand. Add a +1 to-hit modifier to all punches made with this arm. This effect is cumulative with the effects of destroyed arm actuators.

**Head Blown Off (Head):** A hit blows off a BattleMech's head when the player rolls a result of 12 on the Determining Critical Hits Table when the location hit is the head. This critical hit destroys the BattleMech's head section, kills the MechWarrior, and puts the BattleMech out of commission for the rest of the game.

◆ **Heat Sinks:** One critical hit to a heat sink destroys the heat sink and reduces the BattleMech's ability to dissipate heat.

WOLFNET ARCHIVE FILE: 66799-STO-09/25/55

Excerpted from a suggested treatment for a holovid named *Dogs of War*—  
*The Unauthorized History of the Kell Hounds* (later released as *Heroes of the Inner Sphere*)

We could play up a few, specific aspects of this mercenary group as really effective audience hooks: their connection to the Steiner family and how this relationship and their wealth jump-started their careers; and the defection of one of their own to the enemy.

We start by touting the Kell Hounds as the premier mercenary unit in the Inner Sphere, second only to Wolf's Dragoons, repeat popular opinion about the unit (i.e., originally formed by Patrick and Morgan Kell, "two rich boys playing soldier,") then reveal their success despite perceived advantages. Next, make a big deal out of their natural talent, but downplay the fact that they knew enough to hire the best techs available.

We do a quick gloss over their long history of successful battles and campaigns, highlighting those that really show off their skill for complex planning and their tactical genius. Then we heavily dramatize the Hounds' troubles: the unit nearly disbanded after Morgan exiled himself to a monastery. Definitely stress the time when the unit rescued Melissa Steiner from a Draconis attack, but at the cost of Patrick Kell's life, then show Morgan's return to the unit as a result. During the Fourth Succession War, the unit was nearly destroyed by the elite Genyosha regiment from the Draconis Combine, and again was devastated by the Clans during the battle for Luthien. And best of all, Phelan Kell became a Khan of Clan Wolf.

That last incident alone will make great vid, depending on how we handle it. Did he betray the Inner Sphere by feeding military information to the Clans? Did his presence temper their assault and actually save lives? The real story may never become public knowledge.

The change of command between Morgan Kell and Lieutenant Colonel Daniel W. Allard will make a great closing scene.

For example, if a BattleMech is designed to dissipate 16 points of heat per turn, and 3 of its heat sinks have been destroyed, it can now only dissipate 13 points of heat per turn.

A double heat sink takes up more than one location on the Critical Hit Table, but it is destroyed by a single critical hit. Additional critical hits to a multi-location heat sink produce no further effects. Each double heat sink destroyed eliminates 2 points of heat dissipation ability.

◆ **Hip (Leg):** A hip critical hit freezes the affected leg in a straight position. After a hip critical hit, the BattleMech's Walking MP is cut in half (rounding up), ignoring any movement modifiers from previous critical hits on that leg. Add a +2 modifier to any subsequent Piloting Skill Rolls required, and make a Piloting Skill Roll every turn that the damaged BattleMech runs. The 'Mech cannot make Kick attacks.

A critical hit to the second hip reduces the BattleMech's Movement Points to 0 and adds another +2 modifier to its Piloting Skill Roll target number.

◆ **Jump Jet Exhaust Port (Leg/Torso):** When a jump jet exhaust port takes a critical hit, that jump jet can no longer deliver thrust. This decreases the distance the BattleMech can jump. The jump jet itself is not damaged; the designers provided protection from weapons fire for this equipment so as to prevent the devastating explosion that would occur if it were hit. The control system senses the damage to the exhaust port and shuts down the engine that uses that port. For each exhaust port hit, reduce the BattleMech's Jumping MP by 1.

◆ **Leg Actuator (Leg):** A critical hit to a leg actuator destroys the muscle (actuator) in the upper leg, lower leg, or foot. For each leg actuator damaged, reduce the BattleMech's Walking MP by 1 and add a +1 modifier to any subsequent Piloting Skill Roll.

◆ **Leg Blown Off (Leg):** This critical hit occurs when the player rolls a result of 12 on the Determining Critical Hits Table when the location hit is a leg. When a BattleMech's leg is blown off, the 'Mech automatically falls and takes normal falling damage, though it might be able to stand up again. See **Leg Destruction**, below. The leg may be picked up and used as a club, per the rules for **Clubs**, p. 46.

◆ **Leg Destruction (Leg):** When a BattleMech loses one leg, either through a critical hit or the destruction of the leg's internal structure, the BattleMech automatically falls down. In the next turn the BattleMech may attempt to stand on its remaining leg, but the pilot must add a +5 modifier to the Piloting Skill Roll plus any modifiers for other damage. If the BattleMech manages to stand, it has a Walking MP of 1. To account for the missing leg, add +5 to any Piloting Skill Roll made thereafter. The BattleMech may still jump (minus the power of the jump jets on the missing leg), but the pilot must make a Piloting Skill Roll each time the 'Mech lands.

◆ **Life Support (Head):** A BattleMech's life-support system protects its pilot from the machine's internal heat and keeps him alive on airless worlds and in hostile environments. In **BattleTech**, the life-support system's main function is to protect the pilot from the heat generated by the 'Mech's fusion reactor, movement, and weapons systems.

Any critical hit knocks this system out permanently and leaves the pilot vulnerable to increased heat. The MechWarrior takes 1 point of damage every turn that the BattleMech's internal heat ranges from 15–25, and 2 points of damage for every turn that its internal heat is above 25 on the Heat Scale.

◆ **Sensors (Head):** When a BattleMech takes a critical hit to the sensors, add a +2 modifier to the to-hit number every time the 'Mech fires its weapons. A second sensor hit makes it impossible for the BattleMech to fire any of its weapons.

◆ **Shoulder (Arm):** A critical hit to this location freezes the shoulder joint. The 'Mech may not punch with that arm. Add a +4 modifier to the to-hit number for all attacks made with weapons mounted on that arm. After a shoulder critical hit, ignore all other weapons fire modifiers from arm critical hits; the total to-hit modifier for weapons and actions involving the damaged shoulder is +4.

**Weapons:** Most weapons systems are surprisingly delicate, and so a single critical hit destroys a weapon. Though some weapons systems occupy more than one location on the Critical Hit Table, the first critical hit destroys the weapon. Additional critical hits to a multi-location weapon have no further effect, other than to make the equipment more difficult to repair. For example, a particle projector cannon mounted on a BattleMech's arm fills 3 critical slots. However, the cannon is destroyed as soon as one of its three critical locations takes a hit.

## ◆ DESTROYING A UNIT

Under the specific conditions described below, a unit must be considered destroyed. Note that a "destroyed" unit may not be actually physically destroyed. It simply is rendered tactically useless and referred to as a "mission kill." Such units are out of the game, but may be repaired later if the rules for **Scavenging and Repair**, p. 94, are being used.

## BattleMechs

A BattleMech is considered destroyed and out of the game if its MechWarrior dies or the BattleMech suffers 3 engine hits. Note that the destruction of the head, cockpit, or center torso has the same effect and renders a BattleMech destroyed.

## Vehicles

A vehicle is considered destroyed and out of the game when all of its internal structure boxes in one section are marked off, or when its Critical Hit Table indicates that it is destroyed.

## Infantry

Unarmored infantry platoons are considered destroyed when all boxes in the unit row have been marked off. Battle-armored units are destroyed when all boxes in each unit member's row have been marked off.

## ◆ AMMUNITION EXPENDITURES

BattleMechs carry a limited amount of ammunition for missile launchers, machine guns, autocannons, and other ballistic and missile weapons. The record sheet for each BattleMech indicates the available ammo bins and number of shots for each weapon on the Critical Hit Table. The player should keep a tally on the Critical Hit Table, making a hatch mark next to the appropriate ammo bin every time he fires the corresponding weapon. When the number of marks equals the amount of ammo carried in that location, that bin is empty. If no other bins in the BattleMech carry that type of ammo, the weapon is out of ammunition and cannot be fired for the rest of the game.

## PHYSICAL ATTACKS

BattleMechs can make six different types of physical attacks: punching, clubbing, pushing, kicking, charging, and death from above. Vehicles' only physical attack is a charge (ram). In order to make a physical attack, the unit must be

adjacent to its target and the target must be within the forward firing arc (see **Punching, Charging, and Death from Above** for exceptions).

Each type of physical attack has a unique base to-hit number, modified by terrain, movement of both the attacking unit and its target, and the attacker's current critical damage to its arms and/or legs. The damage location for physical attacks is determined using specific Hit Location Tables, but is recorded in the same way as damage from weapons fire.

In many cases, the player calculates damage inflicted by physical attacks by dividing the tonnage of the attacking BattleMech by a given number, rounding fractions up.

A BattleMech may use only one form of physical attack per turn. For example, BattleMechs may not punch and kick in the same turn.

## ◆ PUNCHING

In a single turn, a BattleMech can either deliver a punch using its arm or fire the weapons on that arm, but may not do both. A BattleMech does not need hands (or hand actuators) to punch. It may punch with one or both arms. Weapons mounted in the torso, legs, or head may be fired in the same turn as a punching attack is made without affecting the punch.

A BattleMech cannot make a punching attack using a shoulder that has suffered critical damage, and any arm actuator damage on the punching arm makes success more difficult. All punching attacks must be made against targets in the attacking BattleMech's forward or side firing arcs. If the target is in the right or left arc, then only the right or left arm, respectively, may punch. If the target is in the forward arc, then both arms may be used in the punching attack.

The Base To-Hit Number for a punch is 4, modified by movement and terrain just as for weapons fire; by +2 for each arm actuator destroyed or not present; and by +1 if the hand actuator has been destroyed or is not present. Note that BattleMechs not equipped with a hand on the punching arm must add the +1 modifier for not having a hand. Likewise, BattleMechs that do not come equipped with a lower arm actuator on the punching arm must add a +2 modifier to the to-hit number.

The player makes a separate to-hit roll for each arm making a punching attack. The punch from each arm has a Damage Value of 1 for every 10 tons (or fraction of 10 tons) that the attacker weighs. Reduce the damage by half for each arm actuator damaged or not present, with these effects being cumulative. In other words, if both arm actuators are missing, reduce the damage to one-quarter of its original value (fractions rounded down). Determine the damage location for BattleMech targets by rolling 1D6 and consulting the BattleMech Punch Location Table.

BattleMechs cannot make punching attacks against ground vehicles or infantry unless the BattleMech is one elevation level lower than normal because it is prone, on lower terrain, or standing in Depth 1 water.

WOLFNET ARCHIVE FILE: 98342-KB6-44/78/1

**Excerpted from an intercepted personal communication between two unidentified Jade Falcon commanders**

Bah! Any fool can see that the Wolves only succeeded in taking control of the largest number of systems because they fought only the weakest, most cowardly members of all the dishonorable Inner Sphere realms. Free Rasalhague Republic? I spit on any collaboration of strag dogs that would so boldly display its lack of strength in its very name.

Those freebirth curs within our own ranks who dare to suggest that Wolf conquered so many worlds through—and they use these very words—“their commanders’ uncanny military prowess, their leaders’ constant efforts to understand our enemy’s tactics, and their grudging respect for the Inner Sphere forces” only reveal their own traitorous minds to those of us strong enough to uphold Kerensky’s true vision.

The most damning evidence of their corrupted will lies in the Inner Sphere trash they have elected to Junior Khan, the freebirth named Phelan. Spawned in the womb of one of the Inner Sphere’s greatest mercenary units (a prime example of the depths to which those whom our beloved Kerensky quite rightly left behind have sunk), Clan Wolf allowed this filth to join the warriors’ ranks, compete for and earn the Ward Bloodname, and then dishonored our founder’s memory by giving him the second highest position in the Clan. I vow death and dishonor for Clan Wolf, who nursemaid all their bondsmen this way!

For now, we must listen to these Wardens mewling about protecting the Inner Sphere, saving these unworthy realms from outside aggression. I say we must save the wretched Inner Sphere freebirths from themselves. We must continue our efforts to end this unworthy truce and strike at Terra. We must establish the new Star League of Kerensky’s pure vision, and I know there are those in Clan Wolf willing to help.

## BATTLEMECH PUNCH LOCATION TABLE

Dice Roll Result (1D6)	Left Side	Front/Rear	Right Side
1	Left Torso	Left Arm	Right Torso
2	Left Torso	Left Torso	Right Torso
3	Center Torso	Center Torso	Center Torso
4	Left Arm	Right Torso	Right Arm
5	Left Arm	Right Arm	Right Arm
6	Head	Head	Head

*An Archer with a damaged upper arm actuator punches a Warhammer on the right side with one fist. Because the Archer is damaged, the player adds a to-hit modifier of +2 and reduces the normal damage by half. The Modified To-Hit Number is a 6 (4 + 2); the player rolls an 8 and hits the target. The Archer weighs 70 tons, and so its punch has a normal Damage Value of 7 (70 divided by 10), but this is reduced to 3 because of the damaged actuator. The attacking player rolls a 3, which means the attack hits the target’s center torso. The player with the Warhammer records 3 points of damage by crossing 3 boxes off the Armor Diagram on his record sheet.*

### ◆ CLUBBING

Whenever an attack blows off a leg or arm of a BattleMech, the limb remains lying in the hex where the BattleMech took the damage. The BattleMech that lost the limb, and other BattleMechs that later occupy that hex, may pick up the arm or leg and use it as a giant club. A BattleMech may not fire weapons or make physical attacks during the turn that it picks up a club.

Other objects may also be used as clubs. If the BattleMech is in a wooded hex, it may uproot a tree and use it as a club. Uprooted trees may be used for only 1 successful club attack. Girders from rubbled Medium, Heavy, or Hardened Buildings may also be used as clubs. To search the rubble for a suitable girder, the player must roll 2D6 during the Weapon Attack Phase of a turn. A result of 7+ is needed to find a girder in a rubbled Medium Building, a 6+ is needed for a rubbled Heavy Building, and a 5+ is needed to find a girder in a rubbled Hardened Building.

To attack another unit with a club, all the BattleMech’s shoulders and hand actuators must be in working order and no arm-mounted weapons can have been fired in that same turn, though weapons mounted in the torso, legs, and head may be fired. The target must be in the forward firing arc.

The unit making the attack with a club makes a two-handed swing using a Base To-Hit Number of 4 modified by the normal to-hit modifiers for terrain and movement.

If any of the BattleMech’s upper or lower arm actuators have been destroyed or are not present, add a punch modifier of +2 per missing arm actuator. A BattleMech attacking with a club does 1 point of damage for every 5 tons that the BattleMech weighs. Roll normally on the BattleMech Hit Location Table. Clubs may be used against any type of unit, but units that make a clubbing attack against infantry add an additional +3 to-hit modifier.

### ◆ Hatchets

Some BattleMechs come equipped with hatchets. Like other weapons, hatchets have weight and take up one or more locations on the Arm section of the Critical Hit Table. To use the hatchet, a BattleMech must have a functioning hand actuator in the arm in which the hatchet is mounted.

A BattleMech uses a hatchet to make physical attacks per the standard clubbing attack rules, but need use only one arm for the attack, rather than two. Though a BattleMech may mount two hatchets, one in each arm, the pilot can make only one hatchet attack per turn. The pilot may fire weapons mounted on the arm not carrying the attacking hatchet in the Weapon Attack Phase.

Hits on a hatchet critical location represent damage to the shaft of the weapon. If a hatchet critical location takes a hit, the weapon is no longer functional.

## PUSHING

A BattleMech uses both arms to make a pushing attack against its target. No arm-mounted weapons can be fired in the turn that a BattleMech makes a pushing attack. All torso-, leg-, and head-mounted weapons may be fired normally. Pushing attacks can be made against targets in the forward arc only.

The Base To-Hit Number for a push is 4, modified as usual for movement and terrain, and by +2 for each shoulder actuator destroyed. A successful push does not automatically damage the target. Instead, it moves the defending BattleMech into the adjacent hex in the direction that it is being pushed by the attacker. If the push is successful, the attacking BattleMech advances into the hex formerly occupied by its target. At the same time, the defender must make a successful Piloting Skill Roll or fall. Vehicles and infantry may not be pushed.

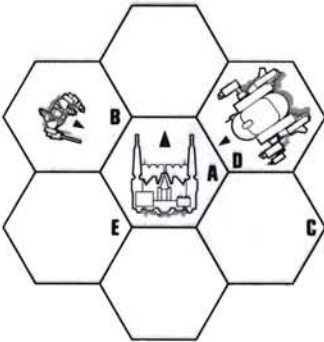

*If the Warhammer in Hex A is successfully pushed by the BattleMech in Hex B, it moves into Hex C. If the Warhammer in Hex A is successfully pushed by a BattleMech in Hex D, the Warhammer will be forced into Hex E. In both cases, the pilot of the Warhammer must make a Piloting Skill Roll to remain standing, and its attacker will advance into Hex A.*

## KICKING

A BattleMech may only make a kicking attack with one leg per turn. No weapons mounted on that leg can fire in the turn in which the 'Mech kicks. To make a kicking attack, both hips of the attacking 'Mech must be undamaged, and the BattleMech's target must be in one of the 3 forward-arc hexes. The BattleMech may kick vehicles in its forward arc, or kick (stomp) a vehicle or infantry unit in the hex it occupies.

A player who declares that his BattleMech will make a kicking attack uses a Base To-Hit Number of 3, modified as usual by movement and terrain. Kicks have a Damage Value of 1 point for every 5 tons of the attacking BattleMech's weight. For example, a *Warhammer's* kick would inflict 14 Damage Points. Reduce this damage by half for each leg actuator damaged (on either leg), with these effects being cumulative. For example, if two leg actuators are missing, reduce the damage to one-quarter its original value, rounding fractions down. Determine the location of the damage by rolling 1D6 and consulting the BattleMech Kick Location Table.

A BattleMech that has been successfully kicked must make a Piloting Skill Roll. If the attacking BattleMech misses its kick, it must also make a Piloting Skill Roll.

When making kicking attacks, use all standard to-hit modifiers, including -2 for attacks against prone BattleMechs from adjacent hexes. To determine the location of kicking damage to a prone BattleMech, use the BattleMech Hit Location Table (rather than the BattleMech Kick Location Table), using the hex side that the kick originates from as the attack direction.

BattleMechs can kick vehicles and infantry units, but use a +3 to-hit modifier for such an attack against infantry—infantry units tend to scurry out of the way when BattleMechs get too close, making them harder to hit. The side on which a vehicle takes damage is determined randomly if the BattleMech is attacking from the same hex.

**BATTLEMECH  
KICK LOCATION TABLE**

Die Roll Result	Left Side	Front/Rear	Right Side
1-3	Left Leg	Right Leg	Right Leg
4-6	Left Leg	Left Leg	Right Leg

## CHARGING

All BattleMechs and vehicles may make charging attacks. In order for a BattleMech to charge, both legs must be functioning. The unit may not have moved backward in the Movement Phase of the turn. The target must be in the hex directly in front of the charging unit at the beginning of the Physical Attack Phase; in other words, the charging unit must be able to enter the target unit's hex without turning. The charging unit may not make any weapon attacks in the same turn.

A BattleMech may not charge vehicles or infantry.

Charging attacks must be declared during the Movement Phase, but like all other physical attacks, they are resolved during the Physical Attack Phase. This means that the charging unit can only attack units that have finished their movement.

The charging unit must spend Movement Points to enter the target hex, whether or not the charge is successful. If a unit does not have enough Movement Points left over from its

WOLFNET ARCHIVE FILE: 88753-PL9-33/1/8

From *History of the Combine*, a recently published Combine textbook

Founded in 2319 by Shiro Kurita, the Draconis Combine is among the most powerful and feared of the Successor States. To ensure stability, our wise founder patterned Combine society after that of feudal Japan. Embracing bushido, "the way of the warrior," Draconis MechWarriors value their own honor and that of the Combine above all others. Bushido has been a key factor in the Combine's continued survival over the chaotic, war-torn centuries of its existence.

In this past century, the Draconis Combine has undergone many significant changes. During the Fourth Succession War, our military proved no match for the invading forces of the Lyran Commonwealth, something that had never before happened in the history of the Succession Wars. Four years after the end of the war, the Principality of Rasalhague declared its independence from the Combine, forming the Free Rasalhague Republic. Many viewed this as a mistake; but Theodore Kurita, then Director of Military Affairs, pointed out that Rasalhague served as a useful buffer state on the Combine's border with the Lyran half of the Federated Commonwealth. Therefore, the Combine could concentrate its military forces elsewhere.

During the Clan invasion, the rejuvenated Combine military proved its effectiveness twice by claiming the Inner Sphere's first victory over the Clans on Wolcott, and by successfully defending our capital world of Luthien from a massive Clan attack.

Since the Truce of Tukayyid, our wise Coordinator Theodore Kurita has ignored the petty squabbings of the other Successor States, including the recent break-up of the Federated Commonwealth. Instead, he is taking steps to eliminate the greatest threat to the Inner Sphere: the Clans. To this end, he has set a covert plan in motion that may eventually locate the Clan homeworlds, so that we may take the fight to the invaders' doorstep.

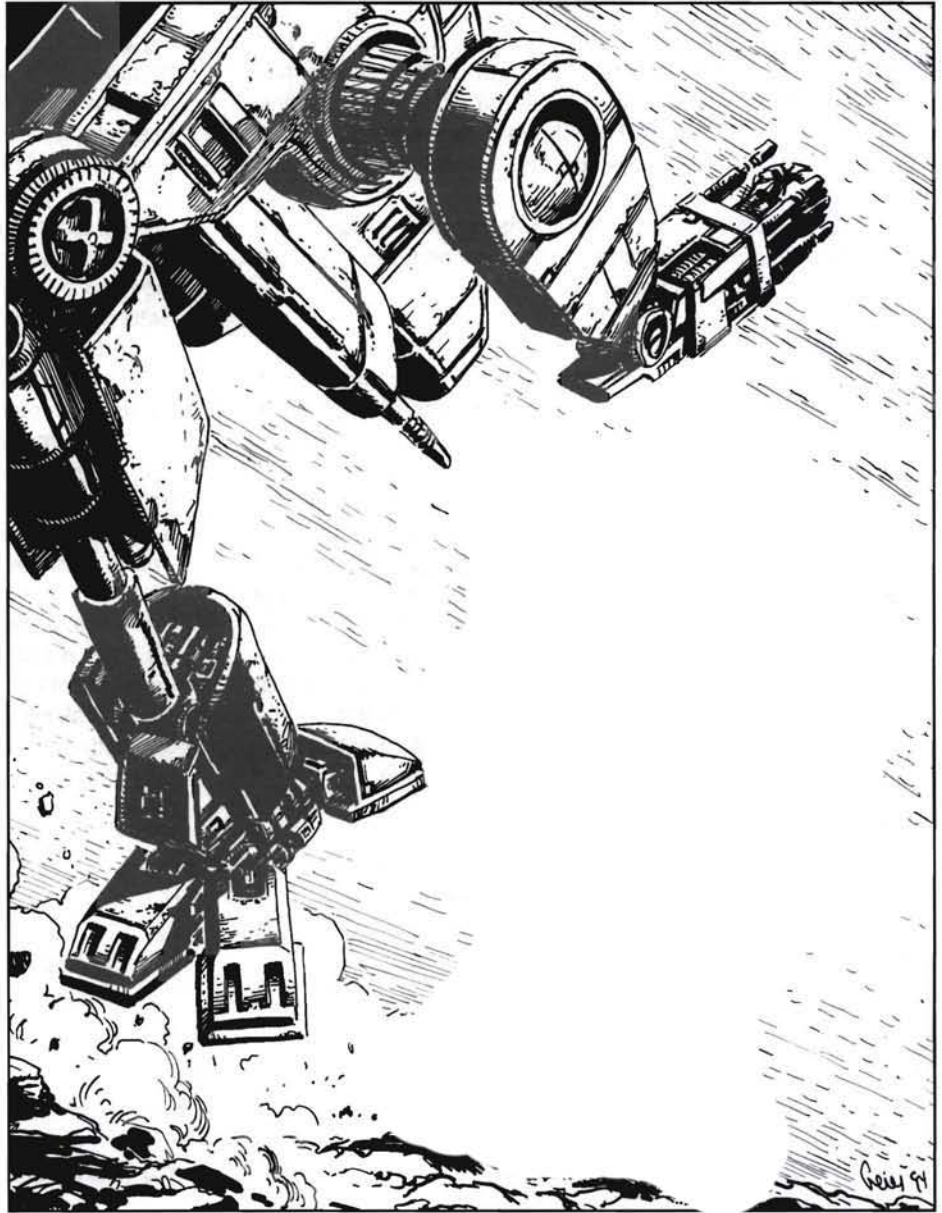

Movement Phase to enter the target hex, it may not make a charging attack. In addition, if the target occupies terrain that the attacking unit is restricted from entering, the unit may not charge.

The Base To-Hit Number for a charge is 5, modified as usual for both the attackers and defender's movement. Whenever one BattleMech charges another, compare the MechWarriors' Piloting Skills and use the difference between the two skill levels as a Piloting Skill modifier to the to-hit roll. If the defending MechWarrior's skill level is lower, subtract the modifier from the to-hit number. If the attacker's Piloting Skill level is lower, add the modifier to the to-hit number.

*A Black Hawk with a Piloting Skill level of 4 is charging an Archer with a Piloting Skill level of 5. Since the attacking MechWarrior's skill level is lower, the difference between the two is subtracted from the to-hit number, providing a -1 to-hit modifier. If the skill levels of the pilots were reversed, the attack would suffer a +1 to-hit modifier.*



# BATTLETECH

WOLFNET ARCHIVE FILE: 01443-TB2-29/1/54

We compiled the following images from transmissions intercepted on the borders of the Clan occupation zones. When viewed as a group, they offer an excellent cross section of modern battlefield technology—often referred to as *BattleTech*.



A Clan Wolf *Vulture* advances on enemy lines firing its large pulse lasers.



*A Union class DropShip disembarks from a JumpShip and begins its trip insystem.*

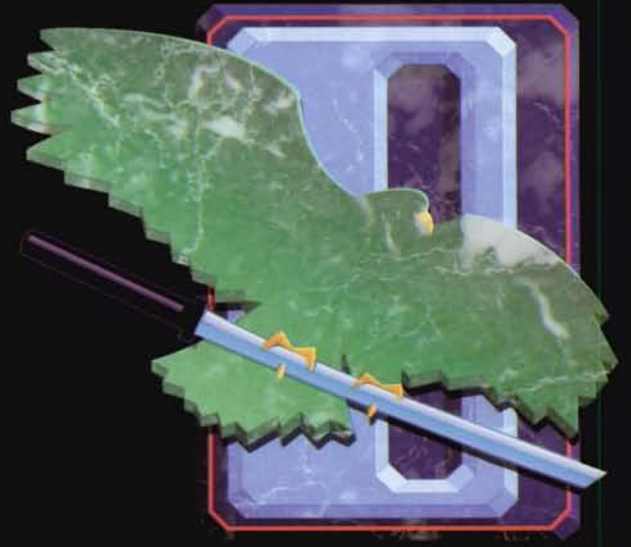

Jade Falcon Elementals fight from the cover of a fallen *Mauler*.



*A Mad Cat unleashes a deadly barrage of weapons fire.*

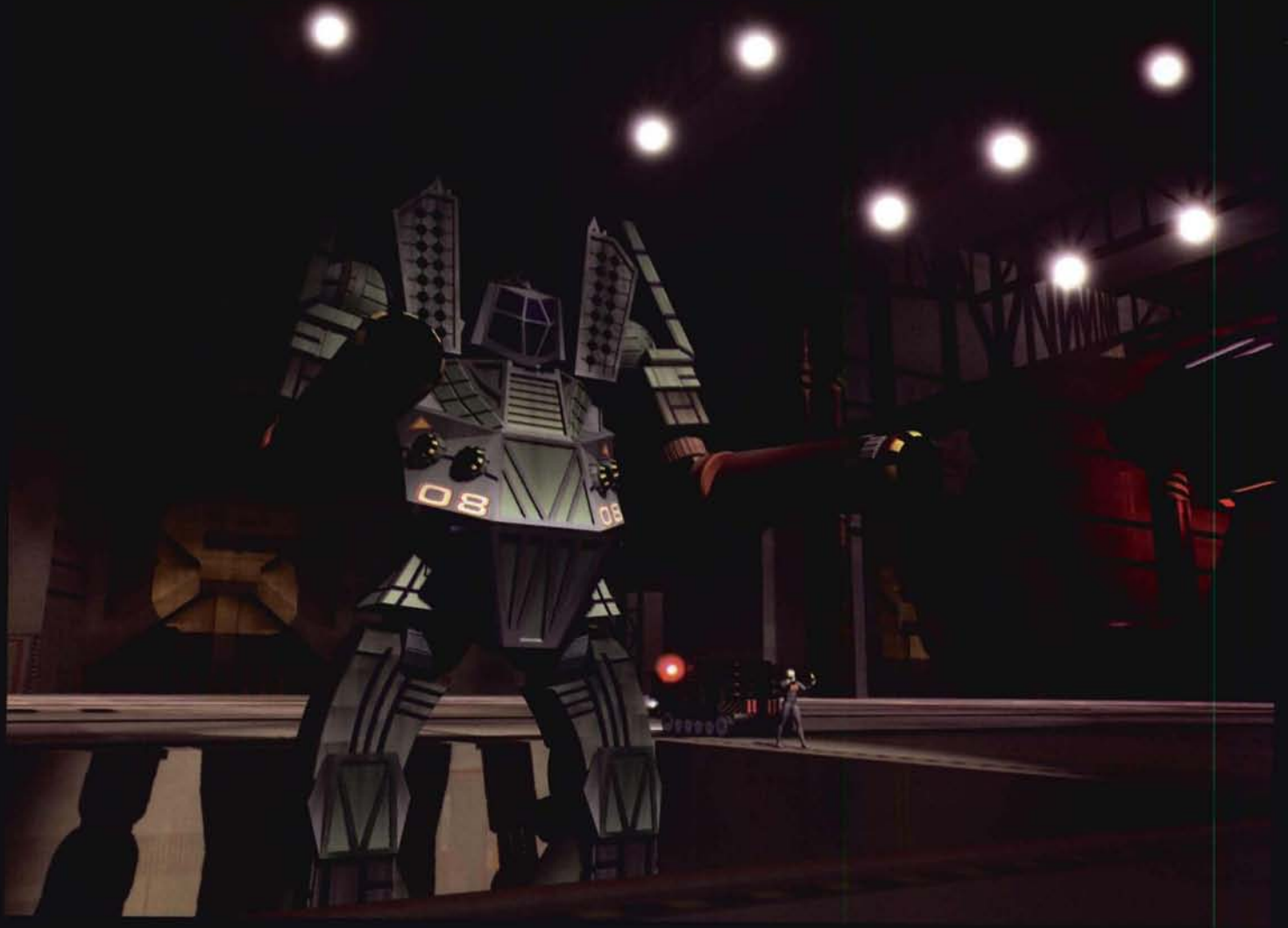

A DCMS ground crew prepares a *Mauler* assault 'Mech for battle.

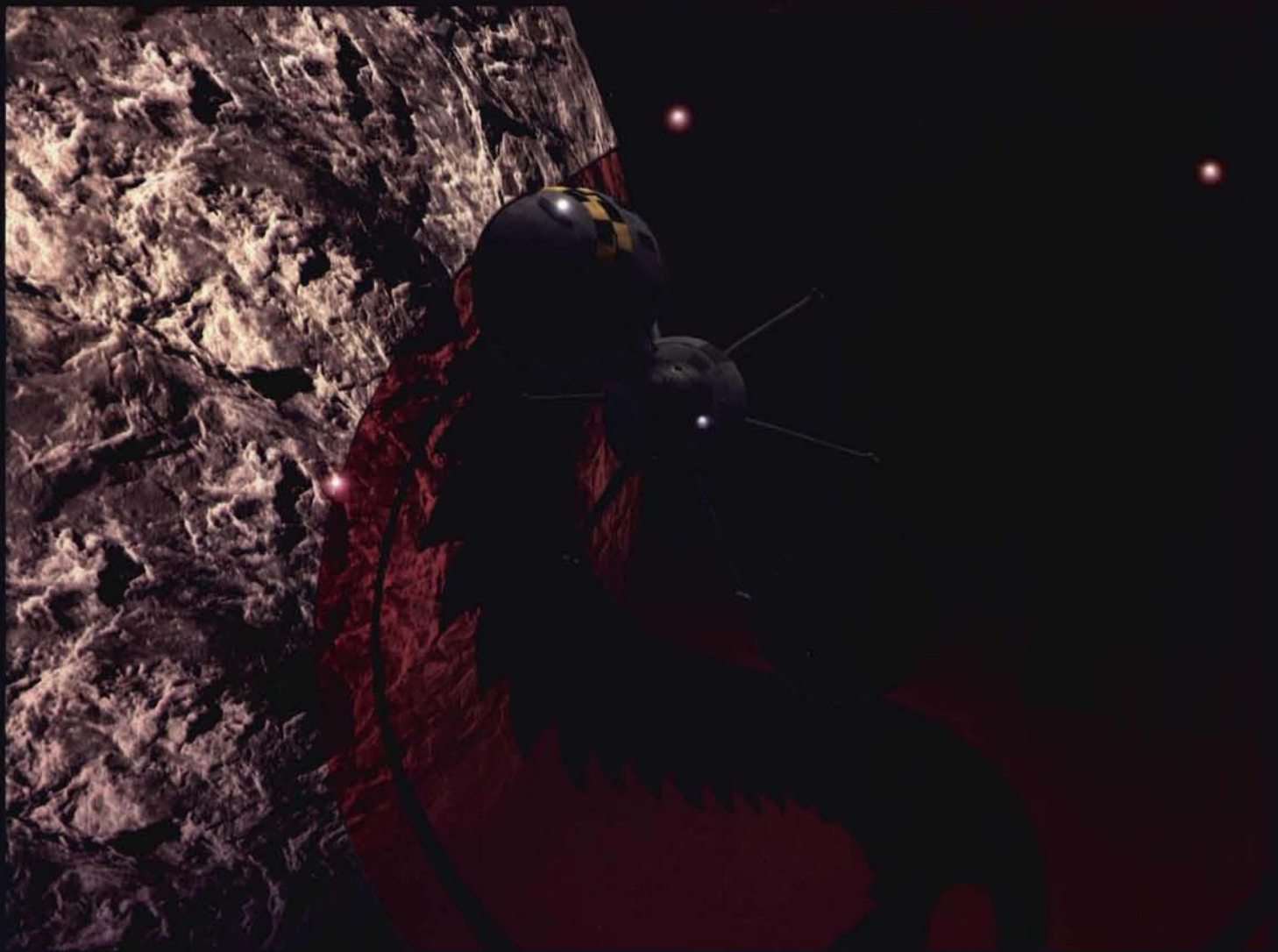

ComStar surveillance footage of a Draconis Combine *Merchant* class JumpShip.

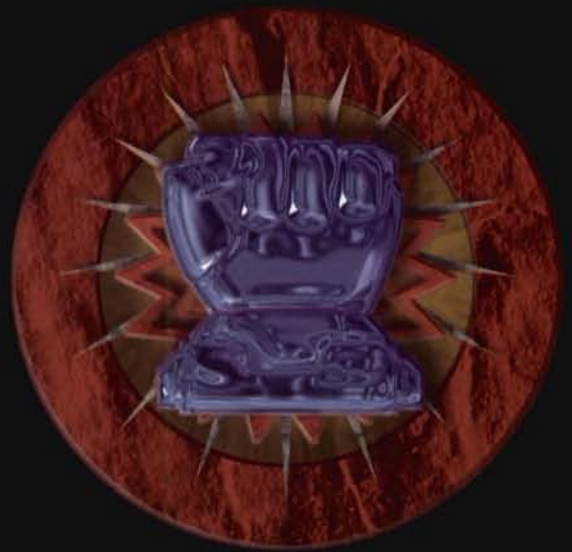

Federated *Axmen* emerge from a supply base accompanied by J-27 transports.  
(Inset) A well-placed hit on an *Axman* triggers an ammunition explosion.

# COMBAT

## ◆ Damage

Both units take damage from the collision. The defender takes 1 point of damage for every 10 tons that the charging unit weighs, multiplied by the number of hexes moved by the attacker in the Movement Phase. The charging unit takes 1 point of damage for every 10 tons the target weighs. Round any fractions up.

Group the damage resulting from charging attacks into 5-point clusters. The attacking player rolls once on the appropriate Hit Location Table for each cluster.

If the attacker is charging a prone BattleMech, the defender takes damage on the appropriate column of the BattleMech Hit Location Table, but the damage to the attacker is taken on the BattleMech Kick Location Table.

If a unit charges a target that is in a building, the building absorbs damage as normal (see **Combat Effects in Buildings**, p. 58). The charging pilot also must make a Piloting Skill Roll modified by +3 in addition to the building modifier to avoid taking damage from entering the building (see **Movement Effects in Buildings**, p. 57). If the target unit must pass through walls as a result of a successful charge (the unit is pushed out of its position), the target pilot must make a Piloting Skill Roll modified by +3.

*An Archer moves 4 hexes and declares a charging attack against another BattleMech. If the charging attack is successful, the defender takes 28 points of damage (7 for the Archer's tonnage multiplied by 4 for the number of hexes it moved).*

## Location after Attack

If the charging attack succeeds, the defending unit is forced to move just as if it had been pushed, and the attacker advances into the defender's hex. If the attacker misses the target, the player places the attacking unit in the right or left hex of its forward arc.

## Falls

After any successful charging attack, both the attacking and defending BattleMechs must make Piloting Skill Rolls modified by +2. A failed Piloting Skill Roll means that the BattleMech falls in the hex it currently occupies and takes additional damage from the fall.

## DEATH FROM ABOVE

BattleMechs can make a charging attack while jumping, resulting in a physical attack that is damaging to both the attacking BattleMech and its target. In effect, the charging BattleMech crashes into the target from 2 elevation levels above the target unit, using its feet and weight to inflict damage to the target's upper torso, arms, and head. The charging BattleMech risks taking damage to its legs, which are not designed for the enormous stress created by this attack. Finally, both BattleMechs will almost certainly fall.

This type of charge may actually cause less damage than a standard charging attack, but the damage is concentrated on

the upper part of the target BattleMech. In fact, this attack has a 1 in 6 chance for a head hit, which is very high. Death from above attacks may also be made against vehicles and infantry. Resolve successful death from above attacks against a vehicle on the Front column of that vehicle's Hit Location Table. For death from above attacks against infantry targets, add an additional +3 to-hit modifier.

A BattleMech making a death from above attack is immune to physical attacks, but it may be the target of weapon attacks. See **Weapon Attack Phase**, below.

A BattleMech may only make one death from above attack against one target per turn.

## ◆ Weapon Attack Phase

Units make the death from above attack after the Weapon Attack Phase of the turn. For purposes of firing on the attacking unit, during the Weapon Attack Phase the attacking unit is considered to be adjacent to the target hex along the path that the attacking unit will travel during the jump and facing the target hex. It can be fired on as normal during the Weapon Attack Phase. The jumping unit does not receive the benefit of any terrain modifiers when being shot at and every other unit on the board has LOS to the attacking unit. The jumping unit cannot make any weapon attacks during this turn.

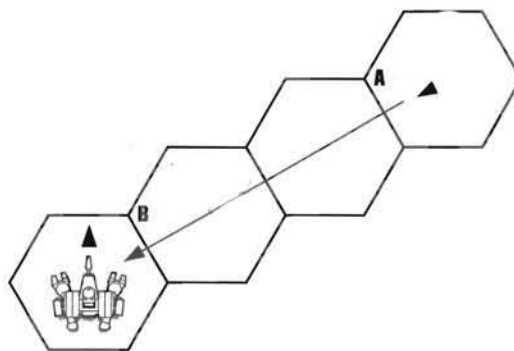

*A Stinger is making a death from above attack from Hex A on a Locust. The Stinger's path during the jump is as shown in the illustration. During the Weapon Attack Phase, the Stinger is considered to be in Hex B. The Locust may fire against the Stinger's Front side with any weapons that it can bring to bear at a Range of 1.*

If the attacking BattleMech takes damage during the Weapon Attack Phase that forces the pilot to make a Piloting Skill Roll, the player should roll as normal. A failed roll means that the attack automatically misses. Resolve the attacker's fall and ending location per the rules below.

A BattleMech does not count as stacked in a hex while executing a death from above attack until it completes its attack. As soon as it lands, normal stacking limits apply (see **Stacking**, p. 24).

WOLFNET ARCHIVE FILE: 33564-VT7-22/6/5

From the opening pages of *Wolf Tales #1*, a popular comic book in the Inner Sphere

Wolf's Dragoons. The most famous mercenary unit in the Inner Sphere. They appeared from unknown regions beyond the Periphery in 3005, and for fifty years fought for noble causes across known space. On their freehold of Outreach, given to them by Prince Hanse Davion in return for their service during the Fourth Succession War, the Dragoons have recreated the "Mercenary's Star" of olden times. On Outreach, the Inner Sphere's noble outlaws survive and thrive, to fight for the freedom of others throughout the Successor States.

Some say Wolf's Dragoons hail from the pirate kingdoms of the Periphery. Some even say that they are members of the Clans, so-called "freebirth" warriors sent to the Inner Sphere as spies, who later rebelled against their "truebirth" masters. But no matter what their origins, they are heroes.

In the early days of the Clan War, the Dragoons rallied the terrified House Lords into a united front against the rapacious enemy. When the Smoke Jaguars and Nova Cats struck their death-blow at the Draconis Combine's capital world of Luthien, the Dragoons fought alongside the Kurita House units that had once despised them as "mercenary scum," saving the Combine from destruction. At the end of the Clan War, the Dragoons returned to their freehold of Outreach, taking Clan prisoners of war with them.

That act almost proved their undoing.

The captured Clansmen tried to oust Colonel Jaime Wolf and take control of the Dragoons, sparking a civil war on Outreach. But like a sword forged by the hottest fire, the Dragoons survived the challenge and grew stronger. Under the command of General Maeve Wolf, Jaime Wolf's handpicked successor, the Dragoons and the Mercenary's Star remain a power to be reckoned with.

This is the story of their triumph.

## Base To-Hit Number

The Base To-Hit Number for a death from above attack is 5, modified for the jumping movement of the attacker and the normal movement of the target, but not for terrain.

If the attack is successful, both BattleMechs take damage as determined below. If the attack misses, the jumping BattleMech crashes to the ground and takes damage (see **Damage to Attacker**, below).

## ◆ Damage to Target

To determine damage to the target from a death from above attack, divide the weight of the attacking BattleMech by 10 and multiply the result by 3. For example, a *Spider* with a weight of 30 tons inflicts 9 points of damage to the upper part of the target.

Distribute this damage as though it were a series of 5-point punches. Group the damage into 5-point clusters. Determine the hexside hit as though the attack had come from the attacking BattleMech's starting hex, then determine the hit location of each cluster by rolling 1D6 and consulting the BattleMech Punch Location Table, p. 46. Record damage as usual.

Prone BattleMech targets take damage to their Rear sides, using the normal BattleMech Hit Location Table.

Vehicle targets take damage to their Front sides.

## Damage to Attacker

The attacker takes damage from a successful attack on its legs as though the attacker had fallen 1 elevation level. To determine the amount of damage, divide the attacker's weight by 5, rounding up. Divide the result into 5-point clusters, then roll 1D6 for each cluster and consult the Front column of the BattleMech Kick Location Table to find the location hit.

## Location after Attack

At the end of a death from above attack, the attacker lands in the target's hex. If the death from above attack is successful, the target is pushed 1 hex in the direction opposite the attack. If the attack fails, the target chooses an adjacent hex and moves to it, even if immobile or prone. This motion might result in **Accidental Falls from Above** or a **Domino Effect**, p. 51.

## ◆ Falls

A successful death from above attack may cause both BattleMechs to fall. Both MechWarriors must make Piloting Skill Rolls, the target adding a +2 modifier and the attacker adding a +4 modifier. If either unit fails this roll, the unit takes damage as from a 0-level fall.

On an unsuccessful attack, the attacker automatically falls, taking damage as though the 'Mech had fallen 2 elevation levels. To determine the amount of damage, divide the attacker's weight by 10 and multiply the result by 3. Divide the total damage into 5-point clusters, then roll 2D6 for each cluster and determine hit locations as though the BattleMech had landed on its back.

## DIFFERENT ELEVATIONS

The rules for punching, clubbing, kicking, and charging attacks assume that the opposing BattleMechs are at the same elevation. Most physical attacks against vehicles occur only if the vehicle is being attacked by a unit at the same elevation. See **Vehicles**, p. 65, for exceptions.

A BattleMech may make a physical attack against another BattleMech only if both 'Mechs are within 1 elevation level of one another. The Different Elevations Table shows which types of physical attacks can be made in various situations. Note that players must use different Hit Location Tables to determine the location of damage from punching, clubbing, or kicking attacks against an opponent on various levels.

## DIFFERENT ELEVATIONS TABLE

Target is:	Allowed Physical Attack
1 level higher	Charge, Punch (use Kick table), or Club (use Kick table)
1 level lower	Charge, Kick (use Punch table), or Club (use Punch table)

**Note:** A death from above attack can always be made if the BattleMech has the necessary Jumping MP.

## ◆ PHYSICAL ATTACKS BY PRONE BATTLEMECHS

Prone BattleMechs can make only two types of physical attacks: thrashing attacks against infantry and punches against ground vehicles in the same hex. Vehicles take punch damage from prone attacks against their Front sides.

When a downed BattleMech and an infantry unit (armored or unarmored) occupy the same hex, the BattleMech may make a thrashing attack by wildly waving its arms and legs in hopes of making contact with the infantry. The attack can only be made in Clear or Paved terrain and is automatically successful. This attack inflicts damage on the infantry equal to the BattleMech's tonnage divided by 3. If a BattleMech makes a thrashing attack, it cannot make any other attack in that turn, and the MechWarrior must make a Piloting Skill Roll to prevent damage to his BattleMech. If the pilot fails this roll, the BattleMech suffers normal falling damage.

## ACCIDENTAL FALLS FROM ABOVE

A BattleMech that falls unintentionally takes and inflicts damage according to the following rules. When a BattleMech accidentally falls 2 levels or more into a hex occupied by another BattleMech, make a to-hit roll with a Base To-Hit Number of 7, modified by target movement and terrain. When a BattleMech accidentally falls 1 level or less into a hex occupied by another BattleMech, treat it as if resulting in a **Domino Effect**, below. Do not make a to-hit roll if the BattleMech falls into a hex occupied by an infantry or vehicle unit; accidental falls automatically miss infantry, and vehicles are automatically hit by an accidental fall and missed by the Domino Effect.

A BattleMech may not intentionally "accidentally" fall from above for any reason.

### Falling BattleMech Hits Target

If the to-hit roll is successful (or if the target unit is a vehicle), treat the accidental fall as a successful death from above attack, with the following exceptions. If the "target" unit is a BattleMech, the falling 'Mech takes damage to its upper body. If there is more than one non-infantry unit in the target hex (friend or foe), determine randomly which will be the target unit.

Determine the amount of damage inflicted on the target unit by dividing the weight of the falling BattleMech by 10. Divide the damage into 5-point clusters, then roll 1D6 for each cluster and consult the BattleMech Punch Location Table. Determine damage to the falling ("attacking") BattleMech as normal for a fall, with the BattleMech falling on its Rear side. (Once it has fallen, a BattleMech that fell accidentally is assumed to be prone on its Front, as with all other prone BattleMechs.)

### Falling BattleMech Misses Target

If the to-hit roll is not successful, the falling BattleMech lands in an adjacent hex, as close to the hex that it fell from as possible, and takes the standard damage from falling. No other units take damage.

## ◆ DOMINO EFFECT

If a BattleMech accidentally falls 1 level or less or is forced into a hex occupied by another BattleMech, the second BattleMech is normally forced out of the hex in the direction of the push. The second BattleMech can avoid this by moving out of the hex, as long as it is neither facing the first BattleMech nor facing directly away from it.

WOLFNET ARCHIVE FILE: 34668-TV6-55/6/1

## Intercepted report from a Combine agent on Wolcott

TO: His Excellency, Coordinator Theodore Kurita  
 FROM: ISF Agent Shin Masura, Wolcott Command  
 RE: Clan Smoke Jaguar

I regret to inform Your Excellency that our Smoke Jaguar foes appear to have successfully consolidated control over the large number of Combine worlds they conquered during the invasion. Perhaps we should not find this surprising—to be part of the original Clan invasion force, Clan Smoke Jaguar had to exhibit considerable military prowess. Despite such defeats as we handed them on Wolcott and Luthien, the assistance later rendered them by Clan Nova Cat appears to be the result of politics, not dire need.

Their methods for enforcing control over captured planets are brutal, as might be expected from the only Clan to raze a city from orbit with the fearsome power of a capital WarShip. May the destruction of Edo on the world of Turtle Bay live long in infamy! But I digress—Your Excellency will wish to know more of the situation on Wolcott.

Though the Smoke Jaguars have surrounded the world, they still regard themselves as honor-bound to their promise not to set foot on it. As Your Excellency knows, planetary blockades are notoriously difficult to enforce; if we use the most skilled of our JumpShip pilots to find the constantly shifting pirate points in the Wolcott system, we can thumb our noses at the Clan blockade and build up whatever forces we need for staging raids against our captive worlds. I also believe there may be profit in attempting to disrupt relations between the Jaguars and Clan Nova Cat on those worlds that they jointly administer; though relations now are relatively harmonious, the Clans are unused to such cooperation with each other. It may take very little to provoke a quarrel between them.

As to Your Excellency's other project, Wolcott seems eminently suitable as a base for that operation.

The pilots of both BattleMechs must make a Piloting Skill Roll to avoid falling. When the domino effect push originates from one of a BattleMech's four side hexes, however, the BattleMech can avoid the domino effect by moving 1 hex directly forward or back, if it has sufficient MP remaining from the Movement Phase, if it is both mobile and standing, and if the player made a successful Piloting Skill Roll for that BattleMech. If the Piloting Skill Roll was not successful, the BattleMech would have fallen, and missed this chance to step out of the way.

The domino effect continues as long as BattleMechs remain in hexes adjacent to one another in the direction of the effect, and none of them manage to step out of the way.

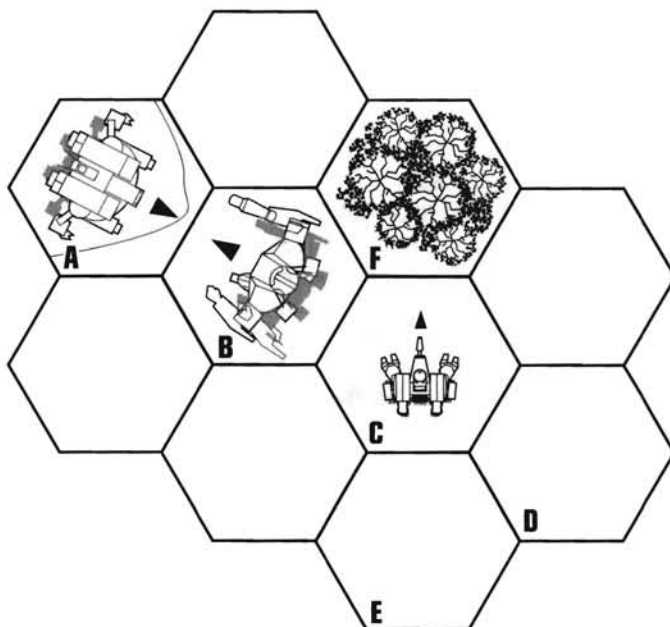

*The BattleMech in Hex A has fallen 1 level into Hex B. The BattleMech standing in Hex B will be forced into Hex C, and must make a Piloting Skill Roll to avoid falling. The BattleMech in Hex C, however, can try to avoid the domino effect by moving. First, the player must make a Piloting Skill Roll. If the roll fails, the 'Mech will fall into Hex D, and if another 'Mech occupied that hex, the domino effect would continue. However, if the roll is successful, and the 'Mech has at least 1 MP left from the previous Movement Phase, it may move one hex directly backward, into Hex E, ending the domino effect. If the BattleMech had 3 or more MP left, it could choose to move forward into the heavy woods in Hex F.*

## HEAT

One of the most severe problems facing any BattleMech in combat is internal heat build-up. Though every BattleMech can dissipate heat through its heat sinks or by standing in water, the BattleMech builds up heat whenever it moves or fires its weapons.

Even when using both dissipation methods to cool its systems, a high rate of activity commonly produces more heat than a BattleMech can dissipate. It is possible for a BattleMech to overheat and continue to function, but a pilot who pushes his BattleMech past its limits eventually must pay the price. As a BattleMech's internal heat increases, it moves more slowly and its weapons fire becomes less accurate. If its internal heat reaches a certain level, the ammunition that it carries may explode.

# COMBAT

The BattleMech's fusion reactor may even shut down, causing the BattleMech to become inactive and immobile until the heat drops below a certain point.

Vehicles do not generate heat in the same manner as BattleMechs. A vehicle only needs to be designed with enough heat sinks to fire all of its energy weapons at once. Because of its more open (and flimsier) structure, a vehicle can automatically shed heat built up from movement or from firing non-energy weapons.

## HEAT POINTS

Players track the internal heat of a BattleMech by the number of Heat Points (HP) it builds up. The greater the number of Heat Points, the greater the internal heat. The player keeps track of his BattleMech's Heat Points using the column of boxes on its record sheet labeled Heat Scale. The Heat Scale records heat levels from 0 to 30 Heat Points. As the BattleMech's internal heat reaches various levels on the Heat Scale, the BattleMech will suffer the adverse effects listed at those levels on the scale.

### ◆ Building Up Heat

Different activities build up heat at different rates. A good MechWarrior balances the tactical value of an activity against the heat it will add to his BattleMech. The Heat Point Table indicates the number of Heat Points generated by various activities and damage. It also shows the number of Heat Points that a BattleMech can dissipate through its heat sinks and by standing in a Water hex. Note that there are two types of heat sinks available: standard heat sinks that dissipate 1 point of heat per turn, and double heat sinks that dissipate 2 points of heat per turn.

### HEAT POINT TABLE

Activity	Heat Points
Walking	+1 per turn
Running	+2 per turn
Jumping	+1 per hex (minimum of 3 per turn)
Trying to Stand	+1 per attempt
Weapons Fire	Per Weapons and Equipment Tables, p. 104
Heat Sink	-1 per operational heat sink -2 per operational double heat sink -1 additional per heat sink under water (6 HP maximum) -2 additional per double heat sink under water (6 HP maximum)
First Engine Hit	+5 per turn
Second Engine Hit	+10 (total) per turn
Fire	
Walking through	+2 per hex
Standing in	+5 per turn

Note that jumping uses more heat than walking or running, even if the BattleMech moves only 1 hex, because firing the jump jets adds a minimum of 3 Heat Points. The Heat Point cost for jumping depends on the length of the jump. The farther the jump, the longer the jump jets are used and the more heat they generate. To determine the number of Heat Points generated by jumping, count the hexes moved. If the 'Mech jumps 3 or fewer hexes, the Heat Point cost is 3 points. If the number of hexes moved is 4 or more, the Heat Points generated equals the number of hexes jumped.

A MechWarrior may actually wish to build up heat in some situations, particularly if his BattleMech is equipped with triple-strength myomer. Building up heat is most easily accomplished by shutting off as many heat sinks as desired during the End Phase of any turn; heat sinks shut off this way dissipate no heat, and they may only be switched back on during a subsequent End Phase.

### Recording Heat Build-Up

During the Heat Phase of every turn, each player adds up the Heat Points built up by his BattleMech. He subtracts the heat dissipated by his BattleMech's heat sinks and any additional dissipation if his BattleMech occupies a Water hex. The result may be positive or negative. Add this number to the current level of heat shown on the Heat Scale on the BattleMech's record sheet. If the number is negative, adjust the Heat Scale downward; if the result is positive, adjust the Heat Scale upward. The level of heat shown on the Heat Scale cannot drop below 0 or rise above 30.

We suggest that players mark the Heat Scale with a pencil, because the heat will rise and fall many times during the game.

### EFFECTS OF HEAT

The effects of excessive heat cause the BattleMech to function less efficiently. It will move more slowly, fire less accurately, and possibly shut down or even explode. Some of these effects are permanent, but others are negated when the 'Mech cools.

The BattleMech suffers the effects listed below after the heat for the turn has been adjusted as described in **Recording Heat Build-up**.

### Movement Effects

At 5, 10, 15, 20, and 25 Heat Points, subtract the number indicated from the BattleMech's Walking MP. For example, at 5 Heat Points, subtract 1 from the BattleMech's Walking MP as long as the heat is at or above 5. Remember that Running MP are 1.5 times the current Walking MP; if the Walking MP are reduced, the BattleMech's Running MP must also be recalculated, rounding fractions up.

This effect is not cumulative with any previous heat-caused MP loss. When a BattleMech's heat build-up reaches 5 on the Heat Scale, its Walking MP are reduced by 1. When the build-up reaches 10 on the Heat Scale, its Walking MP are reduced by 2 total, not 2 more.

WOLFNET ARCHIVE FILE: 98743-5D2-66/5/1

**From *Bloody but Unbowed: A History of House Liao*, by Mandrinn Li Chao-min (Morning Swallow Press, 3056)**

The Capellan Confederation, founded during the 24th century by the Liao dynasty, was once one of the most potent Successor States. The centuries of the Succession Wars, however, cost the Confederation much of its territory, which went to the hated Federated Suns. During the Fourth Succession War alone, the Confederation gave up more than 100 worlds to the mighty Davion military machine. The secession of the province of St. Ives, which became quite friendly with the budding Federated Commonwealth, compounded the Confederation's losses.

Beginning with Chancellor Maximilian Liao's reign, the Confederation became synonymous with scheming and treachery. This scheming had a high price: many people believe that the near-success of Maximilian Liao's plot to replace Hanse Davion with a double drove the Davion prince to declare the Fourth Succession War as revenge.

Though battered by that war, the Liao state refused to lie down and die. Maximilian's less-than-stable daughter, Romano Liao, rebuilt her state and hardened its people. Her son and successor, Sun-Tzu Liao, now leads his realm single-mindedly toward restoring its lost glories.

To this end, Sun-Tzu has allied with Thomas Marik and the Free Worlds League. The Confederation has also become a hiring haven for mercenaries throughout the Inner Sphere. When Thomas Marik sought revenge against Victor Davion for concealing the death of his son, Sun-Tzu took advantage of his opportunity. In a brilliant lightning strike, the rejuvenated Capellan army captured the planets of the Commonwealth's Sarna March originally the Capellan Sarna Commonality. Liao troops remain dug in on those worlds while they await orders to continue their advance. House Liao has risen from its supposed deathbed to bring war to its deadly enemies.

When the heat build-up is reduced below the point at which the effect occurs, the BattleMech regains 1 Walking MP, though previous losses remain in force. Thus, if the heat falls below 10 on the Heat Scale, the -2 MP effect is removed, but the -1 MP effect is still in force until the heat drops below 5.

Note that a BattleMech's Jumping MP are not affected by the reduction in Walking MP due to heat build-up.

## Weapon Attack Effects

At 8, 13, 17, and 24 Heat Points, add the number indicated to the BattleMech's base to-hit number for weapons attacks. For example, at 8 Heat Points, add 1 to all base to-hit numbers while the heat is at or above 8. Treat these effects like movement effects: they are not cumulative and may be negated by reducing the heat build-up.

## Shutdown Effects

At 14, 18, 22, 26, and 30 Heat Points, a BattleMech shuts down its fusion reactor automatically as a safety procedure. Until the MechWarrior restarts the reactor, the BattleMech may not move or fire.

This effect may be avoided if the MechWarrior is able to override the fusion reactor's safety shutdown procedure, as indicated by the Avoid number listed with the effect (shutdown cannot be avoided at 30 Heat Points). The player rolls 2D6. If the result is equal to or greater than the Avoid number (4+, 6+, and so on), the pilot avoids shutdown until the heat rises to that level again. If the heat rises to another trigger level, or falls and rises to the same trigger level, the player must roll 2D6 to avoid the effect again. If heat accumulation reaches 2 trigger levels in one turn, roll 2D6 only once, against the highest Avoid number.

If the BattleMech shuts down, it remains motionless and cannot build up any heat by its own actions. Its heat sinks will still work, however, and so will continue to dissipate the excess heat. For every turn that the overheated 'Mech remains motionless, the heat level will drop, and the player may attempt to restart the reactor during each Heat Phase. To do this, the player rolls 2D6. If the result is equal to or greater than the highest current Avoid number, he can restart the reactor. A BattleMech may move and fire in the turn following the turn in which the reactor was restarted. When the heat drops below 14 on the Heat Scale, the reactor restarts automatically, even if the pilot is out of action.

A shutdown BattleMech offers a target for aimed shots (p. 39).

## ◆ Ammunition Effects

If the heat level reaches or exceeds an Ammo Explosion threshold of 19, 23, and 28 Heat Points, the ammunition carried in the BattleMech might explode. The explosion may be avoided by pure luck, as indicated by the Avoid number. To see if the 'Mech avoids an explosion when the heat level reaches an Ammo Explosion threshold, the player rolls 2D6. If the result is equal to or greater than the indicated Avoid number, the ammo remains intact.

When a BattleMech's ammo explodes due to overheating, the ammunition with the most destructive ammo rack explodes first. An ammo rack is defined as the damage that one turn's worth of shots will do. Thus, a rack of machine gun ammo has a Damage Value of 2, an AC/10's Damage Value is 10, an LRM-15 has a Damage Value of 15, and an SRM-6 has a Damage Value of 12. When the 'Mech carries two racks with equivalent Damage Values, the BattleMech's pilot chooses which ammo explodes. All of the appropriate ammo type in a single critical hit location explodes. If there is more than one critical hit location with the appropriate ammo type, the one with the most shots remaining will explode. If there are two or more locations with an equal number of shots remaining, determine randomly the one that explodes.

Ammunition explodes with a Damage Value equal to the ammo's Damage Value times the shots remaining. Missile ammo explodes with a force equal to the number of missiles remaining multiplied by their Damage Value. Thus, one ton of AC/10 ammo explodes with a force of 100. A full ton of LRM-20s explodes with a force of 120 (20 x 6 x 1). All damage from exploding ammo strikes the internal structure. Excess damage is transferred to the internal structure of the next section per the Damage Transfer Diagram.

An ammo explosion always causes 2 points of damage to the MechWarrior from feedback through his neurohelmet.

## MechWarrior Effects

If the life-support systems suffer a critical hit, the MechWarrior suffers 1 point of damage for every turn that the BattleMech's internal heat reaches 15 or more. For every turn that the heat rises higher than 25, the MechWarrior suffers 2 points of damage.

*A Warhammer begins a turn with a Heat Scale reading of 4. During the turn, it fires both its PPCs and walks (generating a total of 21 Heat Points). The BattleMech still has 16 standard heat sinks working. They dissipate 16 of the 21 Heat Points, leaving 5 to build up. During the Heat Phase, these 5 points are added to the 4 already on the Heat Scale, bringing the total to 9. In the next turn, the BattleMech must reduce its Walking MP by 1 and add +1 to its to-hit number for weapons attacks.*

*If the BattleMech repeats these actions in the next turn, the player must add 5 more Heat Points to the Heat Scale, bringing the total to 14. The player must roll a 4 or higher on 2D6 to avoid having his BattleMech's fusion reactor shut down. Even if he avoids the shutdown, he must reduce the Warhammer's Walking MP by 1 more, for a total of 2, until its heat falls below 10 on the Heat Scale. At the same time, the 'Mech fires its weapons with a +2 to-hit modifier.*

## BUILDINGS

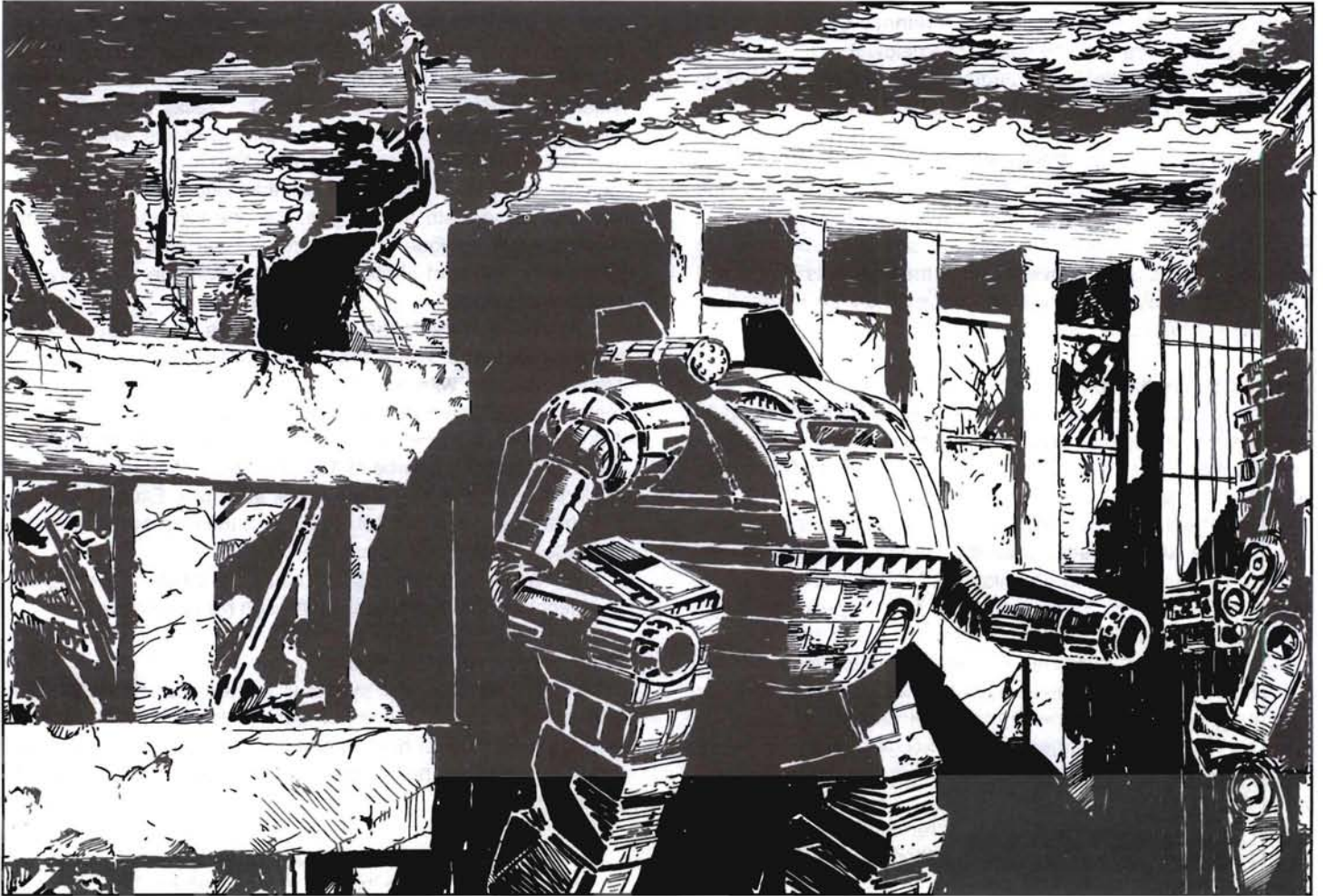

BattleMechs evolved out of the need for a highly mobile weapons platform that could be dropped from space, perform extended operations with a minimum of supplies, and carry enough firepower to win the planned objective. This machine as designed can perform all these missions easily, especially when moving through Clear terrain.

Historically, cities and urban areas made it difficult for armored vehicles to successfully perform their objectives, and cities still cause problems for BattleMechs. Battles fought in long, narrow streets filled with buildings that block line of sight, provide enemy hiding places, and offer limited protection from weapons fire required a change in tactics and operations. In urban combat, even unarmored infantry may substantially damage a BattleMech.

### BUILDING TYPES

The urban combat of **BattleTech** uses four types of buildings: Light, Medium, Heavy, and Hardened. Each type is rated

to describe the damage it can withstand, the protection it provides, and the weight it can bear. Two numbers describe buildings in **BattleTech**: the Construction Factor (CF) and Elevation.

Treat building elevation exactly like other terrain elevation for both line of sight and movement, with each level of a building being about 6 meters high.

The Construction Factor (CF) is used to determine how the physical structure of the building affects the play of the game. The CF is the number of points of damage that a building can take before being reduced to rubble. It is also the number of tons of additional weight a building can support without collapsing. Regardless of a building's current Construction Factor, its type never changes. A damaged Heavy Building with a current CF of 15 is still a Heavy Building.

If the scenario does not specify a building's CF, assume that a Light Building has CF 15, a Medium Building has CF 40, a Heavy Building has CF 90, and a Hardened Building has CF 120. These values represent the maximum CF for Light,

# BUILDINGS

Medium, and Heavy Buildings. The maximum CF for a Hardened Building is 150.

Building counters are used to represent buildings on the mapsheet. Counters provided by FASA show a picture of the intact building on one side, labeled according to its type and elevation. The other side represents rubble. Whatever players choose to use as counters, those pieces should contain the same information as provided on FASA counters. In the case of building counters that cover more than a single hex, the CF of the building represents the whole counter, not its individual hexes.

## MOVEMENT EFFECTS

BattleMechs can move into or onto buildings. Ground vehicles cannot move onto the top of a building. If the current CF of a building is equal to or greater than the tonnage of a BattleMech, then that BattleMech can jump to the top of the building or climb up to the top of buildings of Levels 1 or 2 (in this case, treat buildings as hills for purposes of movement). If the current CF is less than the BattleMech's tonnage, the building will collapse and the BattleMech will fall a distance equal to the elevation level of the building, taking falling damage.

The Building Modifiers Table summarizes movement costs and modifiers for each type of building.

Every time a BattleMech or vehicle moves into a building (by entering a Building hex), it passes through a wall, and the MechWarrior or driver must make a Piloting Skill Roll adding all appropriate modifiers from the Piloting Skill Roll Table, p. 25. In addition, modify the Piloting Skill Roll for the unit's movement per the Building Movement Modifiers Table. If the Piloting Skill Roll is successful, the unit takes no damage. If the roll is unsuccessful, the BattleMech or vehicle takes damage on the Front side equal to the building's current CF divided by 10 (rounded up). Note that the BattleMech does not fall. The player must also make a Piloting Skill Roll when the 'Mech leaves a building and when moving from hex to hex inside a single building.

In addition, whenever a BattleMech or vehicle moves through a building wall (by moving from or into a Building hex), the building suffers damage equal to the unit's tonnage divided by 10 (rounded up).

### BUILDING MOVEMENT MODIFIERS TABLE

Hexes Moved in Turn	Piloting Skill Modifier
1-2	0
3-4	+1
5-6	+2
7-9	+3
10+	+4

*A MechWarrior with a Piloting Skill level of 5 piloting a 70-ton Archer wants to move through a Medium Building to fire at units on the other side. The Archer runs 1 hex to reach the hex adjacent to the building, then spends 3 MP to enter the hex containing the building. As the 'Mech passes through one wall, the player must make a Piloting Skill Roll, modified by +1 because this is a Medium Building. As shown on the Building Movement Modifiers Table, the player need not add a modifier for its unit's movement because the Archer only moved 2 hexes. The Archer's player rolls 2D6 with a result of 10, which is a success. The BattleMech suffers no damage, but the building takes 7 points of damage (the Archer's 70 tons divided by 10). The Archer must make a second Piloting Skill Roll in order to leave the Building hex. The player must add a Building Movement Modifier of +1 this time, because this is the 'Mech's third hex of movement. The die roll result is 3, less than the 7 needed to pass through the wall without taking damage. The Archer suffers 4 points of damage to its Front side (the current CF of 33, divided by 10, rounded up), and the building suffers a further 7 points of damage, reducing the current CF to 26. The Archer spends its remaining 1 MP to move to Hex C.*

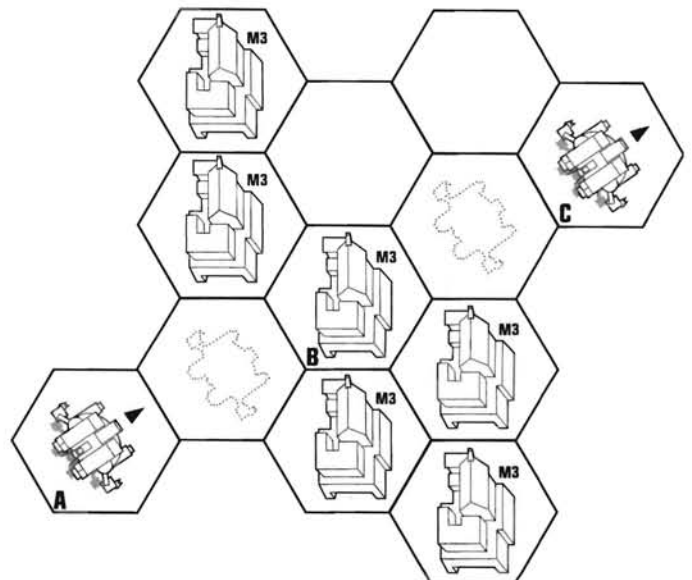

### BUILDING MODIFIERS TABLE

Building Type	Original CF	MP Cost	Piloting Skill Modifier
Light	1-15	2	0
Medium	16-40	3	+1
Heavy	41-90	4	+2
Hardened	91-150	5	+5

# BUILDINGS

WOLFNET ARCHIVE FILE: 55473-FC6-33/4/9

From *The Strategist's Handbook: Case Studies of Famous Fighting Units*, Glory Press, 3056

The Gray Death Legion owes its successes in the field to tactical brilliance, superior technology, and the intelligence to take advantage of luck.

The Legion began as a handful of troopers and a couple of 'Mechs. In their maiden battle, those fighters foreshadowed the fame they would attain as the Inner Sphere's foremost tacticians, saving the planet Trel I from a Draconis Combine attack while revolutionizing combined-arms combat. Under the leadership of Grayson Death Carlyle, the Legion became masters of combined-arms tactics. Using 'Mechs, armor, infantry and aerospace forces in concert, the Legion racked up an impressive list of victories. They also pioneered the use of infantry to take down enemy BattleMechs. The Legion achieved that "impossible" task so often that the unit's anti-'Mech commandos became a feared sight on the battlefield.

During the Clan invasion, the Legion combined tactics and high-tech to fight the Clans to a draw. In 3028, the Legion had earned fame with its discovery of the so-called "Gray Death Memory Core," a Star League-era databank from which the Successor States rebuilt lostech that had vanished during the Succession Wars. In the battle for Pandora against Clan Jade Falcon forces, the Legion fielded advanced 'Mechs built from lostech designs, and infantry in power suits reverse-engineered by the NAIS from captured Clan battle armor. The Legion's techs modified the power suits for extra speed and firepower by sacrificing armor. The effort paid off; Legion forces kept the Clans bogged down until their defeat on Tukayyid forced them to lift off-planet.

Strategy and luck won the day for the Legion on their homeworld of Glengarry. The Legion turned the tables on rebels from Skye who attacked in the hopes of capturing the planet. The rebels failed to capture Davis Clay, a member of the Legion's training battalion. Clay freed his captured comrades, including Grayson Carlyle's son, Alexander. Under the younger Carlyle's command, the Legion held out long enough for reinforcements to arrive.

Ground vehicles can only enter or exit the ground level of a building. If a building is Level 2 or less, or if a BattleMech has a Jumping capability at least equal to the height of the building, then the BattleMech may land on or otherwise reach the building's roof through normal expenditure of MP (see Movement, p. 18). Likewise, jump infantry and battle armor may move to the roof of any building that is Level 3 or less using normal expenditure of MP.

A BattleMech or infantry unit may enter a building at an elevation higher than ground level only if it enters the building from an adjacent hex with an elevation equivalent to the building level being entered. It costs infantry 1 MP to enter a building and 1 MP to change levels within a building.

Normal stacking limitations are in effect at each level in a building. Interior floors of a building sustain the same weight as its roof.

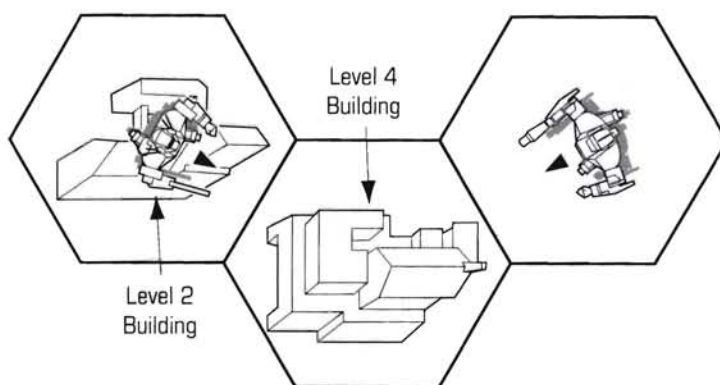

*A Stinger is adjacent to the Level 4 building in Hex A. The Stinger may attempt to enter the building at ground level or it may jump up to the roof. The Wasp on the roof of the adjacent Level 2 building may jump or climb to the roof of the building in Hex A, or it may enter the building on its second level.*

## COMBAT EFFECTS

Combat in and around buildings may cause damage to the buildings and to the units inside buildings.

### DAMAGE TO BUILDINGS

When a building suffers damage, simply subtract the points of damage from the building's current CF and write the resulting number in pencil on the back side of the counter. When the cumulative damage equals or exceeds the building's CF, flip the counter over to the rubble side. The building is now rubble for the rest of the game.

For every point of damage that a Building hex takes as a result of combat, fire, or movement, the building loses 1 CF. When the CF of a building is reduced to 0, all the hexes it occupies are reduced to rubble.

Units firing directly at a building add a -4 to-hit modifier for firing at immobile targets. Shots aimed at buildings from adjacent hexes always hit, as do all physical attacks. All missiles launched from an adjacent hex will strike the target; the player need not roll on the Missile Hits Table.

### ◆ DAMAGE TO UNITS INSIDE

A unit firing at a BattleMech or vehicle that is inside a building does not modify the to-hit number to represent this situation, but the building provides some protection against damage to those units inside. The building absorbs an amount of damage

# BUILDINGS

not modify the to-hit number for the terrain. Do not add a level to a BattleMech's height when it is inside a building. If it is on the second floor of the building, it can fire directly at infantry on the second floor, but only indirectly at infantry on the third floor.

If a building takes more damage than its current CF, any unit inside suffers damage as the building collapses equal to the building's CF at the beginning of the current phase divided by 10, multiplied by the number of levels of building above the affected unit (round up). Infantry units suffer 3 times the normal damage caused by a collapsing building, split up into 5-point clusters in the same way as LRM attacks when applied to battle armor units.

A BattleMech occupying an upper floor or the roof of a collapsing building also suffers standard falling damage in addition to the damage caused by the collapse (see above), according to the number of levels fallen. Units on top of a collapsing building suffer damage as though they were on the highest level inside it.

It is possible for many units to occupy the same hex if they are on different levels of the same building. When units on different levels inside a building fire at each other, use the standard to-hit procedures, with the following modifications. The difference in levels is the range. If the building occupies more than 1 hex, and the target is not in the same hex as the unit firing but still in the building, then include the horizontal distance when determining range. Finally, add a +3 to-hit modifier for partial concealment. Do not use minimum range modifiers in this case. If a shot from a different level hits a BattleMech, roll 1D6 and consult the appropriate section of the Special Hit Location Table. If a shot hits a vehicle, consult that vehicle's Hit Location Table. Note that the shot hits a randomly determined side of the vehicle. Remember that the building protects all units from a certain amount of damage.

equal to its current Construction Factor divided by 10 (round up) before any damage actually hits the BattleMech or vehicle. The building absorbs the same amount of damage from each attacker (though not from each separate weapon). For example, if five BattleMechs are firing on a target in the same building, the building would absorb the same amount of damage from each 'Mech attack before any damage affected the target. The building takes damage (reduces its CF) only after all weapons fire is complete.

All shots that were aimed at a target inside a building and miss do full damage to the building instead.

*A Marauder and a Rifleman each make a successful attack against a Hunchback that is inside a Heavy Building, each inflicting 10 points of damage. The building has a current CF of 82. The Rifleman's damage to the Hunchback is reduced by 9 points because of the protection of the building ( $82 \div 10$ , rounded up). The Marauder's damage to the Hunchback is also reduced by 9. The building's new CF will be 64 ( $82 - 9 - 9 = 64$ ).*

## Infantry

Units that fire weapons at infantry inside a building must do so according to the following special rules. When the attacking unit is outside or on a different level within the same building, the fire must be directed at the building itself, and then any damage also affects the infantry. For details, see **Infantry**, p. 68. If the attacking unit is inside the building and on the same level, use the normal weapon- and physical-attack rules, but do

## SPECIAL HIT LOCATION TABLE

### Shot from Above

Die Roll (1D6)	Hit Location
1	Left Arm
2	Front/Rear Left Torso*
3	Front/Rear Center Torso*
4	Front/Rear Right Torso*
5	Right Arm
6	Head

### Shot from Below

Die Roll (1D6)	Hit Location
1	Left Leg
2	Left Leg
3	Front/Rear Left Torso*
4	Front/Rear Right Torso*
5	Right Leg
6	Right Leg

\*The attack hits the Front if from the front or the side. It hits the Rear if from the rear.

## VEHICLES

BattleMechs reign supreme on the battlefield, but armored vehicles can hold their own in combat. Though they rarely pack as much punch as a BattleMech, they are cheaper to build and offer an even fighting chance in situations where a BattleMech's capabilities are limited, such as cities and other urban areas.

**BattleTech** provides rules for three types of vehicles: ground, air (VTOL), and naval. Ground vehicles include wheeled, tracked, and hovercraft; VTOLs are primarily rotary-wing craft but also include tilt-rotor aircraft and other small vertical takeoff and landing aircraft; naval vessels are classified into surface vessels such as displacement hull ships (normal boats), hydrofoils, and submarines. Each type of vehicle offers advantages and disadvantages, as described in the following rules.

### MOVEMENT

A vehicle changes its position on the mapsheet by using one of three possible movement modes or actions. During a turn, a vehicle can elect to use its Cruising MP or its Flank MP, or to Stand Still. These movement modes correspond to a BattleMech's Walking, Running, and Standing Still modes. A vehicle can use only one movement mode per turn.

Vehicles may combine backward and forward movement in a turn only if they are moving at cruising speed.

### GROUND VEHICLE MOVEMENT

Ground vehicles are restricted from certain types of terrain. See the Movement Cost Table in **Movement**, p. 19, for a list of restricted terrain.

Ground vehicles can change elevation levels at a cost of 2 MP per level. A ground vehicle may only change 1 level per hex traveled, and cannot change levels within buildings.

A ground vehicle's turret (if it has one) can be turned to face any hexside during the Reaction Phase.

Treat hovercraft moving over water like surface vessels (see **Naval Movement**, p. 62).

### VTOL MOVEMENT

Like other vehicles, a VTOL may move at either cruising or flank speed during the Movement Phase. Making a facing change or entering a new hex, regardless of the terrain type, costs VTOLs 1 MP. VTOLs may also move vertically on the mapsheet at a cost of 1 MP per elevation level that it ascends or descends. A VTOL can move any number of elevations up and down in a single hex, as long as it has sufficient MP. The only movement a VTOL can make while at ground level (landed) is to ascend at least one elevation level above the ground. A VTOL that begins or ends its movement at an elevation equal to the terrain's elevation has landed. VTOLs may only land in Clear, Paved, or Building hexes (on the roof).

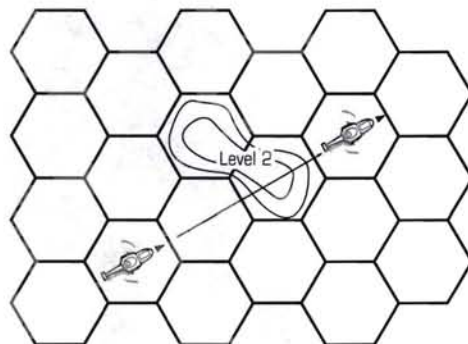

*A VTOL starts its movement landed behind a Level 2 hill. The player decides to move the VTOL to the other side of the hill, 3 hexes away. It costs the VTOL 3 MP to rise high enough in the starting hex to fly over the hill, 3 MP to move to the new hex, and 3 MP to land again, for a total of 9 MP.*

### Crashing

VTOLs that enter a hex horizontally at or below the elevation level of the terrain in the hex are considered to have flown into the side of that terrain and crashed. VTOLs cannot fly at or below the tops of trees while in wooded hexes (2 levels high), and cannot fly at or below the elevation level of a building in a Building hex unless they are landing on the building.

VTOLs take damage from crashing on the Front side. The damage is equal to the number of hexes that the VTOL moved in that turn times its tonnage, divided by 10 (rounded up). Group the damage into 5-point clusters, assigning any extra damage to a small cluster. The attacking player then rolls once on the VTOL Hit Location Table for each cluster. If the VTOL is still functional after taking damage from the crash, and it can normally land in the terrain of the hex in which it crashed, the VTOL is considered to have landed in the hex and can move as normal in the next turn. Otherwise, the VTOL is considered destroyed. The VTOL may not attack in the turn that it crashes.

### Sideslipping

A VTOL moving at flank speed may attempt to turn, and it may fail. The player of a VTOL moving at flank speed that continues to move after a facing change must make a Piloting Skill Roll. If the roll is successful, the VTOL follows its desired course. If the roll fails, the VTOL sideslips into the hex that it would have moved to without the facing change. A Piloting Skill Roll is not required if the VTOL does not move after it changes facing.

The player has no opportunity to change the elevation of a VTOL that sideslips before it enters the new hex. Therefore, it is possible for a VTOL to sideslip into terrain that causes it to crash. If the sideslip does not result in a crash, a VTOL may move normally (continue in the direction of the facing change) after the failed turn.

# VEHICLES

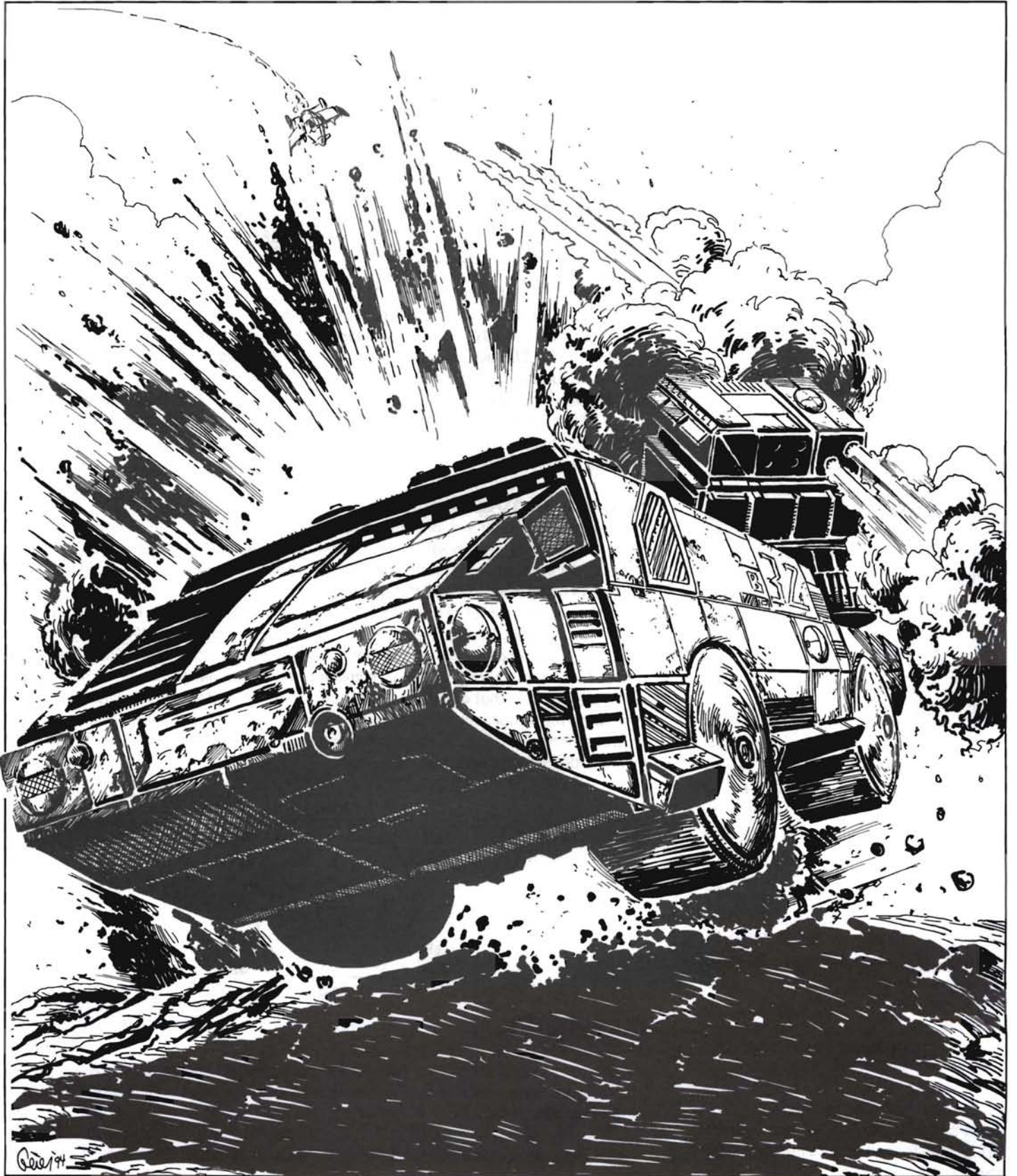

# VEHICLES

WOLFNET ARCHIVE FILE: 44831-PK7-43/2/1

**From Reading The Remembrance: A Dissertation on Clan Literature, by Corrine Wexford (ComStar Scholastic Press, 3055)**

Those who believe they understand the Clans through observing their conduct on the battlefield would do well to study the Clans' epic poem, *The Remembrance*. It presents a vastly different picture of Clan ideals and how they function in Clan society. Clan Jade Falcon's version of *The Remembrance* provides a clear case in point: the verses honoring Star Colonel Aidan Pryde, who rebuilt the disgraced Falcon Guards into a prestigious fighting unit.

Since his death on Tukayyid, Aidan Pryde has become a hero to his Clan. The opening lines about him testify to this status:

An eyes born/By hardship, grown strong;/For his Bloodname he risked all; death, disgrace;/Concealing his true worth beneath a freeborn face,/Enduring suffering with a quiet strength./From shame he drew glory,/Redeeming the evil of Twycross;/Our dishonor and defeat he turned to bright victory.

To any familiar with Aidan Pryde's life, the worship accorded him by this fanatically traditional Clan is astonishing. Pryde achieved his Bloodname and rank among the Jade Falcons using tactics that many Clansmen would describe as "dirty freebirth trickery," and throughout his career refused to play by the rules. He flushed out of military training, and the Clans never give failures a second chance. Yet this man grabbed one by the throat and made the most of it. *The Remembrance* immortalizes Pryde's unClanlike audacity:

O Falcons, praise his name through all our generations!/ For greatness grew within him/As the fledgling grows within the shell./ The shell was the Way of the Clan,/Which he shattered with courage and will/As with beak and talons of iron./Denying the Way, he fulfilled the Way;/Pryde broke those who would break him.

As is clear from the above verses, Clan Jade Falcon honors Aidan Pryde not in spite of, but because he flouted Clan traditions. The line, "Denying the Way, he fulfilled the Way" makes this point clearly. It suggests that the rigidity of Clan ways is a deliberate choice, designed not to crush men like Aidan Pryde, but to produce them.

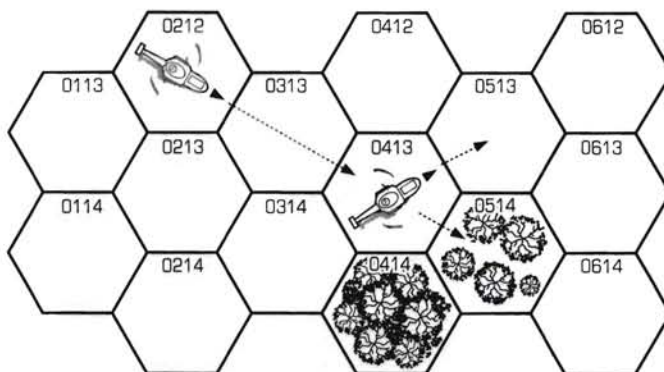

A VTOL at Level 1 in Hex 0212 declares that it will move at flank speed, and moves 2 hexes without changing elevation. When the VTOL arrives in Hex 0413, the VTOL changes facing and then declares that it will move into Hex 0513. The player makes a Piloting Skill Roll with a result of 4. Because he needed a 5 to succeed, the VTOL sideslips into Hex 0514, Light Woods. Because the top of the trees are at Level 2 and the VTOL is at Level 1, the VTOL crashes in the hex. If the VTOL had climbed to Level 3 before attempting the turn, then it would have risen above the trees and could have continued to move normally into Hex 0613.

## NAVAL MOVEMENT

Naval movement includes movement on and below the water's surface. Surface naval vessels may only move through Depth 1 or deeper Water hexes, at a cost of 1 MP per hex entered, regardless of depth. For line of sight purposes, a surface vessel is at Level 0 (on the surface of the water).

Also regardless of the depth, a submarine expends only 1 MP for each new Water hex it enters. Submarines can move vertically at a cost of 1 MP per depth that it ascends or descends. A submarine can move any number of levels up and down in a single Water hex as long as it has sufficient MP. A submarine cannot descend to a depth greater than that of its hex or ascend above the surface of the water (Level 1). In order to move horizontally or change facing, the submarine must be at a depth one level less than the depth of the hex it occupies. The player need only record the submarine's depth at the end of its movement.

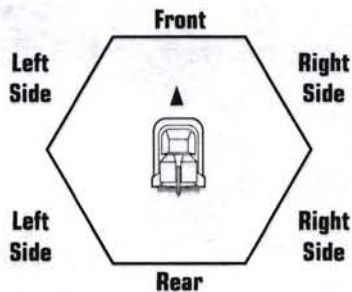

## COMBAT

Vehicles use the BattleMech rules for firing arcs, multiple targets, and to-hit modifiers. Vehicles take hits to only 6 locations. The diagram shows the Front, Side, and Rear damage locations for all vehicles.

When a vehicle takes a hit, roll 2D6 and consult the Hit Location Table for that type of vehicle to determine the component that took damage. Other results may also apply, as noted on the table.

# VEHICLES

A vehicle can be destroyed by a critical hit result or by losing all internal structure boxes in any one location. Vehicles take damage in the same way as BattleMechs—first against armor and then against internal structure.

## GROUND VEHICLE HIT LOCATION TABLE

Dice Roll (2D6)	Front/Rear	Side
2	Armor (critical)	Armor (critical)
3	Armor <sup>1</sup>	Armor <sup>1</sup>
4	Armor <sup>2</sup>	Armor <sup>2</sup>
5	Armor <sup>3</sup>	Armor <sup>2</sup>
6	Armor	Armor
7	Armor	Armor
8	Armor	Armor
9	Armor	Armor <sup>3</sup>
10	Turret Armor	Turret Armor
11	Turret Armor <sup>4</sup>	Turret Armor <sup>4</sup>
12	Turret Armor (critical)	Armor (critical)

<sup>1</sup>A track, axle, or lift fan has been destroyed; the unit cannot move for the rest of the game. If a hovercraft suffers this hit while over water, it sinks and is destroyed.

<sup>2</sup>A drive, wheel, or airskirt has been damaged; -1 Cruising MP for the rest of the game.

<sup>3</sup>If the vehicle is a hovercraft, an airskirt has been damaged; -1 Cruising MP for the rest of the game. If not a hovercraft, no additional effect.

<sup>4</sup>The turret locks in its current position and cannot be moved for the rest of the game; it can only fire out of its current arc. If there is no turret, no additional effect.

**Note:** If there is no turret, then all turret hits become normal armor hits.

## NAVAL COMBAT

Naval units use all standard vehicles rules but have unique Hit Location and Critical Hit tables. Submarine underwater operations and the use of torpedoes are described in **Underwater Operations**, p. 95 in **Special Case Rules**.

## NAVAL HIT LOCATION TABLE

Dice Roll (2D6)	Front/Rear	Side
2	Armor (critical)	Armor (critical)
3	Armor <sup>1</sup>	Armor <sup>1</sup>
4	Armor <sup>2</sup>	Armor <sup>2</sup>
5	Armor <sup>3</sup>	Armor <sup>2</sup>
6	Armor	Armor
7	Armor	Armor
8	Armor	Armor
9	Armor	Armor <sup>3</sup>
10	Turret Armor	Turret Armor
11	Turret Armor <sup>4</sup>	Turret Armor <sup>4</sup>
12	Turret Armor (critical)	Armor (critical)

<sup>1</sup> The engine room or foils are destroyed; the vessel cannot move for the rest of the game.

<sup>2</sup> The engine room or foils are damaged; -1 Cruising MP for the rest of the game.

<sup>3</sup> If the vessel is a hydrofoil, its foils are damaged; -1 Cruising MP for the rest of the game. If not a hydrofoil, no additional damage.

<sup>4</sup> The turret locks in its current position and cannot be moved for the rest of the game; it can only fire out of its current arc. If there is no turret, no additional effect.

**Note:** If there is no turret, then all turret hits become normal armor hits.

## GROUND VEHICLE CRITICAL HITS TABLE

Die Roll (1D6)	Result
1	Crew stunned (No actions for next 2 turns)
2	Main weapon jams (No fire from largest system for 1 turn)
3	Engine hit (No movement for rest of game)
4	Crew killed (Vehicle out of game)
5	Fuel tank hit (Vehicle explodes)
6	Ammo/power plant hit (Vehicle explodes)

## NAVAL CRITICAL HITS TABLE

Die Roll (1D6)	Result
1	Crew stunned (No actions for the rest of this turn and 2 more turns)
2	Main weapon jams (No fire from largest system for 1 turn)
3	Engine hit (No movement for rest of game)
4	Crew killed (Vehicle out of game)
5	Fuel tank hit (Vehicle explodes)
6	Ammo/power plant hit (Vehicle explodes)

# VEHICLES

WOLFNET ARCHIVE FILE: 66587-JH3-43/7/5

From *The Life of Thomas Marik*, by Theodore Blaine (Free Worlds Press, 3056)

Founded in the late 23rd century, the Free Worlds League is the oldest of the Successor States. The League has grown little over the centuries, partly because its Balkanized politics have made unified military action difficult at best. The position of Captain-General, held by a member of the Marik family for centuries, was intended as a temporary post; however, the ongoing Succession Wars and numerous internal troubles have turned it into a hereditary office.

The current Captain-General, Thomas Marik, has been the League's most effective ruler in years. The former ComStar precentor has done much to unite this fractious state, making it the powerful force it is today.

Though the Free Worlds League remained untouched by the Clan invasion, it became involved indirectly. When Prince Hanse Davion of the Federated Commonwealth offered as bait the advanced facilities at the New Avalon Institute of Science to cure Thomas' son Joshua of leukemia, Thomas Marik agreed that the League would produce much-needed high-tech 'Mechs and upgrade kits for units stationed on the invasion's front lines. These supplies helped narrow the immense technological gap between Clan and Inner Sphere BattleMechs.

To offset the Commonwealth's immense power, Thomas allied the League with the Capellan Confederation, sealing the alliance with a promised marriage between his daughter Isis and Sun-Tzu Liao, the Capellan chancellor. The marriage has yet to take place, however, as Thomas remains leery of having Sun-Tzu so close to his throne. To balance the potential threat from Sun-Tzu, Thomas opened the League members of the Word of Blake, a ComStar splinter group dedicated to restoring the order's religious nature.

The recent death of Joshua and Victor Steiner-Davion's attempt to hide it have forced Thomas to take action against the Commonwealth. The Free Worlds military supported a Capellan offensive in which the Confederation recovered half the worlds it lost in the Fourth Succession War. No one knows, however, whether Marik will continue to drown his grief in Davion blood.

## VTOL COMBAT

VTOLs use vehicle combat rules, with the following modifications. Because a VTOL does not benefit from terrain modifiers for a hex that it occupies while in flight, modify its weapons fire only if firing through a Light or Heavy Woods hex.

For VTOLs that expend MP in a turn, use the attacker and target movement modifiers for jumping.

Resolve line of sight as if the VTOL occupies a Clear hex at an elevation equal to the VTOL's present level.

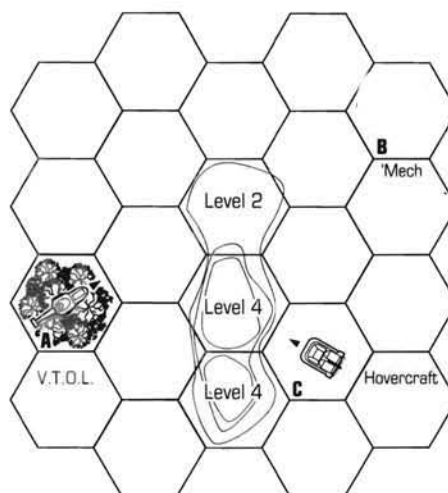

*The VTOL in Hex A is at Level 3, one level higher than the woods below it. The BattleMech in Hex B can see and be seen by the VTOL. The hovercraft in Hex C does not have line of sight to the VTOL because of the intervening Level 4 hill.*

A VTOL may not fire at a target in the same hex it occupies, regardless of its level.

When a VTOL takes a hit, use the VTOL Hit Location Table to determine the damage location. Other results may also apply, including critical hits. For damage resulting in critical hits, consult the VTOL Critical Hit Table.

### VTOL HIT LOCATION TABLE

Dice Roll (2D6)	Front/Rear	Side
2	Rotor Destroyed (critical)	Rotor Destroyed (critical)
3	Rotor Destroyed	Rotor Destroyed
4	Rotor (-1 MP)	Rotor (-1 MP)
5	Rotor (-1 MP)	Rotor (-1 MP)
6	Armor	Armor
7	Armor	Armor
8	Armor	Armor
9	Armor	Main Weapon Destroyed
10	Rotor (-1 MP)	Rotor (-1 MP)
11	Rotor (-1 MP)	Rotor (-1 MP)
12	Rotor (-1 MP) (critical)	Rotor (-1 MP) (critical)

# VEHICLES

## VTOL CRITICAL HIT TABLE

Die Roll (1D6)	Result
1	Cockpit hit, crew killed (VTOL out of action if landed, crashes if flying)
2	Main weapon jams (No fire from largest system for 1 turn)
3	Engine hit
4	Cockpit hit, crew killed (VTOL out of action if landed, crashes if flying)
5	Fuel tank hit (VTOL explodes)
6	Ammo/power plant Hit (VTOL explodes)

### Engine Damage

If a landed VTOL's engine takes damage, the unit cannot move for the rest of the game. If a flying VTOL's engine takes damage over a Clear, Paved, Rough or Building hex, make a Piloting Skill Roll to avoid crashing. If the roll is successful, the VTOL lands in a hex but may not move for the rest of the game. If the VTOL takes damage while flying over other terrain, it automatically crashes.

### Rotor Destruction

If a VTOL's rotor is destroyed while the VTOL is flying, the unit crashes in its current hex and takes falling damage equal to 1 point for every 10 tons that it weighs (rounding up) times the number of levels plus 1 that it fell. VTOLs falling into wooded hexes fall to the ground, not the top of the trees. If the VTOL falls into a Water hex, treat the hex as a Level 0 hex and cut the resulting damage in half (rounding up).

Group the damage into as many 5-point clusters as possible, assigning any remaining points into one smaller group, and determine a hit location for each cluster. Use the appropriate column of the VTOL Hit Location Table as specified by the Facing after a Fall Table in **Movement**, p. 27. Falling damage takes effect simultaneously with all other damage in the phase.

### VTOL Explosions

If any of a VTOL's internal structure, aside from the internal structure of the rotors, takes damage from a crash, the VTOL explodes. A VTOL may also explode as a result of a critical hit, as noted on the VTOL Critical Hit Table. If the VTOL is driven by an internal combustion engine (ICE), then the hex of the crash or explosion catches fire, regardless of the terrain. If the VTOL explodes in a wooded hex, use the **Fire** rules, p. 84 in **Special Case Rules**. Other terrain will burn until the end of the next turn and then go out.

If a VTOL crashes in a Water hex and explodes, the fuel floats on the surface of the water and creates a burning slick. A burning fuel slick in a Water hex will only affect a BattleMech in that hex if the water is Depth 0 or 1. To determine if surface naval vessels occupying a Water hex are affected by a burning

fuel slick in that hex, the player rolls 2D6. The fire destroys the vessel on any result less than 8. A burning fuel slick only affects a submarine in that hex if the vessel is at Depth 0.

Only VTOL explosions may result in fires. Other vehicles, such as tanks and hovercraft, use much less volatile fuels and will not set the hex on fire.

### Physical Attacks against VTOLs

BattleMechs may make normal physical attacks against landed VTOLs. A BattleMech may also physically attack a flying VTOL per the Physical Attacks against VTOLs Table. The first column lists the difference in levels between the BattleMech's hex and the VTOL; to find this number, subtract the BattleMech's hex elevation level from the VTOL's elevation level.

A BattleMech may only make death from above attacks if its Jumping MP equals or exceeds the difference in levels.

Any successful physical attack by a BattleMech automatically destroys the VTOL's rotor, in addition to normal damage.

## PHYSICAL ATTACKS AGAINST VTOLS TABLE

Difference in Levels	Type of Physical Attack Allowed
-1 or lower	None
0	All except Punching
1-2	All except Kicking
3	Clubbing only
4+	None

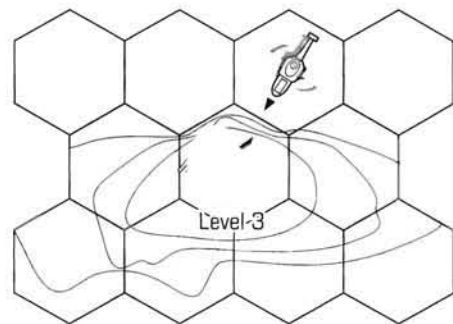

*A BattleMech is on a Level 3 hill facing a VTOL at Level 2. The elevation difference between the BattleMech's hex and the VTOL is -1 (2 - 3). The BattleMech may not physically attack the VTOL. However, if the BattleMech has not moved yet, is jump-capable, and the VTOL has finished its movement, the BattleMech can make a death from above attack. If the VTOL were 1 level higher, the elevation difference would have been 0 and the BattleMech could make any physical attack except a punch.*

## INFANTRY



While BattleMechs and vehicles can be expensive to manufacture and maintain, there is almost no limit to the number of men who can be thrown, willing or unwilling, into battle. Infantry units rarely last long against BattleMechs, but they can sometimes inflict enough damage to turn the tide of battle.

**BattleTech** provides rules for four types of infantry: foot, motorized, jump infantry, and battle armor infantry. Foot and motorized units consist of 28-man platoons. Jump units consist of 21-man platoons. Battle armor units consist of 5-man Points equipped with powered combat suits.

Standard infantry units can be armed with one of five weapons: rifles, machine guns, flamers, portable lasers, or short-range missiles.

All members of a battle armor Point carry an SRM-2 launcher on their backs. The launcher holds four missiles,

enough for two salvos of two missiles each. In addition, members of a Point also carry one anti-BattleMech weapon system, either a regular small laser, a flamer, or a machine gun. All personnel in a Point must carry the same type of anti-BattleMech weapon system because they fire as a combined unit in battle.

The Infantry Units Table illustrates the types of available units, their Movement Points, the number of men in a full-strength unit of each type, and the maximum amount of damage an undamaged unit can inflict on a target.

Before beginning the game, the players should fill out the appropriate record sheet for each unit, indicating the unit's type, weapons, and other statistics. Use this record sheet to keep track of the status of each unit during the game.

### INFANTRY UNITS TABLE

Type	MP	Number of Men	Maximum Damage
<b>Foot Infantry</b>			
Rifles	1	28	7
Machine Guns	1	28	10
Flamers	1	28	10
Portable Lasers	1	28	14
SRMs	1	28	14
<b>Motorized Infantry</b>			
Rifles	3	28	7
Machine Guns	3	28	10
Flamers	3	28	10
Portable Lasers	2	28	14
SRMs	2	28	14
<b>Jump Infantry</b>			
Rifles	3	21	6
Machine Guns	3	21	7
Flamers	3	21	7
Portable Lasers	2	21	11
SRMs	2	21	11
Battle Armor	3	5	See <b>Combat</b> , below

## MOVEMENT

Infantry have no facing and can move in any direction unless blocked by terrain. In general, infantry must pay the same Movement Point costs as other units. However, infantry expend only 1 MP to enter or leave buildings, and may climb up interior stairs of buildings to reach different levels at a cost of 1 MP per level.

Infantry may not move into Depth 1 or deeper water and may only climb 1 elevation level per hex. Jump infantry and bat-

# INFANTRY

the armor move per the jumping rules for BattleMechs (see **Movement**, p. 20).

An infantry platoon counts as one unit for stacking purposes.

## INFANTRY CARRIERS

Infantry may ride inside a vehicle during the course of a game. Any vehicle equipped with cargo space may carry infantry. The carrying unit's capacity is limited to the tonnage of its cargo space. Battle armor Points occupy 1 ton of cargo space. A foot infantry platoon occupies 3 tons of cargo space. A jump infantry platoon occupies 4 tons of cargo space. A motorized infantry platoon occupies 6 tons of cargo space. Do not reduce these tonnages for units that have suffered casualties.

To mount a vehicle during a turn, an infantry unit must start its Movement Phase in the same hex as the vehicle. A platoon may dismount a vehicle only at the end of that vehicle's Movement Phase. A vehicle must spend 1 MP to mount or dismount a platoon. If infantry dismount in the current turn, they may not move or engage in combat in that turn.

A mounted infantry unit does not count toward stacking limits, but a dismounted infantry unit does count toward stacking limits.

Mounted infantry may not fire weapons. If the vehicle carrying infantry explodes during combat, all infantry units mounted in the vehicle are also destroyed. If a vehicle suffers a Crew Killed critical hit result, all infantry mounted in the vehicle are killed. If a vehicle suffers a Crew Stunned result, all infantry mounted in the vehicle are stunned and cannot act or move from the vehicle until the vehicle's crew has recovered. Infantry mounted in vehicles that are destroyed without exploding may move and fire normally in the turn after the vehicle was destroyed.

## MECHANIZED BATTLE ARMOR

Clan battle armor units (made up of Elementals) train to work closely with OmniMechs in combat. Each OmniMech torso features handholds that allow up to 5 battle armor infantrymen to attach themselves to the OmniMech for transport. A Point can mount an OmniMech using the standard rules for mounting and dismounting from conventional vehicles (see **Infantry Carriers**, above). The OmniMech cannot use any torso-mounted weapons when carrying infantry. Infantry takes damage first from all hits on any of the OmniMech's torso locations except the Front Center torso. A randomly chosen trooper takes maximum damage before the OmniMech takes damage from successful attacks. Only one trooper takes damage from any single hit intended for the OmniMech; damage in excess of that required to kill the trooper transfers to the OmniMech.

## COMBAT

Rules for infantry combat are divided into two main categories: standard infantry combat (foot, motorized, or jump), and battle armor combat.

Note that infantry may fire at units occupying the same hex. All damage from such attacks hits the Front side of the target.

## ◆ STANDARD INFANTRY ATTACKS

Use the BattleMech rules for infantry-weapons fire and to-hit procedures, with the following modifications. Infantry have a 360-degree arc of fire, and their weapons have a limited range. Infantry units do not have Gunnery Skill levels or use range modifiers. See the Infantry Base To-Hit Table, below, for the to-hit numbers of standard infantry weapons by range.

### INFANTRY BASE TO-HIT TABLE

Weapon Type	To-Hit Number (Range in Hexes)						
	0	1	2	3	4	5	6
Rifle	2	4	6	—	—	—	—
MG	2	4	6	8	—	—	—
Flamer	3	4	6	—	—	—	—
Laser	2	4	6	8	—	—	—
SRM	3	4	4	6	6	8	8

To calculate infantry to-hit numbers, use the BattleMech rules for line of sight, target movement, and terrain modifiers. However, infantry is not subject to the modifiers for attacker movement.

The amount of damage that a standard infantry platoon can inflict is based on its current number of men and the type of weapons with which it is armed. Consult the Infantry Record Sheet to determine how much damage each type and strength of unit can inflict. For example, a full-strength rifle platoon inflicts 7 points of damage each time it successfully attacks, while an 11-man laser platoon does 6.

Group standard infantry damage to targets into 5-point clusters and apply in the same fashion as LRM damage.

## DAMAGE TO STANDARD INFANTRY

Standard infantry platoons take damage in the same manner as 'Mechs; attackers fire on infantry as normal units using appropriate modifiers, and infantry units take damage equal to the Damage Value of the weapon. As damage is taken, mark off the boxes indicating troopers on the platoon's record sheet, left to right, one for each Damage Point inflicted.

Unarmored infantry hit while in Clear terrain (no terrain modifiers for their hex) suffer twice the normal damage, even if mounted on another unit.

When a standard infantry platoon takes a hit from a vehicular or BattleMech-mounted machine gun, roll 2D6. The result is the damage inflicted on the infantry platoon. Double this damage if the infantry platoon is in Clear terrain.

Machine gun-equipped battle armor units that fire on an unarmored infantry platoon should roll 1D6 for each successful hit according to the Battle Armor Direct Fire Table. Add the die roll result for each hit to create a running total. This total is the damage inflicted on the unit. Double this damage if the infantry platoon is in Clear terrain.

# INFANTRY

WOLFNET ARCHIVE FILE: 44398-TJ9-10/06/51

Excerpted from the Dark Nebula post-battle report of Star Captain Christopher Folkner, commander of the Jade Falcon JumpShip *Hawk-Eye*

The Grand Council made a serious mistake when they created the freebirth unit Wolf's Dragoons and sent them into the Inner Sphere. In my opinion, most of our trouble fighting the Houses stems from the Dragoons' betrayal of our culture and methods. Clearly, the freebirth brothers Jaime and Joshua set into motion a force even they could not control when they approved the creation of the thoroughly unorthodox Cranston Snord's Irregulars.

The Irregulars earned their reputation as a gang of "thieves and treasure seekers" by taking as their main mission the search for lostech and other Star League artifacts. Enemy commanders often underestimated the Irregulars' true prowess, and this allowed the unit to survive and grow into a hardened, elite cadre of warriors.

The Irregulars' greatest find, and our greatest loss, was their discovery of a hidden Star League naval base in the depths of the Dark Nebula in the former Lyran Commonwealth. When the Irregulars traced a cache of star charts and other information to the planet Apollo in our occupation zone, they boldly retrieved it by using our own rules of engagement to their advantage. We forced them to abandon one crate of information, which allowed us to determine their goal and follow them to Camelot Command. The old men allowed to fight this freebirth unit failed even to die honorably, in the end giving up the right to the base and allowing themselves to be captured as isorla.

Now styling themselves Clan Snord, in blatant disregard of all Nicholas Kerensky lived and died for, the motley collection of dezgra Clan warriors and freebirths commanded by Rhonda Snord devotes all its efforts to protecting the non-functional naval construction facility and annoying us with raids.

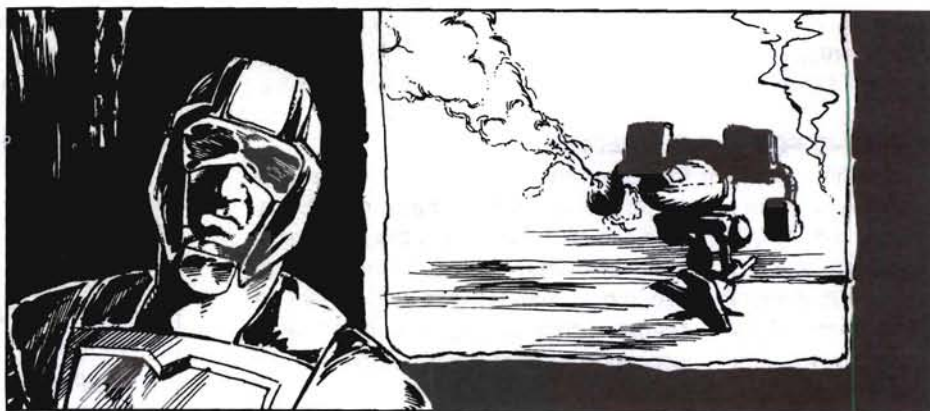

## ◆ Infantry in Buildings

Because buildings block line of sight, units outside a building cannot fire directly at infantry (standard or battle armor) inside a building and must fire at the building instead. Damage done to buildings affects the infantry units inside according to the Infantry Damage in Buildings Table.

Use this table only when damage is intentionally inflicted on the building from a weapon or physical attack, or from a BattleMech or vehicle moving into or out of a building containing infantry. For damage to battle-armored troops inside a building, group the damage into 5-point clusters and roll 1D6 for each cluster to determine hit location (see Damage to Battle Armor).

### INFANTRY DAMAGE IN BUILDINGS TABLE

Building Type	Damage to Infantry Is:
Light	75% of damage to building
Medium	50% of damage to building
Heavy	25% of damage to building
Hardened	None

If a BattleMech is adjacent to an infantry unit occupying a building, all attacks, weapons fire, and physical attacks must be directed against the building rather than the unit itself. If the BattleMech is inside a building and in the same hex as an infantry unit, it may make a weapon attack against that unit, or fire at the building, or make a direct physical attack against the unit.

*An Archer wishes to attack an infantry unit hiding in a Medium Building, and so the 'Mech must attack the building rather than the infantry. The Archer inflicts 20 points of damage on the building, reducing its CF by 20. Ten points of damage (50 percent of damage to building) affect the infantry unit inside.*

## ◆ BATTLE ARMOR ATTACKS

When a Point of battle armor attacks, it fires as a single unit. In any combat round, the Point may fire twice, once with SRMs and once with its second weapon (small laser, flamer, or machine gun). These attacks use all range and line-of-sight restrictions appropriate for the weapon. Note that battle armor small lasers are considered to be standard Inner Sphere models, not ER or pulse lasers. All attacks against units in the same hex as the battle armor unit are considered to be at a Range of 1. Battle armor units have a 360-degree arc of fire.

# INFANTRY



All battle armor attacks have a Base To-Hit Number of 4. Calculate the modified to-hit number using the standard rules, modifying the number for defender movement, terrain, and all other appropriate modifiers. As with standard infantry, battle armor need not modify the to-hit number for attacker movement.

If a battle armor unit makes a successful SRM attack, roll 2D6 and consult the Battle Armor Missiles Table to determine the number of missiles that hit. Each hit inflicts 2 points of damage on the target. Determine a separate hit location for each missile.

## BATTLE ARMOR MISSILES TABLE

Dice Roll (2D6)	Point Members Active (Number of Missiles Fired)				
	1 (2)	2 (4)	3 (6)	4 (8)	5 (10)
2	1	1	2	2	3
3	1	2	2	3	3
4	1	2	3	3	4
5	1	2	3	4	6
6	1	2	4	4	6
7	1	3	4	5	6
8	2	3	4	5	6
9	2	3	5	6	8
10	2	3	5	7	8
11	2	4	6	8	10
12	2	4	6	8	10

When an anti-BattleMech small laser, flamer, or machine gun attack hits its target, roll 2D6 and consult the Battle Armor Direct Fire Table to determine the number of troopers in the Point who scored a hit. Each trooper who hits inflicts normal damage for the weapon. Determine a hit location separately for each hit.

If the attacker uses a machine gun against a standard infantry platoon, determine the amount of damage by rolling 1D6 for each hit and adding the results in a running total.

Note that battle armor-equipped units are highly trained, elite troops and are automatically capable of delivering anti-BattleMech attacks as described in **Anti-BattleMech Infantry**, p. 75 in **Special Case Rules**.

## BATTLE ARMOR DIRECT FIRE TABLE

Dice Roll (2D6)	Point Members Active				
	1	2	3	4	5
2	1	1	1	1	1
3	1	1	1	2	2
4	1	1	2	2	2
5	1	1	2	2	3
6	1	1	2	2	3
7	1	2	2	3	3
8	1	2	2	3	4
9	1	2	3	3	4
10	1	2	3	4	4
11	1	2	3	4	5
12	1	2	3	4	5

## DAMAGE TO BATTLE ARMOR

When a unit attacks a Point of battle armor, the attack strikes the Point as a whole. Use all standard modifiers. In addition, BattleMechs and vehicles must modify their to-hit numbers for battle armor attacks by +1 to account for the spread-out formation and tactics of battle armor units.

On a successful attack against battle armor, roll 1D6, rerolling a 6. The result indicates which one of the troopers takes damage from the hit, rerolling hits on destroyed troopers. Treat long-range missile fire against battle armor as for BattleMechs; each five missiles that hit the unit strike a different, randomly selected trooper. Each weapon, SRM, or cluster of LRMs will only damage the trooper struck; excess damage is wasted.

Each suit of battle armor has an Armor Value of 10 points, plus an additional point of damage that represents the Elemental trooper inside. To inflict damage on the trooper, treat the 11th point of damage as "armor" occupying a single "location." If all 11 points of armor are destroyed, the trooper inside the battle armor is out of action.

## ◆ INNER SPHERE BATTLE SUITS

The Clans developed their battle armor in the middle of the 29th century, and they immediately began using selective breeding techniques to develop a caste of Elemental pilots with the size, strength, and agility to make the most effective use of battle armor. The Successor States have begun fielding their own versions of these suits, but Inner Sphere infantry lack the physical development to use them as effectively as their Clan opponents. To reflect this fundamental inequity, each Inner Sphere battle-suit unit begins the game with only 9 points of armor, plus one additional point that represents the trooper inside. Inner Sphere battle suits do not carry the heavy SRM launchers, and are armed with only one anti-BattleMech weapon. In addition, Inner Sphere battle-suit units rarely organize into Points, and may contain anywhere from one to five soldiers at the start of battle.

## SPECIAL CASE RULES

The **Special Case Rules** section offers detailed rules to resolve specific, strategically important situations that players may want to play out as part of their game. Players can use these rules to simulate the effects of artillery, minefields, fire, gun emplacements, hidden units, and other tactical advantages. This section also provides simplified rules for incorporating air assets into **BattleTech** scenarios, based on the AeroBattle rules presented in **BattleSpace**.

All players should review the special-case rules and agree on those to be included in their game before beginning play.

### ◆ AEROSPACE SUPPORT

The BattleMech may be the king of the battlefield, but even that powerful machine must fear the firepower of fighters. Though more fragile than their ground-based opponents, most fighters carry powerful weapons sufficient to cripple or destroy a ground vehicle or 'Mech, and an intelligently used fighter unit can destroy a much larger ground force.

These rules offer a simplified version of the AeroBattle rules presented in **BattleSpace**. Players who own that game or **AeroTech** can use those rules to more comprehensively incorporate aerospace units into **BattleTech** games, including dogfighting and DropShip, JumpShip, and WarShip combat. The following rules allow those players who own neither game to include the strafing, striking, and bombing attacks of fighters in their **BattleTech** campaigns.

### GAME SET-UP

The number and type of fighters available to each side is normally determined by the scenario being played, assigned in much the same way as artillery support and minefields. Players may also agree to determine aerospace force availability some other way before play begins.

Generate Piloting Skill levels for fighter pilots using standard **BattleTech** rules. These aerospace support rules do not require Gunnery Skill levels.

If players have access to **AeroTech**, **BattleSpace**, or the appropriate **Technical Readouts** or **Record Sheets** books, they may use the fighter profiles in those products with these rules. Otherwise, players can easily generate the required abilities for fighters using the following guidelines.

#### Simplified Fighter Construction

A player must first choose a weight class for each fighter he intends to build.

**Light** fighters carry 25 points of fuselage armor, can mount up to 10 tons of weapons and equipment, and may carry up to 5 units of bombs.

**Medium** fighters have 50 points of fuselage armor, can mount up to 20 tons of weapons and equipment, and may carry up to 10 units of bombs.

**Heavy** fighters carry 75 points of fuselage armor, can mount up to 30 tons of weapons and equipment, and may carry up to 15 units of bombs.

Next, choose the weapons and equipment the fighter will carry. For the purposes of these rules, all weapons are considered to be forward-firing and the player need not specify locations for any item. Players may choose any items available on the Weapons and Equipment Tables, p. 104, as long as the total tonnage does not exceed the weight allowed for the craft. The fighter must carry one ton of ammunition for every weapon that requires ammo.

This simplified design system does not require players to assign each fighter heat sinks, control components, and other such items. This system assumes that every fighter can safely fire all of its weapons during each attack.

### FIGHTER MOVEMENT

These rules simplify the movement of fighters to a sequence of attack runs over the **BattleTech** mapsheets in play.

#### Launch and Approach

Attacking fighters will normally approach a **BattleTech** mapsheet from space, while defending fighters will usually be stationed at airbases on the ground near likely targets. All fighters begin the game off the **BattleTech** mapsheets where the scenario is being played, at a distance expressed in turns of flight and in a direction determined before play begins. Fighters usually approach the map from behind their ally forces. This off-map position may be defined by the scenario or mutually determined by the players.

The specific turn in which players may activate their fighter support may be specified by the scenario being played or mutually determined by the players. Fighter units always begin movement in the End Phase.

Once fighters are activated, they approach the **BattleTech** mapsheets for a number of turns equal to their distance from the mapsheets. At the end of that time, the fighters arrive at their target mapsheet at the end of the Movement Phase.

*The defending player has a squadron of fighters stationed 2 turns off his side of the mapsheet. In Turn 3, he activates his fighters to launch during the End Phase. The fighters spend Turns 4 and 5 approaching the battle. At the end of the Movement Phase of Turn 5, the fighters arrive above the BattleTech mapsheets from the direction of the defender's side of the board.*

#### Attacking

When the fighters arrive over the mapsheet, they may attack units on the board during the Weapon Attack Phase but are also subject to return fire. Every fighter, regardless of the type of attack it decides to make (and even if the fighter decides

## SPECIAL CASE RULES



## SPECIAL CASE RULES

WOLFNET ARCHIVE FILE: 33321-GN4-54/5/7

Excerpted from a ROM agent report to Word of Blake headquarters on Gibson

Every day I spend here on Utrecht observing the Ghost Bears only proves our beloved Myndo Waterly's true brilliance. Her plan to use the Clans like a knife against the Inner Sphere to excise the cancer of the Successor Lords' political infighting remains as valid as the day she conceived it. We may still succeed in recreating the Star League according to Jerome Blake's vision.

Though other Clans feel no great respect for the Ghost Bears, and this Clan holds the narrowest strip of worlds conquered by the invaders, they took those worlds without assistance, unlike Clans Jade Falcon and Smoke Jaguar. The Ghost Bears wrested worlds from both the Free Rasalhague Republic and the Draconis Combine, and won a marginal victory in the battle of Tukayyid. Further, the Ghost Bears occupy several worlds we know to be of military importance.

The following points say that we might influence Clan Ghost Bear to join their efforts against the Inner Sphere to ours. First: they owe loyalty to the Clan way of life, not to the other Clans. If we convince them that we can give them an advantage in reaching Terra, we have given them a powerful incentive to fall in with our plans. Second: they appear to be holding themselves aloof from the infighting that occupies the other Clans. They pit themselves only against the inferior Inner Sphere forces on their borders, and so keep themselves and their equipment in better repair. Third: they have proven themselves capable of adapting their tactics to suit the task at hand, and so would be flexible enough to work with our advisors and/or troops.



not to attack), arriving on the board must nominate a line of hexes over which it will pass, called the "attack line." This row must form a straight line and must lie directly along the craft's direction of travel.

The attack line determines which hexes the fighter may attack and which ground vehicles may fire back (see **Return Fire**, p. 75).

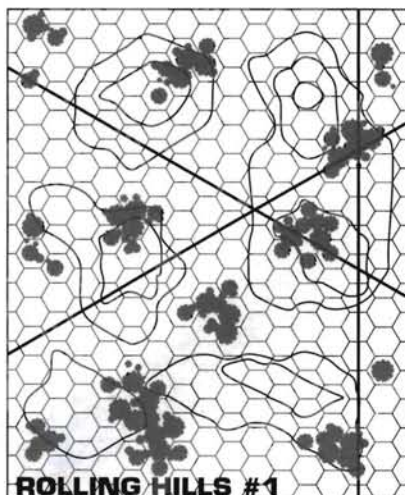

ROLLING HILLS #1

LEGAL

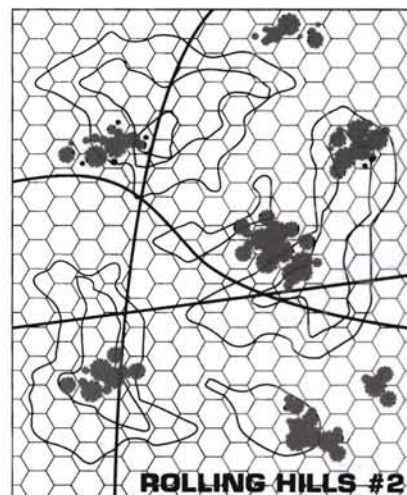

ROLLING HILLS #2

ILLEGAL

### Second Attacks

After making its first attack, a fighter may disengage (see **Disengaging**, below) or turn around and make a second attack. Turning around takes 2 turns, and so a fighter will be in position for its second attack at the end of the second Movement Phase following the Weapon Attack Phase in which it launched its first attack. A fighter making a second attack always approaches the map from the same direction as for the first attack, though it may designate a different attack line.

*The fighter from the previous example chooses to turn around and strafe the battlefield a second time. It spends all of Turn 6 turning around, and arrives on the map from the same direction as before at the end of Turn 7's Movement Phase.*

### Disengaging

A fighter may choose to disengage after its first attack against ground units rather than making a second attack. Fuel and ammunition restrictions, however, require that fighters disengage and return to friendly bases after a second attack. Fighters cannot attack three times without refueling and rearming.

Fighters that disengage are considered out of the game, as the time required to rearm and refuel is far longer than the length of a standard **BattleTech** scenario.

### FIGHTER ATTACK TYPES

Fighters can make three types of attacks against ground targets. The most common form of attack is the strafing run, in which the craft uses energy weapons to attack a "line" of ground hexes. The next most common is the strike, in which a craft targets all its weapons on a single vehicle or building. The least common form of attack, bombing, is also the most deadly. A good pilot can deliver several tons of ordnance into a relatively small area and cause extreme damage.

To apply damage to targets from strafing and striking attacks, determine the total damage and group that result into as many 5-point clusters as possible, assigning any remaining points of damage to a smaller cluster. Determine a hit location for each

## SPECIAL CASE RULES

cluster using the standard Hit Location Tables, using the side of the map from which the fighter entered for the direction of the attack. For example, if a fighter enters the map on the side that the target BattleMech is facing away from, use the Rear column of the BattleMech Hit Location Table to determine damage.

To determine damage and hit location for bombing attacks, see **Damage from Bombs**, p. 75.

### Strafing

Craft flying at low altitude levels may make strafing attacks. A fighter making this type of attack should choose 5 hexes along the attack line as the target hexes. These 5 hexes must form a continuous block and cannot be separated by other hexes.

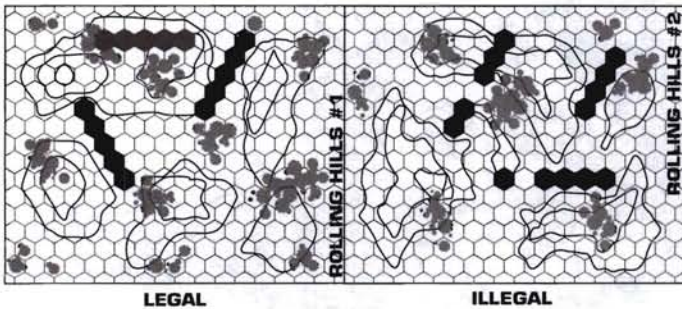

The pilot may choose to fire one, some, or all of its energy weapons during a strafing run (lasers, pulse lasers, or PPCs), and the weapons may strike any ground units (hostile or friendly) in these 5 hexes. The Base To-Hit Number for strafing attacks is 8, modified by the target's movement and the terrain of the hex it occupies. For all weapons fired, make separate to-hit rolls for each unit, friendly or enemy, in the block of 5 hexes.

### Striking

Rather than strafing a row of hexes, a fighter may fire one, some, or all of its weapons, energy and ballistic, at a single target unit or building. The pilot should designate one unit or building located on the attack line as the target of the strike. The craft may fire all its weapons at the target, making a separate to-hit roll for each weapon. The Base To-Hit Number for strike attacks is 8, modified by the target's movement and the terrain of the hex it occupies. If the target of the attack is a building or other immobile structure, subtract 4 from the base to-hit number.

### Bombing

Most fighters are equipped to carry a number of bombs, though the actual capacity depends on the size of the fighter. Each fighter can carry 1 bomb for each 5 tons of the fighter's mass. For example, a 20-ton fighter could carry 4 bombs; a 100-ton fighter could carry a maximum of 20 bombs. However, every 5 bombs (or part thereof) carried adds a +1 penalty to any required Piloting Skill Rolls. These penalties decrease by the same proportions as the fighter drops its payload.

Fighters may carry the following types of bombs, and they may carry several types at once.

**High Explosive (HE):** Each HE bomb inflicts 10 points of damage to any units in the hex of impact.

**Cluster:** Each cluster bomb inflicts 5 points of damage on each unit in the hex of impact and each unit in the surrounding 6 hexes.

**Inferno:** One inferno bomb creates a fire in the hex of impact (even in Clear or Water hexes) which will burn for 30 turns. Use the **Fire** rules on p. 84 to determine the effects of the fire.

**Mines:** Similar to FASCAM submunitions, a mine-type bomb lays a 20-point minefield in the hex of impact and in each of the surrounding 6 hexes. See **Thunder Long-Range Missiles**, p. 121 of **Equipment**, for details.

**Arrow IV:** Fighters may carry either version of the Arrow IV missile. This system can attack any unit on the target map, and it may fire at a target on a nearby mapsheet (up to the Arrow IV's range). Use the standard Arrow IV Missile Artillery System rules on p. 113 of **Equipment**. One Arrow IV missile occupies the space of 5 bombs.

**TAG:** Though not a weapon in its own right, some fighters carry the TAG system in an external pod or built into the fuselage. This allows them to designate (paint) targets for Arrow IV fire and bombing. The pilot must make a to-hit roll against a Target Number of 6 to align the TAG system with the target. The pilot may not make any other attacks while attempting to align the TAG system. Homing Arrow IV missiles may attack a designated target using the rules on p. 113, and will use the BattleMech Punch Location Table to determine the damage inflicted by a successful hit. Friendly fighters making bombing attacks against TAG-designated targets reduce their to-hit number by 2. An external TAG system occupies the space of 1 bomb.

### Delivering Bombs

Fighters can deliver bombs one of two ways. Dive-bombing allows the fighter to precisely target a small area, but may expose the attacker to excessive return fire. Ripple bombing offers less precise targeting, but allows the fighter to spread bombs along a strip of ground, much like a strafing run.

**Dive-Bombing:** A fighter may make a dive-bombing attack against a single hex on the attack line. The fighter may drop one, some, or all of its bombs in the attack. Make a single to-hit roll with a Base To-Hit Number of 6. Do not modify this number for the target's movement or terrain.

If the to-hit roll is successful, all bombs explode in the designated target hex. If the roll fails, the bombs scatter before exploding. On a failed dive-bombing to-hit roll, roll 1D6 for each bomb dropped and consult the Dive-Bombing Scatter Diagram to determine the direction of scatter. Roll a second 1D6 to determine the distance in hexes the bomb rolled from the target hex. The resulting hex becomes the impact hex, and the bomb "attacks" any units in that hex.

## SPECIAL CASE RULES

WOLFNET ARCHIVE FILE: 77654-LT9-32/4/5

From *Brief Candle: The Short Life of Free Rasalhague*, by Callia Monar (ComStar Press, 3055)

The Free Rasalhague Republic gained its independence from the Draconis Combine in 3034, legally granted emancipation from its former master as a way of freeing up several Combine 'Mech regiments and creating a buffer state on the border of the Lyran half of the Federated Commonwealth. After several short battles with those Draconis lords who opposed freedom for the Rasalhague Principality, the Republic became master of its own destiny. In large part because of House Kurita's willingness to let Rasalhague go, relations between the Republic and its former rulers remained friendly.

Rasalhague's independence, however, was fleeting. Invading Clan forces poured into the Republic in 3050, and Clans Wolf and Ghost Bear swallowed up huge chunks of the Free Rasalhague Republic. Not until the Com Guards stopped the Clans' advance on the Republic world of Tukayyid did the remnant of Free Rasalhague gain some respite from unceasing war.

The Clans' depredations reduced the Republic to seven worlds. The morale of the Rasalhagian people is beyond low, and their leaders are faring little better. Among the most painful of Rasalhague's losses to the Clans was the capture of Prince Haakon Magnusson's son and heir, Ragnar; made a bondsman of Clan Wolf, Ragnar refused rescue when the opportunity presented itself.

With only a handful of scraped-together regiments to protect it, the Republic has allowed ComStar to post several divisions of the Com Guards in Republic space. The people of the Republic do not look forward to the ending of the Truce of Tukayyid, a mere ten years away.



# SPECIAL CASE RULES

## DIVE BOMBING SCATTER DIAGRAM

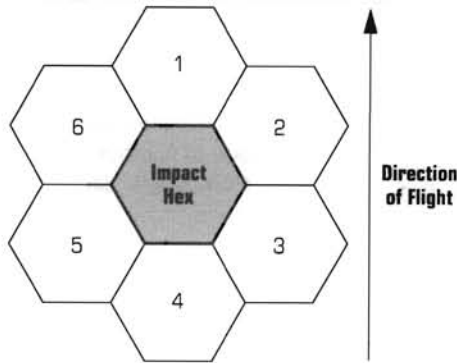

**Ripple Bombing:** Ripple bombing is less precise than dive-bombing but allows attacks against a larger area. Fighters can make ripple bomb attacks from higher altitude levels than other attacks, making return fire against them more difficult (see **Return Fire**, following).

Ripple bombing works in a similar manner to strafing, where a fighter attacks a continuous strip of hexes along the attack line. A fighter may use ripple bombing to attack up to 10 hexes, but the fighter must drop a minimum of 1 bomb and a maximum of 2 in each hex. All targeted hexes must be adjacent to one another. If the craft carries several types of bombs, the pilot chooses which bombs to aim at which hexes.

For example, if a fighter drops only 2 bombs in a ripple attack, the craft can only attack 1 hex (with 2 bombs) or 2 adjacent hexes (1 bomb each). A fighter dropping 10 bombs can target 5 to 10 adjacent hexes.

The Base To-Hit Number for ripple bombing is 9. Do not modify this number for the target's movement or terrain. Make a to-hit roll for each hex targeted.

If a to-hit roll succeeds, the bombs targeted on that hex will explode in the designated area. If the roll fails, the bombs targeted on the relevant hex will scatter before exploding. On a failed ripple-bombing roll, roll 1D6 and consult the Ripple Bombing Scatter Diagram for each bomb targeted on that hex to determine the direction of scatter. Roll 1D6 again to determine the distance in hexes the bomb rolled from the target hex. The resulting hex becomes the impact hex, and the bomb "attacks" any units in that hex.

## RIPPLE BOMBING SCATTER DIAGRAM

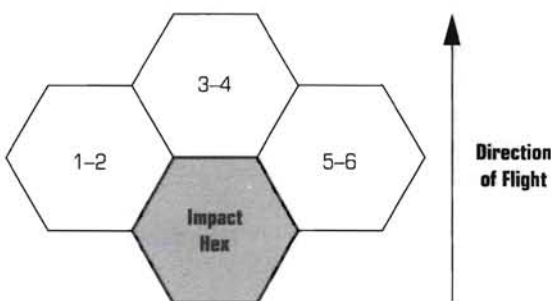

## Damage from Bombs

Group the damage inflicted by bombs into 10-point clusters. Targets in the hex of impact will take damage as if punched in the front/rear. For purposes of determining hit location, roll 1D6. On a result of 1-3, the attack hits the front; on a result of 4-6, it hits the rear of the unit. Cluster munitions also affect units in surrounding hexes. To determine the direction of cluster munitions attacks, treat such attacks as originating in the hex of impact.

## RETURN FIRE

Any vehicle, BattleMech, or gun emplacement (but not infantry or battle-armored troops) on a **BattleTech** mapsheet may fire at any fighter ending its turn over the map, regardless of whether the fighter made a ground attack that turn. Modify the attacker's to-hit roll by +6, and apply the appropriate modifier for attacker movement. Other modifiers such as terrain do not apply. Units lying along the fighter's attack line use a modifier of +4, plus attacker movement.

For attacks against fighters executing ripple-bombing attacks, add an additional modifier of +1 to the to-hit roll to account for their higher altitude. Only weapons with a Long Range of at least 7 can successfully attack a fighter making a ripple-bombing attack.

A unit that fires at an airborne target may not fire at any other unit that turn. The weapons fired must have sufficient range to reach a hex on the fighter's designated attack line (even if the fighter did not attack).

## Damage to Fighters

All damage from return fire is assumed to hit the fuselage of the fighter under attack.

If a fighter's fuselage Armor Value is reduced to 0, the unit is considered destroyed and removed from play.

If a fighter takes 20 or more points of damage during a single turn, its player must make a successful Piloting Skill Roll using a +1 modifier or the fighter will lose control and crash. This roll is further modified by the fighter's bomb payload (see **Bombing**, p. 73). A fighter that loses control and crashes is considered destroyed.

## ANTI-BATTLEMECH INFANTRY

Infantry trained in anti-BattleMech tactics learn to close with a BattleMech, climb it, and plant satchel charges in strategic, vulnerable locations. This dangerous tactic requires highly skilled and dedicated troops, but if successful, it can turn the tide of battle quickly.

Resolve anti-BattleMech attacks in the **Weapon Attack Phase** of the turn.

Note that anti-BattleMech-trained infantry platoons make a rare sight on the battlefield. Thorough training in this specialized technique is time-consuming and expensive, and so players should maintain a standard ratio of 1 anti-BattleMech platoon to 8 standard platoons.

# SPECIAL CASE RULES

WOLFPNET ARCHIVE FILE: 89664-KL9-88/4/2

From *New States in the 31st Century*, by Misha Auburn (Commonwealth Press, 3055)

The small, 17-system state known as the St. Ives Compact formed the Capellan Confederation's St. Ives Commonalty until the Fourth Succession War. The Duchess Candace Liao, daughter of Capellan Chancellor Maximilian Liao and ruler of St. Ives, fell in love with famed Davion spy Justin Allard during the war years. When Justin fled the Confederation, Candace joined him, taking the worlds of the St. Ives Commonalty with her. Upon Candace's marriage to Justin, these worlds became the independent St. Ives Compact.

Though the people of the Compact initially feared absorption by the Federated Commonwealth, as had happened to the short-lived Tikonov Free Republic, Duchess Candace vigorously asserted her realm's independence. St. Ives remains independent to this day, an ally of the Commonwealth through choice rather than coercion.

With tensions increasing in the regions near the Confederation and Davion half of the Commonwealth, Candace has begun to fear for her realm's safety. The current chancellor, Sun-Tzu Liao, has sworn to retake all the worlds the Confederation lost during the Fourth Succession War, including the St. Ives Commonalty. Candace also harbors a secret fear that her nephew Sun-Tzu may strike at her son Kai Allard-Liao, who can legitimately claim chancellorship of the Confederation.



## LEG ATTACKS

Anti-BattleMech infantry platoons and battle armor-equipped infantry that begin a Weapon Attack Phase in the same hex as a BattleMech may choose to attack the BattleMech's legs instead of making a standard weapon attack. During leg attacks, infantry climb the BattleMech's legs and plant explosive charges in its joints to damage the actuators. Modify the infantry unit's base to-hit number as normal for movement and terrain, and subtract if the BattleMech is prone or immobile.

If the unit making a leg attack also uses the **Pointblank Shots from Hidden Units** rule (see **Hidden Units**, p. 89), do not modify the to-hit number for movement or terrain.

The base to-hit number is based on the number of men currently active in the unit. The more men, the greater the chance of success. Use the Leg Attacks Table to determine the base to-hit number.

If the to-hit roll is successful, the attacker rolls 1D6. A result of 1–3 means the attack hit the left leg, and a result of 4–6 means the attack hit the right leg. If one leg is destroyed, the attack automatically damages the other leg. The attacker then rolls 2D6 and consults the Determining Critical Hits Table. If the result is 7 or less, the leg takes 4 points of damage. If the attack results in one or more critical hits, resolve those normally.

### LEG ATTACKS TABLE

Men in Platoon	Battle-Armored Troopers Active	Base To-Hit Number
28–22	4–5	4
21–16	3	7
15–10	2	10
9–5	1	12
4–1	—	No attack possible

## SWARM ATTACKS

Swarm attacks represent the boldest and most dangerous attacks that infantry can perform against a BattleMech. A unit making a swarm attack rushes a BattleMech, grappling and climbing it, and then inflicts damage against the MechWarrior or the upper areas of the BattleMech the next turn.

Anti-BattleMech infantry platoons and battle armor-equipped infantry that begin a Weapon Attack Phase in the same hex as a BattleMech may choose to swarm the BattleMech, rather than use their weapons or attack its legs. Find the infantry unit's base to-hit number in the Swarm Attacks Table and modify it for movement and terrain, and by an additional –4 if the BattleMech is prone or immobile.

If the unit making this attack also uses the **Pointblank Shots from Hidden Units** rule, do not modify the to-hit number for movement or terrain.

### SWARM ATTACKS TABLE

Men in Platoon	Battle-Armored Troopers Active	Base To-Hit Number
28–22	4–5	7
21–16	1–3	10
15–1	—	No attack possible

## SPECIAL CASE RULES

The swarm attack to-hit roll determines only if the infantry manages to gain secure footholds on the BattleMech. The infantry unit does not inflict damage on the BattleMech during either Combat Phase of this turn.

### Fighting Off Swarm Attacks

If the infantry successfully swarms a BattleMech, the BattleMech can try to remove the swarming unit by using its arms during the Physical Attack Phase of the turn. The BattleMech can make a modified punch by making up to 2 Piloting Skill Rolls (one for each arm), adding a +4 modifier and any modifiers for damage or construction normally applied to a punching attack. A successful punching attack forces the infantry unit off the BattleMech and back into the hex, and the unit takes damage equal to a punch from that BattleMech. If the punching attack is unsuccessful, the BattleMech damages itself in the attempt to get rid of the infantry and must take punching damage from the appropriate arm (rather than falling from the failed Piloting Skill Roll). Roll 1D6 and consult the Front column of the BattleMech Punch Location Table to determine the location of the damage. If a BattleMech makes 2 punches, one may be successful and the other may fail. If the player declares that the 'Mech will make 2 punches, both must be resolved, even if the first is successful.

During the Movement Phase of the following turn, infantry units that have not been shaken off travel with the BattleMech. Jump-capable BattleMechs may attempt to shake off their attackers during the Movement Phase. If the BattleMech jumps, the player makes a Piloting Skill Roll with a +4 modifier upon landing (in addition to any other Piloting Skill Rolls required by the jump). On a successful roll, the infantry unit falls off into the hex in which the BattleMech landed. The infantry unit cannot move or shoot for the rest of the turn, and takes one hit of 11 points of damage.

If the BattleMech enters water of Depth 2 or deeper and the swarming infantry unit is an anti-BattleMech platoon (rather than a battle armor Point), the unit is destroyed. If the BattleMech ends its movement in a hex that is on fire and the swarming infantry unit is an anti-BattleMech platoon (not a battle armor Point), the infantry fall off. The infantry unit's player rolls 2D6. On a result of 8 or more, the infantry are destroyed. If the infantry unit survives the fall into the burning hex, it cannot move or shoot for the rest of the turn.

If the BattleMech falls (rather than going voluntarily prone) at any time prior to the next Weapon Attack Phase, the infantry unit falls off the BattleMech into that hex. The infantry unit cannot move or shoot for the rest of the turn and takes one hit of 11 points of damage. A BattleMech cannot intentionally go prone to roll and shake off its assailants.

### ◆ Swarm Attack Damage

If the infantry unit succeeds in staying on the BattleMech, it may make a normal weapon attack during the Weapon Attack Phase of the turn after it successfully swarmed the BattleMech. SRMs may not be used. All attacks automatically hit. The player

rolls 2D6 and consults the Swarm Hit Location Table to determine the location of the hit.

### SWARM HIT LOCATION TABLE

Dice Roll (2D6)	Location
2	Head
3	Rear Center Torso
4	Rear Right Torso
5	Front Right Torso
6	Right Arm
7	Front Center Torso
8	Left Arm
9	Front Left Torso
10	Rear Left Torso
11	Rear Center Torso
12	Head

Damage from a swarm attack equals the unit's standard weapon damage. Battle armor units apply all damage to one hit location. For example, a full-strength battle armor unit equipped with small lasers will inflict 15 points of damage on one location. Non-armored infantry groups its weapon damage into 5-point clusters and applies it as normal. By its nature, a swarm attack by an anti-BattleMech unit may also result in one or more critical hits. In addition to determining normal damage, the player automatically rolls on the Determining Critical Hits Table, p. 42, even if no internal structure took damage in the attack.

Infantry units can continue to make weapons attacks on the BattleMech per the swarm attack rules in subsequent Weapon Attack Phases until the BattleMech is destroyed or manages to shake off the attacking unit.

## ARTILLERY

Players may decide to assign off-board indirect artillery to one or both sides during the game set-up. In this case, modify the normal sequence of play as follows:

Initiative Phase  
Targeting Phase  
Movement Phase  
Reaction Phase  
Off-Board Attack Phase  
Weapon Attack Phase  
Physical Attack Phase  
Heat Phase  
End Phase

### GAME SET-UP

Prior to placing their units on the mapsheet, players should determine the relative location of off-board artillery. Normally,

## SPECIAL CASE RULES

WOLFNET ARCHIVE FILE: 22097-GH6-43/5/8

Intercepted transmission of the private correspondence of Jeremiah Rose, leader of the Black Thorns

Houston, Borghese  
23 July 3055

Master Technician Cornelius Rose  
Tara, Northwind

Greetings Father,

Rianna insisted that I write to inform you that your two children remain alive and well, as do the Black Thorns. Despite their best efforts, the Jade Falcon units on Borghese were unable to defeat the Thorns and finally gave up the fight. Federated Commonwealth troops arrived days ago to garrison the planet, and we will soon be leaving this place.

My sister and fellow officer still voices concern that her decision to accompany my fledgling mercenary unit may have created an unbreachable wall between you two, but I have assured her you would not let such a tragedy occur. Though you may disagree with her choice, I can assure you that Rianna has proved herself in battle, and I believe you would be justifiably proud if you had witnessed her *Phoenix Hawk* in action. She fought with the true spirit of a Highlander, if you would permit me to make such a judgment, and I sincerely hope that any animosity that exists between us would not prevent you from voicing the pride you should rightly feel in her.

Finally, I apologize if it seems I have proved your admonition to the Assembly of Warriors wrong. "Right plan, wrong leader"—the words still linger in my memory, as does your admonition to the kinsmen who might have accompanied the Thorns. But I will leave such judgments to others.

Jeremiah Rose, Commander  
Black Thorns

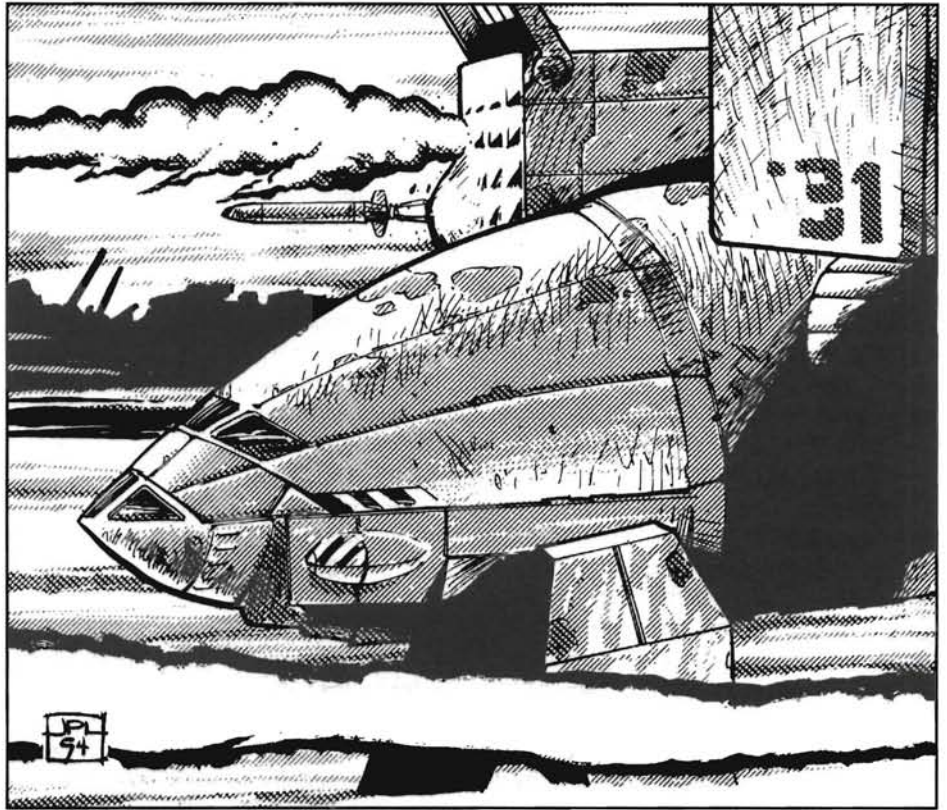

off-board artillery sets up behind the area the onboard friendly forces will occupy. For example, if the friendly forces set up on the north side of the map, the off-board artillery sets up north of the map. Designating a specific location for artillery is important because hit locations on BattleMechs and vehicles are determined by the direction from which the artillery fire arrives. If the target BattleMech is facing north, for example, and the artillery arrives from the north, then the unit takes damage as determined on the Front column of the BattleMech Hit Location Table.

Players must also determine the artillery's distance from the map, expressed in units of 500 meters (the length of one **BattleTech** mapsheet). Keeping in mind the following considerations, players may place an off-board artillery piece any distance from the mapsheet up to its maximum range (see Artillery Table, p. 80). The further away from the map an artillery piece is placed, the longer it takes for its shells to reach its target. The closer the piece is placed to the scene of the battle, however, the greater the likelihood that its position will be overrun and the weapon destroyed or captured if the battle goes against that side. If the players cannot decide on a range, position the artillery at a distance of half its maximum range from the battlefield.

Before beginning play, the player using artillery may designate up to 5 hexes on the battlefield map as artillery targets. Artillery fire on a designated hex automatically hits.

### TARGETING

During the Targeting Phase, a player with off-board artillery may select and record the map hex numbers that he wishes his artillery to fire on that turn. Off-board artillery fire can only be directed at hexes, not individual targets. Players may direct artillery fire at hexes not under the direct observation of a friendly unit; however, this fire may not be adjusted (see **Adjusting Fire**, p. 79). Each artillery piece that a player controls may target a different hex. Record the turn in which each piece fired, each target hex, and the turn in which each fired shell will land. The turn in which a shell will land equals the current turn number plus the shell's time in flight, as shown on the Shell Flight Table.

# SPECIAL CASE RULES

## SHELL FLIGHT TABLE

Distance from Battlefield (in mapsheets)	Time in Flight (in turns)
1 - 2	1
3 - 4	2
5 - 6	3
7 - 8	4
9 - 10	5
11 - 12	6
13 - 14	7
15 - 16	8
17 - 18	9
19 - 20	10

In a mobile battle, artillery that is set up relatively distant from the engagement and not designated to a specific hex offers little chance of doing any effective damage.

During the Off-Board Attack Phase, players announce artillery rounds due to land in that turn and resolve the effects of their fire. Artillery fire may or may not land in the targeted hex. Except for designated artillery fire, to determine whether or not an artillery attack hits its target hex, use a Base To-Hit Number of 11 and apply the appropriate modifiers from the Artillery Modifiers Table.

## ARTILLERY MODIFIERS TABLE

Condition	Modifier
For each point of Gunnery Skill less than 4 possessed by the gunner of the artillery piece.	-1
For each point of Gunnery Skill greater than 4 possessed by the gunner of the artillery piece.	+1
For every 2 points of Gunnery Skill less than 4 possessed by the observing unit (fractions rounded down).	-1
For every 2 points of Gunnery Skill greater than 4 possessed by the observing unit (fractions rounded down).	+1
Adjusting fire: for each previous shot fired at the target hex by the artillery unit (see <b>Adjusting Fire</b> , below).	-1

Roll 2D6. If the result equals or exceeds the modified to-hit number, the round hits the target hex; otherwise, the shot scatters. To determine where the scattered shot lands, roll two dice. The result of the first die determines the direction of the scatter per the Scatter Diagram below, and the result of the second die represents the distance away from the target hex (in hexes) that it lands.

Once an artillery unit hits its target hex, it automatically hits that hex thereafter.

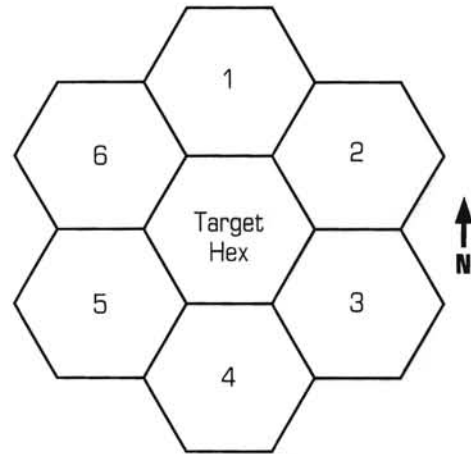

**SCATTER DIAGRAM**

### Adjusting Fire

The player manning an artillery piece may attempt to adjust subsequent fire to home in on its target hex by noting how far off from the target hex and in which direction his shot landed. If the target hex was in the LOS of a friendly unit with Gunnery Skill at the end of the Movement Phase of the turn in which the piece fired, and the same friendly unit has the target hex in its LOS in the turn in which the shell arrives, and the artillery piece has not fired at another target hex during the intervening turns, then the piece may adjust subsequent fire at that hex. Each shell that is observed in this way modifies the to-hit number for that artillery piece by -1, as shown in the Artillery Modifiers Table.

### DAMAGE

All units and structures occupying a hex hit by artillery fire take damage. Group the damage from artillery into 5-point clusters and apply to the target as normal. To determine direction of attack for hit locations, consider the artillery piece to be in the center hex of the map edge beyond which it lies. Thus, if the artillery is located to the north of the mapsheet on which the battle is taking place, resolve hit locations as if the attack originated in the center of the north edge of that mapsheet. See the Artillery Table for the Damage Values of each artillery type against the target and adjacent hexes. Determine damage to adjacent hexes as above, but use the Adjacent Hex Damage Value.

A building in a hex hit by artillery fire absorbs damage equal to its CF divided by 10 before that damage affects any units inside (see **Buildings**, p. 58). Artillery fire against their current hex does not affect units in flight (see **Artillery Flak**, p. 87). Underwater units take normal damage from any artillery shell that hits the hex they occupy. A BattleMech executing a death from above attack is not affected by an artillery shell that hits the BattleMech's current or target hex.

## SPECIAL CASE RULES

WOLFNET ARCHIVE FILE: 00256-FHS-33/4/9

Field report on adjunct Clans—ComStar  
ROM Agent 00341—Classified

Clans Steel Viper, Nova Cat, and Diamond Shark served as adjuncts to the more powerful invading Clans, and so pose less of a threat militarily to the Inner Sphere than do the four leading Clan armies. This does not mean, however, that we can afford to ignore them. Given the scope of our losses on Tukayyid, even the least powerful Clan can still do our forces considerable damage.

Clan Steel Viper, apparently ordered by ilKhan Ulric Kerensky to assist their longtime rivals the Jade Falcons, still smarts with resentment at its subordinate position. The Steel Vipers were given some of the worlds in the Jade Falcon occupied zone, and have attempted to take several more away from the Jade Falcons since 3052. This infighting between the Steel Vipers and the Falcons is to our advantage, and should be encouraged if possible.

Clan Nova Cat is in a similar situation; under orders to back up Clan Smoke Jaguar, the Nova Cats have instead used every opportunity to advance their own cause. During the invasion, they did everything possible to capture worlds for themselves from under the Smoke Jaguars' guns. Shortsighted enough to ignore their ilKhan's warning about carrying adequate ammunition supplies on Tukayyid, they remain unable to see beyond their own present advantage. We may be able to play on this tendency.

Clan Diamond Shark remains something of a mystery. The Diamond Sharks did not participate in the invasion until the battle of Tukayyid, and so hold no Inner Sphere worlds. The fighting on Tukayyid cost them dear, and some believe that the Diamond Sharks have returned to Clan space to lick their wounds. According to other rumors, however, Diamond Shark forces float between several bases scattered throughout the various Clan occupation zones and assist their fellow Clans whenever necessary. I have seen no proof of this rumor, but will continue to look. Sad experience has taught us to take nothing for granted when dealing with these enemies.

### ARTILLERY TABLE

Type	Maximum Range (in mapsheets)	Target Hex Damage	Adjacent Hex Damage
Arrow IV (IS)	5	20	10
Arrow IV (Clan)	6	20	10
Long Tom	20	20	10
Sniper	12	10	5
Thumper	14	5	2

### ◆ SMOKE ROUNDS

Off-board artillery units may fire smoke rounds instead of conventional rounds. A smoke round that hits a hex fills the hex with smoke, and if the artillery piece normally damages adjacent hexes, those hexes also fill with smoke. A smoke-filled hex has the same effect as heavy woods on line of sight and to-hit modifiers, except that smoke only rises 1 level above the terrain it occupies. Under most circumstances, therefore, smoke does not affect BattleMechs.

Smoke from an artillery round disperses in the End Phase of the third turn after it lands.

### ONBOARD ARTILLERY FIRE

While most players use artillery for off-board, indirect attacks, an artillery-equipped unit on the battlefield may be used for direct artillery fire.

To fire a direct artillery attack, the artillery piece must have line of sight to the target hex. Use a Base To-Hit Number of 9. Do not modify the to-hit number for range, target movement, the terrain of the target hex, or for an immobile target. The base to-hit number is modified normally for the attacker's movement and for firing through (not into) woods and for other terrain features. If the attack hits the target hex, the round inflicts standard artillery damage, including damage to adjacent hexes. If the round misses its target, it scatters as described in **Targeting**, p. 78.

Artillery pieces that start the game onboard may also fire indirectly per the off-board artillery fire rules. In this case, the time in flight is 1 turn. Modify the to-hit number for attacker movement during the turn in which it fires.

### ◆ BASEMENTS

Most buildings have basements, a feature that can work to a BattleMech's advantage or disadvantage. For example, a heavy BattleMech might walk through a Light Building and unexpectedly crash through the floor, suffering damage. On the other hand, a BattleMech might be able to use a basement for partial cover. To determine if a building has a basement and the effect of a unit falling into a basement, roll 2D6 and consult the Basements Table. The dice roll result determines the type of basement a building has, if any; the damage from falling into a basement; the effects of a basement on vehicles and infantry; and the appropriate table to use for determining damage location.

Note that published scenario packs may state whether or not and what type of basements buildings contain. Only use the Basements Table if the scenario being played does not provide this information.

A unit falls through the floor and into a basement only if the unit's tonnage is greater than the building's current CF.

# BATTLETECH®

# MINIATURE

# CONVERSION

## PREPARING MINATURES

## PREPARING TERRAIN

## RULES ADJUSTMENTS



**P**LAYERS WISHING TO ADD MORE VISUAL REALISM TO THEIR BATTLETECH GAME CAN USE THE FOLLOWING RULES TO CONVERT THE BOARD GAME RULES INTO A SYSTEM FOR TABLETOP MINIATURE PLAY. WITH BENEFITS OF REAL SCALE, TABLETOP MINIATURE WARGAMING ADDS THREE DIMENSIONALITY TO THE GAME. THE GAME BOARD BECOMES A CONVOLUTION OF HILLS, TREES, ROADS, AND BUILDINGS—A LIVING LANDSCAPE ON WHICH TO PLAN STRATEGIES.

## PREPARING MINIATURES

Players should prepare for miniatures play by assembling (and painting, if desired) their miniatures. These rules assume that players are using Ral Partha BattleMechs, vehicles, and infantry figures.

We recommend that players paint their miniatures with water soluble paints prior to use to add realism and visual excitement to the game. Ral Partha produces an extensive line of acrylic water-based paints that can be used for this purpose, available at most hobby stores, along with brushes and primers.

Miniatures can be painted quickly using the following basic techniques. These do not require a steady hand or even very small brushes. Two good, soft brushes, a No. 000 and a No. 6, will serve the purpose.

Prior to painting a miniature, file off all flash. If any assembly is required, do it now. First, make sure the pieces of the miniature fit together properly. Use a hobby knife or a pin file to clean the joints for a tighter fit, then apply super glue or epoxy to join the pieces together. We recommend a super glue that will fill any gaps, such as Hot Stuff. Glue the antenna (if any) onto the model at this time. For a sturdy antenna mounting, drill a placement hole about 1/8 inch deep using a pin vise and a No. 71 drill bit. Finally, use super glue or an epoxy to attach the unit to a hexagonal base, placing the miniature in the center of the base, facing one of the base's hex sides. To fill the recession on the top of the base, use any of a number of fillers available at hobby shops.

Next, make sure that the miniature is completely clean and dry, then spray on a light undercoating of primer. Allow the primer coat to dry thoroughly before beginning to paint the miniature. This allows the primer to bond firmly with the metal miniature, and will reduce chipping and flaking.

After the miniature is primed, choose a color scheme and begin painting. For basic painting, choose one color—brown, green, or red, for example—and use light, medium, and dark shades to paint the miniature. For example, if you plan to give the miniature a basic color scheme of brown, you might use Autumn Gold, Wood Brown, and Brown from the Ral Partha BattleTech Autumn Colors paint set.

First, use the No. 6 brush to paint the medium shade all over the miniature. Allow the miniature to dry.

Next, mix a wash of the dark shade and apply it all over the miniature. A wash is simply diluted paint. To create a wash, mix three parts water or thinner to one part paint, diluting the paint to the consistency of ink.

The wash will gather in the crevasses and folds of the miniature, darkening its joints and picking out other details. Applying the wash over the entire miniature dulls and stains the medium shade, making the figure look worn. If you prefer for the miniature to look newer, just use a small brush to wash only specific areas of the model.

Next, dry-brush the miniature with the light shade. To dry-brush, simply dip a soft No. 6 brush into the paint, then brush the paint off on a newspaper until there appears to be no more paint left in the brush. Then lightly dust the miniature with the brush. The remaining paint in the brush will highlight the raised portions of the miniature.

Now, use a small brush to add details. In general, just a few will suffice. For example, paint the cockpit canopies a light blue, add a small amount of color to various pieces of equipment, use a wash of black paint around the muzzles of guns or missile tubes, add red to the tips of any exposed missiles, and paint any antenna wires black.

Finally, paint the base green to match the terrain, and sprinkle some landscaping ground cover onto the wet paint and allow it to dry in place.

All playing pieces must be mounted on the center of a hex base.

Orient the front side of BattleMech and vehicle miniatures to one of the hex sides. Mount nine figures for infantry platoons (one officer and eight men carrying the same weapon) on each infantry hex base. Battle armor Points should have five figures mounted onto a hex base. Also paint an ID number on one of the sloping hex sides.

The hex base is very important. It defines firing arcs and is used to determine hit locations, the direction of falls, and the direction that a BattleMech is displaced, in much the same way as the hexgrid on a BattleTech mapsheet.

## PREPARING TERRAIN

Players will also need to construct the terrain their miniatures will fight on. We recommend that the players create a playing surface



PRIMED BATTLEMECH



WOOD BROWN APPLIED



BROWN WASH APPLIED



AUTUMN GOLD DRY-BRUSH APPLIED



DETAILS ADDED

# MINIATURES

that measures at least 40 x 40 inches. That size allows for enough terrain to be added to make the battlefield interesting.

The following suggestions describe ways to represent various terrain features.

## CLEAR

For Clear terrain, simply cover the table with a green felt cloth. Use ground cover of various shades to liven the field. For ground cover, use landscaping materials, such as lichen and grasses of various shapes and coarseness, which can be found at any hobby shop or store selling supplies for model railroading.

## HILLS

Make hills out of green 5/8-inch Styrofoam. Each piece of Styrofoam represents 1 level of elevation. Construct hills of various levels by cutting and shaping successively smaller contour levels and then stacking them on top of each other. The result should resemble a contour map. Each contour of a hill should be cut and shaped individually, then stacked to make hills of various sizes.

When stacking the levels together, leave enough ledge exposed on the lower levels to allow a mounted miniature to easily stand on it. If the exposed area is not large enough for a mounted miniature to stand on, that section represents a cliff face.

The advantage of using Styrofoam is that it is easy to cut to a desired shape and size. If using white Styrofoam, consider painting the hills green and covering the wet paint with model railroad landscaping grasses. Green Styrofoam can be found in almost any floral shop or hobby and craft store, and even in some hardware stores.

## TREES

Hobby and model railroading shops carry a large variety of trees. To create light woods, make a template base (see below) and mount it with a group of trees, spacing them about 3 inches apart. In addition, mount individual trees on bases 2 1/2 inches in diameter. This combination allows you to create a light forest in a specific shape, and to convert it into heavy woods by placing the single trees in among the trees fixed to the larger template.

The template can be made of any material sturdy enough to support the trees. Paint the template the same shade of green as your Clear terrain ground cloth. For a more realistic

look, paint the template and sprinkle landscaping material over it before the paint dries to represent grass.

Another way to create a wooded area is to outline the edge of the forest with lichen, then place individual trees within that border to the density desired. Lichen comes in a wide variety of colors, and so makes great alien terrain.

## WATER

To create rivers, streams, and lakes, use one of the following methods. One method is to cut a thin sheet of Plexiglas to the dimensions desired. For a more realistic effect, paint the underside of the Plexiglas in varied shades of blue. Use darker blues to represent deeper water, starting with the darkest blue in the center of the glass. Some model railroading suppliers sell ready-made plastic sheets of "water" that can be cut to a specific shape. A simpler, less expensive method is to represent water with dark and lighter blue construction paper. However you choose to represent water, make sure the depth levels can be clearly identified.

## ROADS/BRIDGES

Appropriate materials for representing roads and bridges can also be found at hobby and model railroading shops, including simulated road materials ranging from gravel for dirt roads to more polished imitations of macadam and concrete. Use "Z gauge" scaled bridges—these most closely match the scale Ral Partha uses for their BattleTech miniatures. Masking tape and/or brown, black, and gray construction paper work just as well.

## BUILDINGS

Buildings appropriate for BattleTech miniatures play can also be found at hobby and model railroading shops. We recommend products scaled for micro-armor or "Z gauge" scale model railroading. Resin-cast buildings produced especially for micro-armor gaming are also available, as are kits that allow you to fabricate buildings in plaster to your own specifications (these require quite a bit of time and effort).

If the BattleMechs in your game jump a lot, you might prefer buildings with flat roofs. Remember that each 5/8 inch of height represents 1 level of elevation. Mark the Construction Factor (CF) on the bottom of each building model.



UNPAINTED HILL



FINISHED HILL



LIGHT WOODS TEMPLATES



RIVER & HILLS



ROAD & BRIDGE

# MINIATURES



ROUGH GROUND TEMPLATE



SWAMP TEMPLATE

## RUBBLE

You can use anything you have lying around to represent rubble. Broken buildings, pieces left over from making other parts of the terrain, or even other models can be “distressed” using woodworking tools, a soldering iron, and/or a hot knife. Please be very careful using such tools. The result should look like something that was blasted apart or burned down.

## ROUGH GROUND

Construct rough ground using ballast, small bits of lichen, or even twigs and soil. If you glue the material onto a template to define the rough area, it is easy to reuse the terrain.

## SWAMP

We recommend creating a water template colored green, brown, or black to represent murky water. Add small bits of lichen to the template to indicate reeds and tufts of swamp grass. Again, as with water, construction paper of the appropriate colors can be used.

## GRIDDED TERRAIN

Some manufacturers produce terrain that is already gridded into hexes. If using such gridded terrain, use the BattleTech rules described elsewhere in this book as written. You may still want to create some of the terrain suggested above to highlight the various features of your battlefield.

## RULES CONVERSIONS

The following rules conversions make it possible to run BattleTech battles on ungridded terrain. These simple adjustments in no way alter the basics of the BattleTech rules system. They merely adapt those rules to create a grand field of play. Unless otherwise noted, use all standard BattleTech rules.

To play a BattleTech miniatures game, players need tape measures, straightedges, dice, and filled-out record sheets. Before beginning play, set up the table’s terrain in a fashion agreeable to all players. Use landscaping grasses to blend in the cracks between templates, if desired.

## SCALE

In BattleTech, a standard hex is 30 meters across, and 1 level of elevation equals 6 meters. This scale needs to be converted to

inches (or centimeters). If the players have a fairly large playing surface, use a ratio of 1 inch = 10 meters. If using a small playing surface (for example, a dining-room table), substitute a horizontal scale of 1 inch = 15 meters. One advantage to using a 1 inch to 10 meters scale is that the thickness of the Styrofoam used in constructing the hills automatically equals approximately 6 meters.

Players may also use metric measurement. Whenever these rules refer to 1 inch = 10 meters, assume 4 cm = 10 meters. If using a 1 inch = 15 meters scale, assume 4 cm = 15 meters. One level of elevation is 1.5 cm.

Unless otherwise noted in the rules below, when the mapsheet rules specify a certain number of hexes, multiply that number by 3 if using the 1 inch = 10 meters scale. If using the 1 inch = 15 meters scale, multiply by 2. For example, if a skid would result in a BattleMech sliding 3 hexes, move the miniature 9 inches (for the 1 inch = 10 meters scale).

When a full hex is set on fire, or the terrain is converted or full of smoke, measure a circle around a single point on the table. The radius of this circle should be either 1.5 inches (on the 1 inch = 10 meters scale) or 1 inch (on the 1 inch = 15 meters scale). When an event affects a target hex and all adjacent hexes, draw a circle with a radius of 4.5 inches or 3 inches, respectively.

A miniature represents a unit as large as its base. If an effect touches a miniature’s base, that figure is affected. If the effect is fire, that unit is standing in fire. If the effect is smoke, that figure is surrounded by smoke, which makes it harder to hit and also makes it harder for the figure to hit others. If smoke continues for more than 1.5 inches (1 inch in 15-meter scale) beyond the base of a figure and along a proposed line of sight, that LOS is broken.

## MOVEMENT

In miniatures play, a unit is moved a number of inches rather than a number of hexes. To convert a unit’s Movement Points to conform to the 1 inch = 10 meters scale, multiply the unit’s Walking (or Cruising) and Jumping MP by 3. For 1 inch = 15 meters, multiply by 2. For both scales, recalculate the unit’s Running (or Flank) MP based on its new Walking (or Cruising) MP.

*For example, a Marauder’s various Movement Points would be converted as shown using the two scales.*



MADCAT & ELEMENTALS HOLDING A BRIDGE



ENGAGEMENT ON RIVER BANKS

# MINIATURES

## Marauder Movement Points

	BattleTech Rules	Miniatures Rules
	1" = 10m	1" = 15m
Walking MP	4	8
Running MP	6	12
Jumping MP	0	0

The Movement Costs Table shows the conversion for terrain type and physical action.

Note that movement costs for entering terrain are the same as in standard BattleTech, while actions such as standing up and changing elevation, whose MP costs reflect spending time rather than covering distances, are multiplied by 3, or by 2 if using the smaller scale.

Accomplish movement in the same way as in the standard game: players declare whether the unit is standing still, walking, running, or jumping, all of which require a set number of MP. A BattleMech or vehicle can only move directly forward or backward, as normal.

Measure facing changes for BattleMechs and vehicles by how many hexsides the unit turns. To determine this, place a straightedge along one side of the hex base and rotate the unit so that it is facing in the desired direction. Count the number of full and partial hexsides that pass the straightedge. This is the number of hexsides that the unit turned at that point in movement.

*The Catapult wants to turn to the left. The controlling player lays a straightedge along the front of its hex base and the 'Mech is rotated to the left to face the desired direction. The unit turned 90 degrees, and one full and one partial hexside passed the straightedge. This maneuver costs the Catapult 6 MP.*

To move a unit, measure from the front of its hex base. The unit must spend MP for each inch or fraction of an inch of terrain that it moves through. The unit is considered to have entered a terrain type if any portion of its base enters that terrain. (If using templates for terrain, a unit enters terrain if it even partially overlaps the template for that terrain.)

A jumping unit only pays one MP per inch traveled (minimum 3 heat), regardless of the terrain that it passes over.

*The Daishi wishes to move into the center of the light woods template to its right. It moves 4 inches forward through Clear terrain (4 MP), then makes a right turn (3 MP) and moves 3 1/2 more inches forward, 2 of which are in Clear terrain (2 MP) and 1 1/2 inches in the light woods (4 MP). The total movement cost for this maneuver is 4 + 3 + 2 + 4, for a total of 13 MP. Note that even though the Daishi only moved through 1 1/2 inches of light woods terrain, it paid the MP for a full 2 inches of movement.*

## STACKING

Units cannot be stacked in the miniatures game. However, infantry units whose bases are touching a BattleMech's base may engage in anti-BattleMech attacks as described in the Anti-BattleMech Infantry rules. Infantry units may mount a vehicle if their base touches the vehicle's base within the guidelines given in Infantry Carriers, p. 67 of Infantry. When dismounting, an infantry unit may place itself anywhere adjacent to its vehicle.

## FALLS

While aesthetically pleasing, it is best not to lay a fallen BattleMech miniature on its side. Players need to use the 'Mech's base to determine the BattleMech's actual location and orientation for combat purposes and future movement. If players really want to lay their miniatures prone, use a blank hex base to mark the actual location of the BattleMech.

Apply damage from a fall as normal. Remember that each 5/8 inch of a building's height is equal to 1 elevation level (round to the nearest multiple of 5/8" when determining height).

## COMBAT

Resolve combat in the same manner and sequence as in the standard BattleTech game, unless otherwise noted below. Note that when falling, skidding, or being pushed, the orientation of a unit's base indicates the direction that the unit will go.

## Line of Sight

Determine line of sight according to the BattleTech rules. Measure from the center of the attacker's base to the center of the target's base. If the LOS passes over any portion of a template or hill, that terrain lies along the LOS.

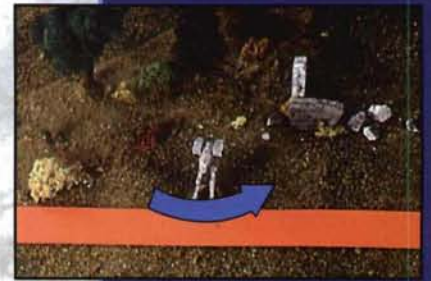

INITIAL FACING



FINAL FACING

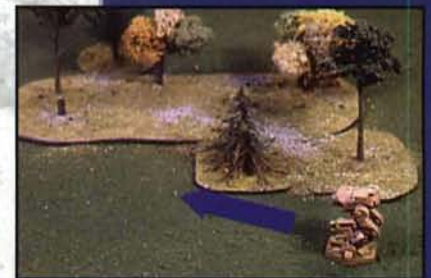

START OF MOVEMENT

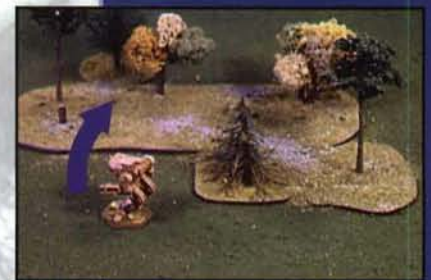

MOVEMENT TO TURNING POINT

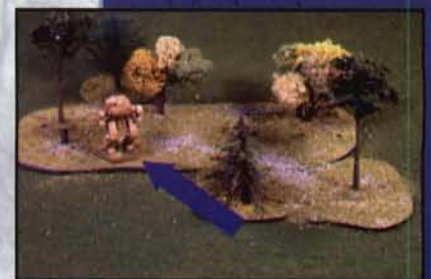

FINAL POSITION

# MINIATURES

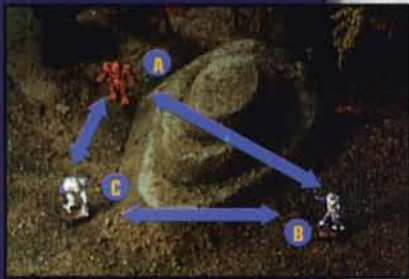

LINE OF SIGHT

Treat each elevation contour of a hill as 1 level. All trees are still 2 levels tall. To determine if trees block LOS, treat every 3 inches or portion thereof of woods as a hex. (Use every 2 inches for the 1 inch = 15 meters scale.)

*BattleMechs A and B do not have a valid LOS to each other, because their LOS passes through a Level 3 hill contour. BattleMechs B and C have a valid LOS to each other, even though their LOS passes over a Level 1 hill contour. Units C and A also have a valid LOS to each other.*

## Firing Arc

Use the unit's base to determine the firing arc, using a straightedge to show the field of fire as in the diagram.

*The Marauder has the Charger, but not the Warhammer, in its forward firing arc. The Warhammer has both the Charger and the Marauder in its forward firing arc.*

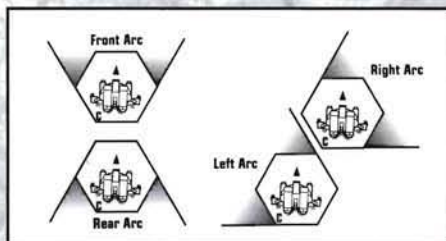

## Range

The change in scale makes it necessary to convert weapon ranges in a similar fashion to movement. Multiply the maximum short, medium, and long ranges for all weapons by 3 to determine the table-top distances. (Multiply by 2 for the 1 inch = 15 meters scale.) For example, an Inner Sphere medium laser would have the following ranges: Short, 0 to 9 inches; Medium, 9 to 18 inches; Long, 18 to 27 inches.

Measure range from the center of the attacker's base to the center of the target's base. If the target is a building, use the center of the building. (For a large building, use a point 1.5 inches into its interior.) If the target is woods, any point on the template can be targeted. Note that if the distance is even a fraction of an inch greater than the maximum distance for a range, then the next higher range applies.



CATAPULT FIRING AT ATLAS

## TARGET MOVEMENT TO-HIT MODIFIERS

(1" = 10 meters)

Target Moved (in inches)	Modifier
0 – 6	None
6.1 – 12	+1
12.1 – 18	+2
18.1 – 27	+3
27+	+4
Jump	+1

(1" = 15 meters)

Target Moved (in inches)	Modifier
0 – 4	None
4.1 – 8	+1
8.1 – 12	+2
12.1 – 18	+3
18+	+4
Jump	+1

## To-Hit Modifiers

Use standard to-hit modifiers except for woods. If using the 1" = 10 meters scale, apply the modifier for 1 hex of woods for every 3 inches (or portion thereof). If using the 1" = 15 meters scale, apply the modifier for every 2 inches (or portion thereof).

*The Catapult is firing at the Atlas through 4 inches of light woods. This counts as 2 Light Woods hexes, giving the Catapult a terrain to-hit modifier of +2.*

Use the Target Movement To-Hit Modifiers Table for the scale of the game to determine the to-hit modifiers for the target's movement.

Note that if the distance is even a fraction of an inch greater than the maximum allowed for a modifier, the next higher modifier is used.

## Attack Direction

Determine the direction of attack normally, substituting the target's base for its hex. Using a straightedge, find the hexside crossed to determine the side on which the unit takes the damage. If the straightedge crosses the intersection between two sides, the defender chooses which side takes the hit.

# MINIATURES

## MOVEMENT COSTS TABLE

Terrain/Action	1" = 10 meters	1" = 15 meters
Clear	1 MP/inch moved	1 MP/inch moved
Road/Paved/Bridge	1 MP/inch moved	1 MP/inch moved
Rough	2 MP/inch moved	2 MP/inch moved
Light Woods	2 MP/inch moved	2 MP/inch moved
Heavy Woods	3 MP/inch moved	3 MP/inch moved
Light Building or Rubble	6 MP	4 MP
Medium Building	9 MP	6 MP
Heavy Building	12 MP	8 MP
Hardened Building	15 MP	10 MP
Water		
Depth 0	1 MP/inch moved	1 MP/inch moved
Depth 1	2 MP/inch moved	2 MP/inch moved
Depth 2	4 MP/inch moved	4 MP/inch moved
Depth 3+	4 MP/inch moved	4 MP/inch moved
Elevation Change		
Mech, VTOL, Sub	+3 MP/level	+2 MP/level
Infantry, Ground	+6 MP/level	+4 MP/level
Facing Change	3 MP/hexside	2 MP/hexside
Dropping to the Ground	3 MP	2 MP
Standing Up	6 MP	4 MP

*The Highlander takes a hit from a large laser carried by the Mad Cat. The Highlander will take the damage on its Right side.*

## Physical Attacks

A unit may only make a physical attack if its base is touching the base of the target unit. In all cases, the bases of units displaced because of physical attacks remain touching the base of their attacker, and both units are moved to reflect the displacement.

BattleMechs that are successfully pushed move 3 inches in the direction of the push (2 inches if using the 1" = 15 meters scale).

An attacker can only carry out a charging attack if the attacking unit has sufficient MP to occupy its target's location. If the charge is unsuccessful, the attacker is displaced to the left or right of the target, but the bases of the two units continue to touch. If the charge is successful, the attacker occupies the defender's location and the defender is displaced in the direction of the attack, but the two bases remain in contact.

*The Mad Cat makes a charging attack against the Highlander. If the Mad Cat is successful, it moves into the Highlander's location and the Highlander is moved back, but its base remains in contact with the Mad Cat's. If the charge fails, the Marauder would move as shown.*

## ARTILLERY

If using off-board artillery, note its target location by writing down the number of inches from each side of a designated corner of the table the round is to land. In other words, use the edges

of the table as the axes of a standard X,Y graph.

Determine scatter by centering a blank hex base on the intended impact point and using the Scatter Diagram in the rules for targeting artillery, p. 79 in Special Case Rules. Remember to multiply the number of hexes scattered by the appropriate scale modifier to determine by how many inches the round goes astray.

In the standard BattleTech game, artillery fire attacks units in the impact hex and in adjacent hexes. Use the Artillery Damage Radius Table to convert this rule for miniatures play. Units within the stated ranges take the points of damage indicated. Determine attack direction from the impact location of the round.

## ARTILLERY DAMAGE RADIUS TABLE

Weapon	Radius			
	1" = 10m		1" = 15m	
	0 - 1.5	1.6 - 4.5	0 - 1	1.1 - 3
Sniper	10	5	10	5
Long Tom	20	10	20	10
Thumper	5	2	5	2
Arrow IV	20	10	20	10



MAD CAT FIRING AT HIGHLANDER



MAD CAT & HIGHLANDER AT START OF CHARGE



FINAL POSITIONS: SUCCESSFUL CHARGE



FINAL POSITIONS: UNSUCCESSFUL CHARGE



MAD CAT CHARGING HIGHLANDER



## SPECIAL CASE RULES

### BASEMENTS TABLE

Dice Roll (2D6)	Effect
2	Double Basement. A BattleMech falls 2 levels. Apply all damage to the legs (use the Front column of the BattleMech Kick Location Table).
3	Basement. A BattleMech falls 1 level. Apply all damage to the legs (use the Front column of the BattleMech Kick Location Table).
4	Basement. A BattleMech falls 1 level (use the Front/Rear column of the BattleMech Hit Location Table).
5	No Basement.
6	No Basement.
7	No Basement.
8	No Basement.
9	Small Basement. Protects infantry from damage, but traps them if the building is destroyed while they are inside. No effect on BattleMechs. Vehicles that fall in cannot get out.
10	Basement. A BattleMech falls 1 level (use the Front/Rear column of the BattleMech Hit Location Table).
11	Basement. A BattleMech falls 1 level head first (use the Front/Rear column of the BattleMech Punch Location Table).
12	Double Basement. A BattleMech falls 2 levels head first (use the Front/Rear column of the BattleMech Punch Location Table).

A vehicle takes normal falling damage when it falls into a basement; use the Front column of the vehicle's Hit Location Table if it moved forward into the basement, or the Rear column if the vehicle reversed into the basement. Any vehicle that lacks flight capability that falls into a basement is considered trapped there for the rest of the game. The trapped vehicle may only fire at targets in adjacent hexes, unless the target is higher than the ground floor of the building the trapped unit occupies. If the target occupies a higher elevation, the attack range increases by 1 hex for each level of elevation of the target above the building hex's terrain.

For example, in order for a trapped vehicle to fire on a target 2 hexes away, the target must be at least 1 level higher than the building's underlying terrain. However, the vehicle occupying the basement cannot be shot at except by units that it can hit. See the Basements Table for additional effects.

### ◆ BATTLEMECH LIFTING CAPABILITIES

In some situations, a BattleMech pilot may want his machine to lift and carry a piece of equipment. Only BattleMechs with functioning hand actuators may pick up an object. To pick up an object, a BattleMech must end its Movement Phase in the same hex as the object, and it may make no weapons or physical attacks that turn. A BattleMech can pick up objects that weigh up to 10 percent of its tonnage. While the BattleMech is carrying the object, it cannot fire any arm or forward-firing torso-mounted weapons, make punching attacks, or use a club; it may make charging and kicking attacks and execute death from above attacks. In addition, the BattleMech suffers the limitations described in **Cargo Carriers**.

### ◆ CARGO CARRIERS

During construction of any vehicle, a player may dedicate specific tonnage to function as cargo space. This tonnage is considered enclosed and protected by the unit's armor. The unit may carry any cargo weighing up to this tonnage without penalty.

A BattleMech or vehicle may also carry unprotected cargo (in slings, strapped to the top, in lightweight containers, and so on) equal to its own tonnage. However, a unit carrying external cargo weighing up to a quarter of its own weight must subtract 3 MP from its Walking/Cruising MP or half of its Walking/Cruising MP (round down), whichever is less. A unit carrying a load weighing more than a quarter of its own tonnage may only move at half its Walking/Cruising MP (round down).

Any successful attack on a unit carrying unprotected cargo also strikes the cargo. If the cargo is infantry, the attacking weapon does 4 times its Damage Value. Determine hit location and damage against the carrying unit as usual; unprotected cargo does not reduce this damage. When the armor that protects the cargo is destroyed, the cargo is destroyed at a rate of 1 ton per point of damage the unit takes.

The hauling unit may drop his cargo during his Movement Phase by expending 1 MP and declaring that he is dumping all his cargo. If the hauling unit is at ground level, the dropped cargo remains in the hex in which it was dropped. If the hauling unit is flying, the cargo takes normal falling damage from landing in the hex above which it was dropped.

### CLEARING WOODS

Units can use heavy weapons fire to clear wooded hexes, though an attempt to do so may set the woods on fire by accident (see **Fire**, p. 84). Woods can be reduced from heavy to light, or cleared of trees completely, though the fallen trees convert the hex to Rough terrain rather than Clear. Though the BattleMechs and vehicles of the 31st century wield awesome firepower, even they cannot alter the terrain of a Rough or Clear hex. No type of small laser, machine gun, AC/2, AC/5, or SRM-2 can be used to clear woods, nor can infantry weapons be used to clear woods.

## SPECIAL CASE RULES

WOLFNET ARCHIVE FILE: 13567-605-45/90/8

From the prologue of *For The Love Of Freedom*, a historical romance by G. Elliotte (Blazing Hearts Press, 3054)

Only the most daring and courageous men and women have ever ventured into the unknown. It was such brave souls who traveled beyond the safe haven of Terra into the infinite reaches of space. As they sought freedom from political oppression, they eagerly embraced a chance to explore new worlds.

The farthest reaches of known space encompass the planets of the Periphery, so called because they lie along the established borders of the Inner Sphere. The first settlers of these far-flung worlds established multitudes of small kingdoms and independent states, many of which still flourish. Other settlements, broken by the unending struggle to survive their harsh environments and defend against aggressions from their neighbors, sank into barbarism or disappeared completely. Still other communities fell in the fierce battle against rule by the Star League, or faded away when that idealistic government self-destructed in a blaze of treachery and egos.

The ranks of the intrepid have included dishonest men as often as honest ones. From its inception, bandits, pirates, and other criminals made the Periphery their base of operations from which to prey upon their honest neighbors and outlying Inner Sphere worlds. Nonetheless, more than one realm has risen above its origins or held its own against privateers to establish a successful society. The Taurian Concordat and Magistracy of Canopus both triumphed over the depths of chaos into which they plunged with the collapse of the Star League. Their leaders have now joined the two nations together, pledging to expand their realms through colonization, rather than military conquest, thereby offering to their citizens the same opportunities to pursue freedom that their forebears enjoyed. Their only serious rival for control of explored space, the Outworlds Alliance, may soon find its own path to economic stability, and then pursue its ruler's true agenda.

The Inner Sphere has ever tried to influence the Periphery states, in subtle ways and bold. Always, the Periphery resisted. Now, threatened on one side by the Clans and on the other by the Successor States, these independent realms must renew their battle for continued existence.

When a player wants his BattleMech or vehicle to clear a wooded hex, he declares that hex as his unit's target during the Weapon Attack Phase. Modify the to-hit number for range and by -4 for a stationary target, and modify the roll normally if firing *through* wooded hexes (but not for firing into or out of wooded terrain). A successful clearing attack converts the wooded hex to the terrain shown in the Terrain Conversion Table.

### TERRAIN CONVERSION TABLE

#### Former Terrain

Heavy Woods  
Light Woods  
All others

#### New Terrain

Light Woods  
Rough  
No change

### ◆ DROPPING TROOPS

Normally, troops enter a battlefield by advancing over ground to the target. In some cases, troops achieve the elements of speed and surprise through an assault drop. Such a maneuver requires troops to drop from a DropShip while it is still in flight, either in space or atmosphere. Dropping troops wear special jump-packs that allow them to descend to the planet's surface in relative safety.

Most often used in scenarios as an alternative method of landing troops on a **BattleTech** mapsheet, complete rules for drops appear in **AeroTech** and **BattleSpace**. This section provides a simplified version of those rules. Note that only BattleMechs and battle armor-equipped infantry may make assault drops.

The player controlling the dropping troops should nominate a hex on the mapsheet in which each unit will land. For 'Mechs, the player makes a Piloting Skill Roll to determine whether the landing was successful. Modify the target number as usual for the unit's current damage. A failed roll means the landing failed and the unit missed its target hex.

A BattleMech that fails its landing will take damage as though it had fallen a number of elevation levels equal to the number of points by which the roll failed (see **Falling**, p. 26 in **Movement**). For example, if a 'Mech with a modified Piloting Skill target of 6 or better rolled a 3, the unit would suffer damage as from a fall of 3 levels. A Piloting Skill Roll for landing that failed by more than 7 means the 'Mech is automatically destroyed.

Because battle armor units have no Piloting Skill and suffer no relevant damage during a drop, simply roll 2D6 for each Point to determine whether the landing succeeded or failed. A result of 4 or better indicates a successful drop. If the result is a 3, each member of the Point suffers 1D6 damage. If the result is a 2, each trooper takes 2D6 damage.

On a failed landing, the unit will also "scatter" 1D6 hexes for every point by which the result falls below the Piloting Skill target. Use the Scatter Diagram for **Artillery**, p. 79, to determine the direction of the scatter. If the Piloting Skill Roll for landing fails by 5 or more, the unit misses the target mapsheet entirely and is considered destroyed for purposes of determining victory in the current scenario (use only if playing an ongoing campaign).

Dropped troops always land at the end of the Movement Phase. They may not fire or otherwise act for the remainder of that turn, but may be fired upon (attacker modifies the to-hit number by +1 for target movement, and also adds the appropriate modifiers for range, terrain, and so on). Landed units function normally thereafter.

## DUMPING AMMUNITION

During the course of a game, a player might wish to dump the ammunition carried by his BattleMech. He accomplishes this by opening the ammo loading doors on the back of the BattleMech and allowing the ammunition to fall out.

During the End Phase of a turn, a player can announce that his BattleMech will dump ammunition during the next turn. The unit may dump any or all of the ammunition it carries, but ammunition must be dumped by location; if any ammo in a location is dumped, all of the ammo in that location must be dumped. Dumping is carried out during the course of the following turn.

When a player announces that his unit will be dumping ammunition, that ammunition is no longer available for use. However, the ammunition is not actually gone from the BattleMech until the End Phase of the following turn. For that one turn, the ammunition remains onboard and subject to the effects of heat build-up and critical hits.

A BattleMech that is dumping ammunition cannot run or jump in that turn. Any hit against the dumping 'Mech on any Rear torso location during the Weapon Attack or Physical Attack Phases inflicts normal damage, but it also causes all dumping ammunition that can explode to do so. (Ammunition can be stored in many different BattleMech locations, but is loaded and unloaded through the Rear torso.)

Ammunition dumped into a hex cannot be exploded or used for any type of attack.

## ◆ EJECTING

The vicissitudes of war occasionally force a MechWarrior to leave his BattleMech in a hurry, and this is best accomplished by using the cockpit ejection system. When the pilot fires this system, explosive bolts allow the cockpit canopy to separate from the 'Mech, and the pilot rockets away from the now-disabled BattleMech. The ejecting MechWarrior usually lands in the hex immediately behind the abandoned BattleMech, though some BattleMechs eject their pilots forward. All BattleMechs are equipped with sensors that detect impending ammo explosions and automatically eject the pilot before the ammo explodes. Because the advent of CASE (described in **Equipment**, p. 115) made it possible for a BattleMech to survive an ammo explosion, many MechWarriors disable the auto-eject feature. Players should decide before each battle and note on the record sheet whether or not the pilot disables his 'Mech's auto eject.

During the Movement Phase, a player may choose to have the MechWarrior eject rather than move. If the auto-eject function is operational, the pilot can also eject at the end of any Attack Phase in which an ammo explosion takes place.

Ejecting from a 'Mech can be dangerous, and the pilot may suffer damage upon landing. The pilot must make a successful Piloting Skill Roll to avoid taking damage, modified for the circumstances listed on the Ejection Modifiers Table.



# SPECIAL CASE RULES

WOLFRNET ARCHIVE FILE: 32448-RDS-33/9/8

From the personal diaries of Jerome Blake, Myndo Waterly, Anastasius Focht, and Blane of Gibson. These entries show the evolution of ComStar as a political force, and may predict how both branches of this fractured order may respond in the future.

August 12, 2788. The Council Lords have left Terra without agreeing on who shall lead the Star League. It seems they could only agree on my appointment as Minister of Communications ... They will go to war, and soon. Somehow, I must guard the remnants of the civilization we so thoughtlessly threw away. I won't repair the communications network only to see it destroyed by those arrogant idiots. I refuse. But how to safeguard the technology? I might find allies ... among those like me who understand that our precious technology must not be destroyed. We must preserve the communications that all our worlds need to survive ... and when the Council Lords and their so-called Successor States have pounded themselves to dust, we will have the means to save humanity ...

... If we are to save humanity, then it is high time the Holy Order of ComStar took its rightful role in Inner Sphere politics. Those who quote the Blessed Blake to justify their dithering neutrality have prolonged human suffering over hundreds of years. Had the Order but dared to intervene in the Succession Wars ...! But my predecessors feared to reveal our proud Com Guards to the Successor States, feared to take action because they might make mistakes. Well, I do not fear action. I will show our Com Guards to the Inner Sphere's pathetic pseudo-rulers and let them know that ComStar is a military power to be reckoned with. Then let the chips fall where they may ...

... I wish I could have let Myndo Waterly live.

At least I did not shoot her in rage, though I had cause. That misguided fool, plotting treachery against the Inner Sphere while so many of our Com Guards died fighting the Clans on Tukayyid! She wanted to recreate the Star League in her own benighted image, as a ComStar theocracy...! Primus

*Continued on page 86*

## EJECTION MODIFIERS TABLE

Landing Terrain	Modifier
Clear	-2
Water	-1
Rough	0
Rubble	0
Light Woods	+2
Heavy Woods	+3
Per Level of Building	+1
Situation	Modifier
BattleMech Prone	+5
Pilot Unconscious	+3
Per Point of Head Internal Structure Damage	+1
Automatic Ejection	+1

A pilot who fails this Piloting Skill Roll takes 1 point of damage and may need to make a Consciousness Roll.

A conscious pilot who successfully ejects may move at the rate of 1 MP per turn in the same manner as a standard infantry unit. He may be fired on in the same manner as an infantry unit, but with an additional +2 to-hit modifier. If the pilot ends a Movement Phase in the same hex with any unit (friendly or enemy), the pilot is considered to have been picked up in the End Phase; he may choose by which unit if more than one occupies the hex. Pilots picked up by friendly units that survive the battle or move off the board have survived and can be used again in future games. Players may ransom pilots captured by enemy forces if they wish.

## FIRE

Many battles are decided not by the skill or abilities of the soldiers involved but by the spread of fire across the battlefield. Players may use the following rules to simulate the effects of fire.

Place a fire counter on any hex that is set on fire during the game. Use one produced by FASA or create your own. Once started, a fire will continue to burn for the rest of the game. For each turn that a building is on fire, it loses 2 CF. If a BattleMech moves through a burning building, it suffers normal heat build-up from fire as well as all other normal damage.

## ACCIDENTAL FIRES

Weapons powerful enough to smash a BattleMech with one blow may also create extensive collateral damage, the most devastating of which is fire. Players may use the following rules to represent accidental fires.

A unit attempting to clear a wooded hex (see **Clearing Woods**, p. 81) runs the risk of setting the woods on fire accidentally. To represent this risk, the player rolls 2D6. On a result of 5 or less, the woods have been accidentally set alight rather than cleared.

If a weapon attack against a unit occupying a wooded hex misses its target, and the weapon can be used to start fires (see **Intentional Fires**, below) or convert terrain (see **Clearing Woods**), the attacking player rolls 2D6 to determine whether his attack accidentally set a fire or changed the terrain in the target's hex. On a result of 2 or 3, the hex catches fire. If the result is an 11 or 12 and the hex was Light Woods, it is now a Rough hex; if it was heavy woods, it is now light woods. A building cannot be unintentionally set on fire.

# SPECIAL CASE RULES

## ◆ INTENTIONAL FIRES

BattleMechs carry many weapons capable of starting fires in wooded hexes. Once started, fires spread easily from hex to hex, producing heat build-up in BattleMechs moving through or standing in those hexes. Different weapons offer different chances of starting a fire.

Players who intend to start fires may declare that their unit will fire its weapons at any wooded or Building hex. Standard infantry weapons, with the exception of flamers, cannot be used to start a fire. Modify the base to-hit number by -4 for a stationary target for this attack, as well as for the attacker's normal movement and other appropriate modifiers. On a successful attack, the player rolls 2D6 and consults the Fire Table to determine if the attack started a fire. If the attack starts a fire, place a fire counter on the target hex. Multiple successful attempts to start a fire do not make the fire larger.

**FIRE TABLE**

### Starting Fires

Weapon Type	Success Number
Flamer	4+
Energy Weapon <sup>1</sup>	7+
Missile or Ballistic <sup>2</sup>	9+
Inferno	Automatic
Modifiers	
Woods	0
Light Building	0
Medium Building	+1
Heavy Building	+2
Hardened Building	+3
Other terrain	Fire cannot start or spread

### Spreading Fires

Hex is downwind	9+
Hex is 60° from downwind	11+
Crossing non-burning hex	+3

<sup>1</sup>May not use small laser or ER small laser.

<sup>2</sup>May not use Gauss rifle, SRM-2, and standard SRM infantry.

*A Marauder fires two PPCs at a Medium Building in an attempt to set it on fire. Both attacks hit. Energy weapons normally start fires on a die roll result of 7 or higher, but the player must modify this to-hit number by +1 because the target is a Medium Building, for a To-Hit Number of 8. The player rolls a 9 and a 10. Because the first attack succeeded, the second attack has no further effect, but the building is on fire.*

## ◆ EFFECTS OF FIRE

During the Heat Phase, a BattleMech occupying a burning hex absorbs an additional 5 Heat Points. A BattleMech also

absorbs 2 Heat Points for each burning hex that it moved out of during the Movement Phase. A unit occupying a hex ignited during the Attack Phase of the turn will not be affected by the fire until the Heat Phase of the following turn.

Unless the controlling player rolls an 8 or higher on 2D6, any non-BattleMech unit that ends its Movement Phase on the ground in a burning hex or moves along the ground through a burning hex is destroyed. The player must make this roll each time a unit meets either condition.

## SPREADING FIRES

Fires on the battlefield can spread from hex to hex in the direction of the wind through wooded and Building hexes, but cannot spread into Clear, Rough, or Water hexes.

### Determining Wind Direction

At the beginning of the game, declare one side of a hex on the mapsheet to be Direction 1, numbering the remaining hex-sides as 2 through 6, moving clockwise. Roll 1D6. The wind will blow in the direction indicated by the die roll result for the entire game.

### Determining Spread

During the End Phase of every turn, check to see if any fires currently on the map spread to additional hexes. Roll 2D6 for the adjacent hex directly downwind of a fire hex. If the result is equal to or greater than 9 and if that hex can burn (see the Fire Table), the fire spreads into the hex. Also roll 2D6 for each of the two hexes adjacent to the burning hex at 60 degrees from downwind (the remaining two hexes in the fire's "forward arc"). If the result is equal to or greater than 11 and if the hex can burn, the fire will spread into that hex as well.

A flammable hex directly downwind from a fire but separated from the fire by a non-burning hex may also catch on fire. Roll 2D6. On a result of 12, the fire spreads to a flammable hex directly downwind from a fire.

If one hex may catch fire because of its relationship to several burning hexes, roll for each possibility.

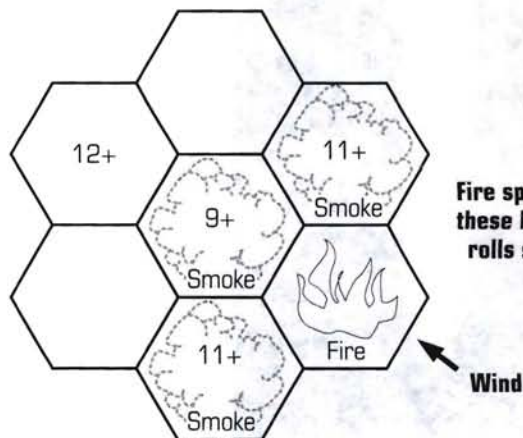

Fire spreads to these hexes on rolls shown.

## SPECIAL CASE RULES

*Continued from page 84*

Mori and I had no choice but to secularize the order—all the mysticism that built up over the centuries distorted Jerome Blake's original purpose. But we have lost so many to the religious-fanatic renegades, the Word of Blake ... The irony of that name makes me want to laugh. Or cry ...

... Evening on Gibson. Beautiful. This world, the gift of my friend Thomas Marik, is the first of many that the Word of Blake will use to accomplish its divine goal of returning the Inner Sphere to the ways of truth. I hope that Thomas will soon consent to be our Primus-in-exile, if only in memory of his own past days as one of our holy brethren ... So far, he has changed the subject every time I have spoken of it. I cannot blame him—who would wish to be Primus of an order as fractious and faction-ridden as we are? We must come to consensus on the Word of Blake's true purpose if we are ever to regain our former position of influence ...

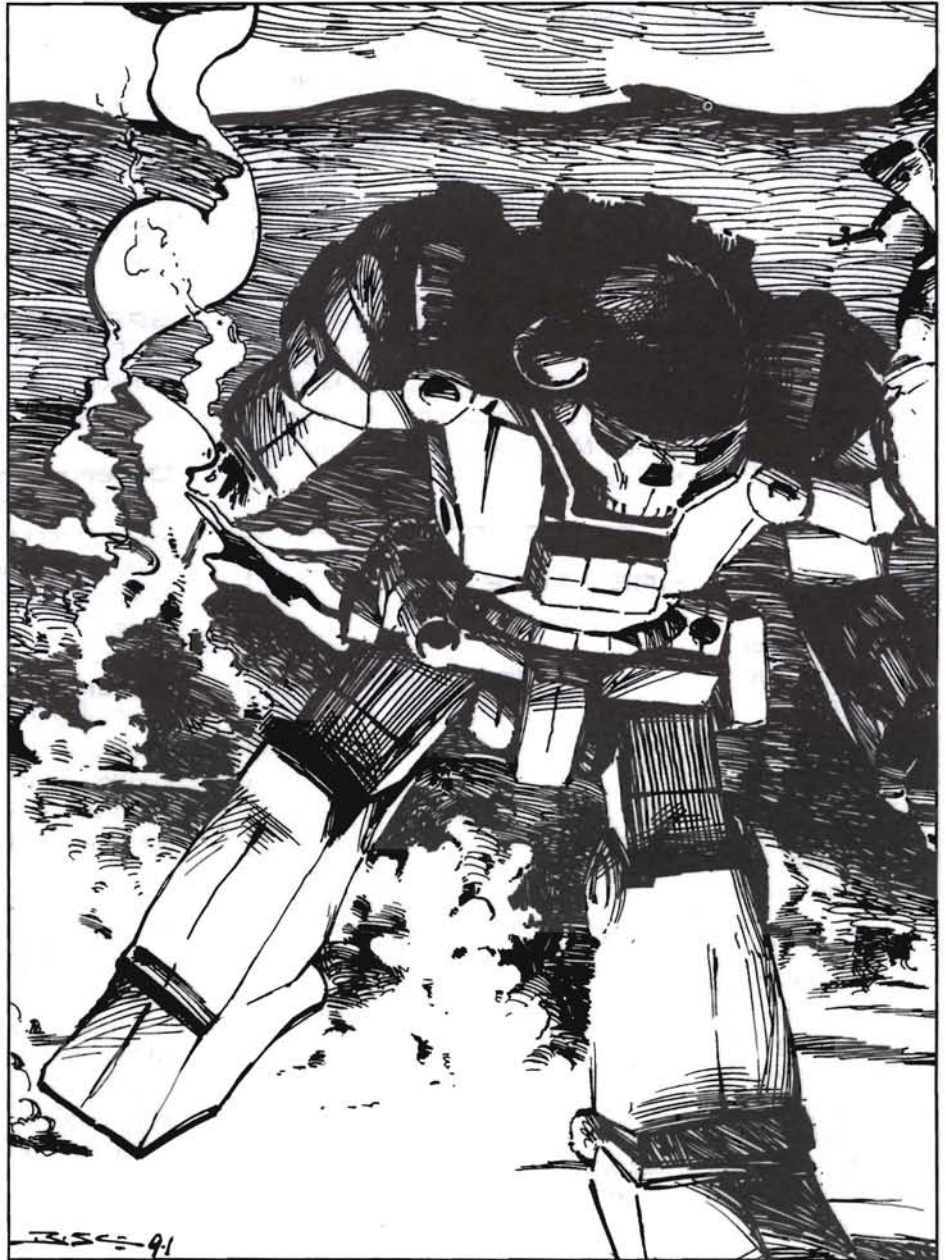
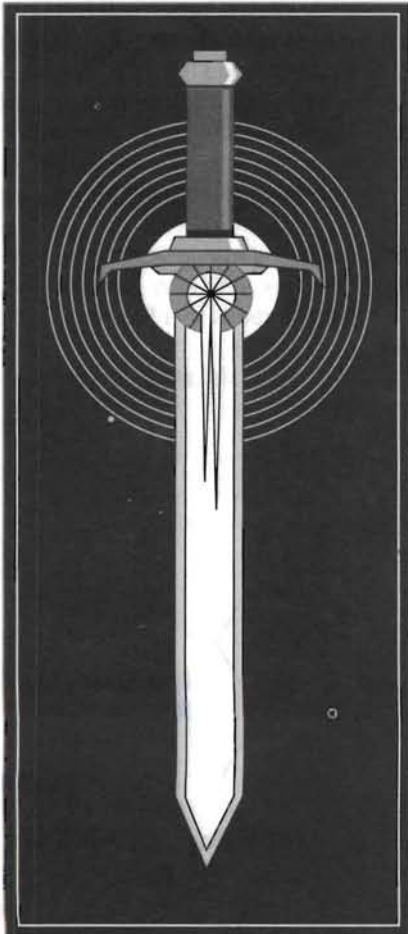

### ◆ SMOKE

A fire spreads smoke to the adjacent hex downwind and to the 2 adjacent hexes 60 degrees from downwind (i.e., the 3 adjacent hexes of the fire's "forward arc"). It does not create smoke in its own hex (though a fire upwind from it may do so). Treat a smoke-filled hex as though it were heavy woods for purposes of line of sight and to-hit modifiers, except that smoke only rises one level above the terrain it occupies. This means that under most circumstances, BattleMechs are unaffected by smoke.

### ◆ FLAK

Players can use onboard artillery and LB-X-class autocannons to make effective attacks against VTOLs. These rules do not affect strafing or dive-bombing aerospace or conventional aircraft.

# SPECIAL CASE RULES

## ARTILLERY FLAK

Units can use an onboard artillery weapon (Arrow IV with non-homing missiles, Long Tom, Sniper, or Thumper) to fire directly at an airborne VTOL. The player must declare that he is firing at the VTOL, and must have a valid line of sight to the target unit. Resolve the attack as normal for an artillery direct-fire attack, per the rules in **Onboard Artillery Fire**, p. 80, except do not modify the to-hit number for target movement. The Base To-Hit Number is 9, modified only by the firing unit's movement and current damage. Determine damage to flying units in the target and adjacent hexes as normal.

Direct artillery attacks against airborne units do not affect non-flying units in the target and adjacent hexes. VTOLs flying at a different altitude from the target VTOL are also unaffected. Shots that missed scatter as normal, but they explode at the elevation of the target unit.

## ◆ LB-X CLUSTER FLAK

LB-X autocannons firing cluster ammunition prove very effective against VTOLs in flight. For any attacks using cluster ammunition against a flying VTOL, subtract 3 from the base to-hit number rather than the usual -1 (for cluster munitions). Treat all other aspects of the attack as a normal weapon attack, except modify the to-hit number only by the firing unit's movement and current damage.

## FOUR-LEGGED BATTLEMECHS

The *Goliaths*, *Scorpions*, and other four-legged 'Mechs available in **BattleTech** use the same rules as bipedal BattleMechs. Players who wish to give quadrupedal BattleMechs (known as quads) a unique role in their games may use the following rules. Unless otherwise noted, use the rules for two-legged BattleMechs.

## ◆ CONSTRUCTION

Replace the right and left arm locations with an additional set of legs when constructing a quad 'Mech. These additional legs have the same number of internal structure boxes as standard legs, and so can mount additional armor. This second set of legs offers less room to mount weapons and other equipment than do arms—note that the quad Critical Hit Table has 12 fewer critical hit slots.

## MOVEMENT

Their unique configuration gives quad 'Mechs certain movement advantages over bipedal BattleMechs, mainly the ability to make lateral shifts and improved Piloting Skill targets.

### Lateral Shift

Quads may perform a special movement action that allows them to move laterally, or sideways, without changing their facings. A quad making a lateral shift moves into any adjacent hex that is not directly to its front or rear, while retaining its original facing.

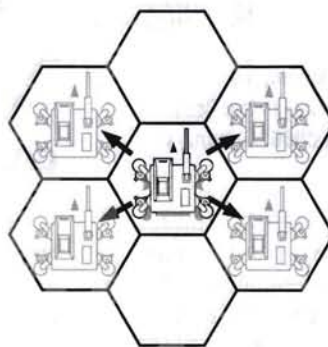

Possible Lateral Shifts  
(1 additional MP to enter hex)

A lateral shift costs 1 Movement Point in addition to the cost of moving into the target hex. Note that a two-legged BattleMech can perform the same action for 1 more MP.

## Piloting Skill Rolls

The inherent stability of four-legged BattleMechs allows them to move easily to avoid a fall. As long as none of the quad's legs are destroyed, add a -2 modifier to all Piloting Skill Rolls made to avoid falls. For example, a *Scorpion* piloted by a MechWarrior with a Piloting Skill of 5 would need only a 3 (5 - 2) or greater to remain standing when entering a Depth 2 Water hex. After a successful charge, this quad would remain standing on a roll of 5 (5 + 2 - 2) or greater.

As soon as one of the four legs is destroyed (blown off, or reduced to an Internal Structure of 0), the quad no longer receives this bonus.

## COMBAT

Use the following rules for four-legged BattleMech combat.

### Hit Location Table

Apply all damage that hits the right or left arm to the right or left forward leg of the four-legged BattleMech. Apply all damage hits to the right or left leg to the right or left rear leg.

### Leg Critical Hits

Consider all critical hit damage to be cumulative. Each hip critical hit reduces the quad's Walking MP by half. Thus, three destroyed hips cut the quad's Walking MP to an eighth of its normal rate, and the pilot must modify the Piloting Skill target by +4 (+6 for three destroyed hips, but -2 for intact legs).

A single destroyed leg immediately causes a quad to fall and negates the -2 Piloting Skill bonus. The quad is now subject to all Leg Destruction modifiers (see p. 44, **BattleMech Critical Hit Effects**).

### Physical Attacks

Because they have no arms, quads cannot make punching, pushing, or clubbing attacks. They may make charging attacks and, in the case of jump-capable quads, execute death from above attacks in the normal manner.

# SPECIAL CASE RULES

WOLFNET ARCHIVE FILE: 07050-TRO-28/12/5

Excerpt from the keynote speech by  
Precentor V Brian Carmichael to the Com  
Guard graduating class of 3056, Sandhurst  
Royal Military Academy

Never doubt that ComStar's Com Guards are the best fighting troops in the Inner Sphere. We field the best equipment. We maintain the tightest discipline. We adapt to the toughest situations. We are led by the greatest tactician in all the Houses and the Clans.

We didn't always look this good. At the beginning of Jerome Blake's efforts to preserve the technology of the Star League, we had the equipment, but no training to use it. As soon as Blake decided that ComStar might someday need a military arm to enforce its policies, he instituted a training program to create that tool. Primus Waterly gave us strength in numbers. Precentor Martial Focht gave us mobility, flexibility, and tactics on a strategic scale.

We showed what we were made of on Tukayyid by defeating a nearly invincible enemy. But the battle against the Clans drained our resources. It cost us hundreds of thousands of men, and almost as many machines. When we lost the warriors who disagreed with Primus Mori's vision of a more secular ComStar and took their equipment with them to the Free Worlds League—well, that hurt our resources even more.

Our strength has dropped nearly to the pre-Waterly level, as has the amount of territory we protect. Our remaining troops are distributed mainly between the seven worlds of the Free Rasalhague Republic, and their protection is our primary task. Where do we go from here? No one can say, and speculation is useless. But we must continue to train and prepare for whatever the Precentor Martial may ask us to do next.

## HEAT BUILD-UP

All four legs of a quadrupedal BattleMech can be submerged in Level 1 water. This allows all heat sinks in the legs to operate at double efficiency up to the maximum shown on the Heat Point Table, p. 53 in **Combat**.

## GUN EMPLACEMENTS

The following rules describe gun emplacements, which serve as simplified, stripped-down versions of static defenses. For larger versions of gun emplacements and more detailed rules for using such defensive tactics, see the **Static Defenses** section of the **BattleTech Tactical Handbook**.

A gun emplacement is a building designed to provide a weapons platform and protection for the crew manning those weapons. Treat a gun emplacement as a standard building with a CF. Any type of weapon can be housed in a gun emplacement. Within the limits of these rules, any number of weapon systems may be fixed in an emplacement or located in a turret providing a 360-degree traverse and the same firing arcs as vehicles. Turrets have Armor Points separate from the CF of the emplacement itself.

Players may mount a weapon to fire into one of 3 fixed firing arcs: north, east, or west, as illustrated below.

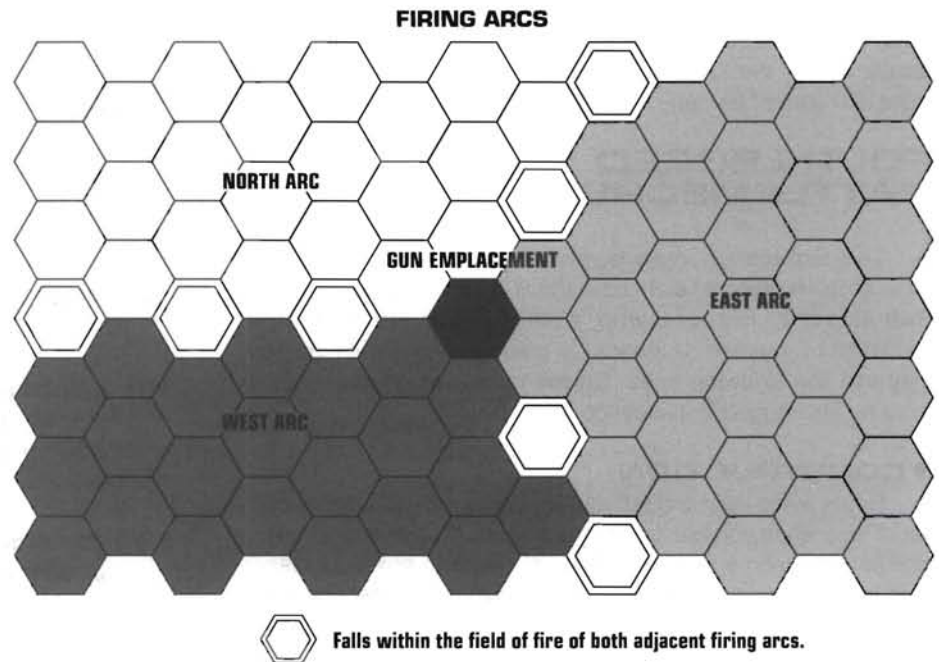

The north fixed firing arc always lies toward the north side of the mapsheet.

In combat, treat a gun emplacement as a building of the appropriate CF. For example, treat a gun emplacement with a CF 45 as a Heavy Building. When a gun emplacement takes a hit, roll 2D6 and consult the Gun Emplacement Damage Table to determine the hit location.

Attackers firing at a gun emplacement use all standard rules for firing at buildings, including the appropriate to-hit modifiers and fire damage.

If a turret takes damage that locks it into place but leaves the weapons intact, it can fire those weapons into its current arc. If the turret takes damage exceeding its Armor Points, the turret and its weapons are destroyed, but any remaining weapons in

## SPECIAL CASE RULES

### GUN EMPLACEMENT DAMAGE TABLE

Dice Roll (2D6)	Effect
2	Critical hit: All weapons destroyed
3	Turret hit and locked (or normal damage)
4-5	Turret hit (or normal damage)
6-8	Building takes normal damage
9-10	Turret hit (or normal damage)
11	Turret hit and locked (or normal damage)
12	Crew killed, weapons intact

the emplacement continue to function until the building itself is reduced to rubble. If the building has no turret and the die roll to determine hit location results in a 3-5 or 9-11, the building itself takes the damage.

### ◆ HIDDEN UNITS

At the start of a game, each side may secretly hide on the map a number of units determined by the scenario being played or agreed to by all players. Players should write down the number of each hex in which a unit is hidden, and designate the unit's facing.

BattleMechs cannot be hidden in Clear or Paved hexes.

Hidden units will remain hidden until they attack or move, or until an enemy unit moves into their hex, attempts to move into their hex, or ends its movement adjacent to their hex.

If a unit attempts to enter a hex containing a hidden unit, and if by doing so would violate the stacking rules (see **Stacking**, p. 24), the unit immediately ends its movement, and the hidden unit is revealed.

### ◆ POINT BLANK SHOTS FROM HIDDEN UNITS

When an enemy unit moves into or ends its movement adjacent to a hex occupied by a hidden unit, the hidden unit may immediately fire a pointblank shot, but only if the unit was placed on the map as part of the game set-up and has not yet moved or fired. The unit may only fire weapons with a valid firing arc to the target, using a Range of 1. However, the hidden unit may immediately torso twist or rotate its turret in order to bring its weapons to bear against the target. Do not modify the base to-hit number for movement or terrain. Hidden units cannot make physical attacks. Any damage takes effect immediately during the Movement Phase, and the results may affect the actions of the target unit for the rest of the phase. A unit attacking with a pointblank shot

may not move, fire again, or perform any other action during that turn.

### HOSTILE ENVIRONMENTS

Players may use the following rules to simulate combat in extreme temperatures, low gravity, difficult terrain, or even vacuum.

#### EXTREME TEMPERATURES

For combat in temperatures between  $-30$  and  $50$  degrees Celsius ( $-22^{\circ}$  and  $122^{\circ}$  Fahrenheit), the environmental conditions have no impact on a game of **BattleTech**. However, fighting in significantly higher or lower temperatures affects how well BattleMechs dissipate heat and degrades the combat effectiveness of other units.

For BattleMechs, for each  $10^{\circ}$  C (or fraction thereof) higher than  $50^{\circ}$  C, add 1 Heat Point to the unit's overall heat build-up each turn. For every  $10^{\circ}$  C (or fraction thereof) less than  $-30^{\circ}$  C, subtract 1 Heat Point in the BattleMech's overall heat build-up each turn.

For vehicles, for each  $10^{\circ}$  C (or fraction thereof) higher than  $50^{\circ}$  C, reduce their cruising speed by 1 Movement Point. For every  $10^{\circ}$  C (or fraction thereof) less than  $-30^{\circ}$  C, reduce their cruising speed by 1 Movement Point. Recalculate flank speed based on the new cruising speed. Extreme temperatures affect infantry in battle armor in the same way.

Unarmored infantry platoons cannot be deployed outside of a vehicle or building in temperatures that exceed  $50^{\circ}$  C or are less than  $-30^{\circ}$  C.

#### ICE

Extreme cold ( $0^{\circ}$  C or less) can cause a body of water to freeze. This may allow units to cross a Water hex more easily, though they run the risk that the ice will break and the units will fall through. In addition, normal terrain can become coated with ice, making all movement treacherous.

Prior to the start of the game, players should indicate which hexes are ice-coated.

BattleMechs and ground vehicles that turn and then move on an ice-coated hex may skid (see **Skidding**, p. 23 in **Movement**), even if they are moving at walking or cruising speed. Treat wooded and Rough hexes as buildings if the unit crashes into them while skidding. If the unit skids on ice in a wooded or Rough Hex, the unit suffers damage as for a fall of 1 level. Vehicles take this damage on their Front side.

Any BattleMech, ground vehicle, or airborne vehicle that is landing (or crashing) and enters an ice-covered Water hex may break through the ice and fall into the water below if the hex is not frozen solid. Roll 1D6. On a result of 6, the ice breaks and the unit falls into the water. BattleMechs take one-half normal

## SPECIAL CASE RULES

WOLFNET ARCHIVE FILE: 44783-WR2-32/4/1

**From a political pamphlet currently circulating in the Lyran region, Federated Commonwealth**

The Clans are the greatest enemy that true humankind has ever known. Within two years, these vat-grown abominations supposedly descended from General Kerensky have conquered an area of space nearly as large as the Free Worlds League, slaughtering millions of innocents in the process. The so-called Clan occupation zones are a blight on the Inner Sphere, a dagger pointing straight at its heart.

The Com Guards defeated the Clans on Tukayyid, but their noble sacrifice will be in vain if we abide by the Truce of Tukayyid. That document, signed by the coward Victor Davion to keep his precious Federated Suns worlds safe, has left a third of the Lyran Commonwealth vulnerable to Clan attack! Countless Commonwealth worlds lie above the truce line—the Clans may attack them with impunity. Indeed, Clan Jade Falcon (whose occupation zone lies on the Lyran border) has already attempted to take the planet Morges. Who knows where their talons will reach next?

And the Clans are tightening their iron grip on the helpless planets they have subjugated. Even now, reliable sources in hiding on captive worlds report massive migrations from Clan space into the occupation zones. For proof of these claims, simply look at the heavily armed Clan garrisons on these worlds. Though the Clan enemy tries to conceal his true intent by using second-line troops in second-line 'Mechs, these "inferior" machines are no less deadly than the front-line troops' vaunted OmniMechs. Why would they garrison subjugated planets so heavily, when their initial assault robbed those worlds of defenders? Because they know that word of the migration will get out—and when it does, the armies of the Inner Sphere will attack in force.

But we cannot wait for our craven leaders to attack. We must choose the moment. All patriotic sons and daughters of the Inner Sphere must launch the final war against our enemy. We must take back the Clan occupation zones—we owe it to our glorious dead, and to the living who still suffer under Clan tyranny!

falling damage (for falling in water). Ground or air vehicles are destroyed (but hovercraft are unaffected). The Water hex remains unfrozen for the remainder of the game.

This breakthrough rule should only be used if the players decide that the water in a hex is not frozen solid. Note that the tonnage of the unit is not a factor in a unit breaking through the ice—it is, rather, a factor of ground pressure, not overall weight. Larger BattleMechs and vehicles have larger "footprints," and so the weight of their presence on the ice exerts pressure per square meter as low as that of lighter units with smaller footprints.

A BattleMech can climb out of a Depth 1 or Depth 2 Water hex and move back onto the ice. A BattleMech in Depth 3+ water must travel under the ice, following the underlying terrain, until it reaches a Depth 2 hex, at which point it can break through the ice (see **Underwater Operations**, p. 95), or until it reaches a Depth 1 hex, at which time it automatically breaks through the ice, converting the hex to open water.

For jumping BattleMechs that land on an ice-covered Water hex, roll 1D6. On a result of 4+, they break the ice and fall through.

An ice-covered Water hex can be converted into a normal Water hex by melting the ice with weapons fire, using the **Clearing Woods** rules, p. 81. Units (except hovercraft) occupying a hex converted in this way fall into the water. Infantry units and ground vehicles which fall into the water are destroyed.

### ◆ HIGH/LOW GRAVITY

Gravity that is significantly greater or less than normal Earth gravity (1 G) affects a unit's movement. As shown in the following rules, while low gravity generally allows units to move faster, it does not reduce their mass and momentum, and so offers a chance of damage through normal movement. A BattleMech traveling 200 kph on a .5 G world is likely to snap off its legs.

Gravity affects all units' movement the same way. To determine a unit's movement rates as affected by gravity, divide its Walking (or Cruising) and Jumping MP by the G-rating of the world and round to the nearest whole number (round down at .5). Calculate the new Running (or Flank) MP based on the revised Walking (or Cruising) MP. Thus, a unit with a normal Walking MP of 4 would have Walking MP of 5 on a .75 G world ( $4 \div .75 = 5.3$ , rounded to 5). On a 1.25-G world, that same unit would have a Walking rate of 3 ( $4 \div 1.25 = 3.2$ , rounded to 3). A unit's movement cannot be more than doubled by the effects of gravity, and units whose MP is reduced to 0 by the effects of gravity are incapable of moving.

BattleMech legs and vehicle suspensions are designed to operate at maximum efficiency on worlds with close to 1 G gravity. If the gravity of a world allows the unit to move faster than normal, the strain to the unit's systems may damage its internal structure. If a unit spends more MP than its normal Running (or Flank) MP during a turn (as in the example above of the unit moving on a world with .75 G), the player must make a Piloting Skill Roll at the end of the Movement Phase, appropriately modified for relevant conditions, to determine if the unit takes any damage from moving at an unusual rate. If the Piloting Skill Roll fails, the unit takes the following damage: a BattleMech takes 1 point of internal structure damage to each of its legs for every point of movement by which the unit exceeded its normal Running MP (the BattleMech does not fall if this roll fails). Thus, a BattleMech with a normal Running MP of 8 that spends 10 MP running during a turn and then fails a Piloting Skill Roll would take 2 points of internal structure damage to each of its legs. A vehicle takes 1 point of damage to its Front side internal structure for each Movement Point spent that exceeds its normal Flank MP.

A BattleMech that jumps in any gravity other than 1 G takes damage under the same conditions. Make a Piloting Skill Roll, adding the appropriate modifiers. If the roll fails, the BattleMech takes 1 point of internal structure damage to each leg for each Movement Point spent jumping that exceeds its normal Jumping MP.

As usual, roll on the Determining Critical Hits Table to resolve whether internal structure damage resulted in a critical hit. Apply critical hit results before the Weapon Attack Phase of the turn.

## SPECIAL CASE RULES

If gravity allows a unit to exceed its movement MP during the Physical Attack Phase, make the required Piloting Skill Roll and apply the results, if any, at the end of that phase.

Calculate as usual the damage from falls taken in unusual gravity, then multiply the result by the G-rating of the world and apply the total damage to the unit.

### SWAMP

Depth 0 Water hexes normally represent swampy ground.

Though standard **Battle-Tech** rules treat this terrain essentially as a Clear hex, players can use the following rules to more realistically represent the effects of swampy terrain.

Before beginning play, designate all Depth 0 Water hexes as some other type of terrain, and choose any number of Clear, Rough, or wooded hexes to be swampy. The hex's original terrain type still restricts certain units. For example, wheeled vehicles cannot enter swampy Rough or wooded hexes. Use the swampy terrain's original terrain for determining LOS. Swampy terrain does, however, impede movement (increases the MP cost for the terrain), and might trap unlucky units.

Increase the movement cost to enter any swampy hex by 1 MP. Thus, entering a swampy Clear hex costs 2 MP (rather than 1 MP) and entering a swampy Light Woods hex costs 3 MP. This increased MP cost applies to all units, including infantry, but not hovercraft.

When a BattleMech or ground vehicle enters a swampy hex, the player must make a Piloting Skill Roll. If the roll fails, the unit becomes stuck in the hex and may not move for the rest of the turn (a BattleMech that fails this roll does not fall). The unit may torso twist or rotate its turret normally, but may not change its facing. For infantry entering a swampy hex, roll 2D6. On a result of 4 or less, the unit becomes stuck. For any weapon or physical attacks made against a unit stuck in a swampy hex, modify the to-hit number by -2.

A jumping BattleMech that lands in a swampy hex automatically becomes stuck, though jumping infantry units do not.

At the start of the next turn's Movement Phase, the player controlling a stuck unit makes a Piloting Skill Roll. On a successful roll, the unit breaks away from the swampy terrain and may move normally. If the roll fails, the unit remains stuck (but does not fall), and the player makes another Piloting Skill Roll at the start of the next Movement Phase.



### VACUUM

All BattleMechs are capable of operating in a vacuum, though combat on an airless world poses many dangers. Exposing the inner workings of a BattleMech to a vacuum will freeze actuators and make weapon components fail.

Only fusion-powered vehicles can function in a vacuum.

### Hull Integrity

Whenever a BattleMech or vehicle operating in a vacuum takes a hit, the controlling player rolls 2D6. On a result of 10 or greater, the unit's hull has been breached. The integrity of that location has been lost and all components in that location exposed to vacuum. If all of a location's armor is destroyed, that location is automatically breached.

Treat all of a BattleMech's components in a breached location as nonfunctional. None of that location's actuators, weapons, or other equipment works; if the breached location contains engine slots, the engine now functions as if

it took as many critical hits as there were engine critical slots in that location.

Equipment and components in the breached location take critical hits per the standard rules, even though the component is temporarily nonfunctional. Do not transfer combat damage inflicted on a breached location until that location's internal structure is destroyed.

To operate in a vacuum, 10 percent of a fusion-powered ground vehicle's tonnage must be devoted to sealing the vehicle and providing life support for the crew. Hovercraft, naval vessels, and VTOLs cannot operate in a vacuum. If any location on a vehicle is breached in a vacuum, it is destroyed.

# SPECIAL CASE RULES

WOLFNET ARCHIVE FILE: 64552-LWB-43/2/6

## Excerpted from the papers of Nicholas Kerensky

We must eradicate all vestiges of the tainted past so that we can forge ourselves into a people worthy of our destiny. We must kill the traditions that blinded and crippled us for so long, for the old ways are like shackles and chains that would hinder our true strength. We are a new people, reborn in the fire, and we must follow new ways.

Henceforth, our 800 warriors will be divided into 20 Clans. And they will no longer fight as lances, companies, battalions or regiments. Instead, they will enter battle in Points, Stars, Binaries, Clusters and Galaxies.

### Point

Each MechWarrior shall form a Point. In the absence of an OmniMech, two aerospace fighters or five battle-armored Elementals shall comprise a Point.

### Star

Five Points shall form a Star and follow the orders of a Star Commander.

### Nova

A Star of OmniMechs and a Star of Elementals shall together form a Nova. Each OmniMech will carry a Point of Elementals into battle.

### Binary/Trinary/Supernova

Two Stars shall form a Binary. Three shall form a Trinary. Star Captains shall lead these units.

Nova pairs shall fight as Supernova Binaries. Three Novas shall form a Supernova Trinary.

### Cluster

The Cluster shall contain three to five Binaries, Trinaries or Supernovas. A Star Colonel shall command each Cluster.

### Galaxy

Each Galaxy shall contain three to five Clusters, all under the command of a Galaxy Commander.

## Infantry

Infantry units equipped with space suits and modified battle armor units can function normally in a vacuum. However, double any damage taken by an infantry unit while operating in a vacuum to represent the loss of personnel due to suit breaches, damage that normally would not result in any casualties.

## IMPROVED POSITIONS

Given enough time, a defending unit can improve the natural defenses of the surrounding terrain. If both sides agree to use the improved positions rule, units that start on the mapsheet may begin the game in improved positions. Treat these field fortifications as a Light Building with a CF of 15. These positions do not affect line of sight or movement in any manner, and a unit cannot climb on top of an improved position to increase its elevation level. Apply standard terrain modifiers to any unit in an improved position. Units that begin the game in improved positions may also use the **Hidden Units** rule, p. 89.

## ◆ LRM INDIRECT FIRE

Units armed with LRM-type weapons may fire those missiles indirectly. Indirect fire allows a unit that does not have a direct line of sight to a target to attack that target, though some friendly unit must have a valid line of sight to the target. Resolve LRM indirect fire attacks in the turn they are launched (rather than allowing flight time as for artillery).

The base to-hit number is the Gunnery Skill of the firing unit. Use the following modifiers:

- Range modifier based on the range between the target and the firing unit,
- +1 for indirect fire,
- All standard modifiers for target movement,
- All standard modifiers for attacker movement, and a modifier for the spotter's movement,
- Terrain modifiers are based on line of sight from the spotting unit.

The spotting unit cannot make any attacks in the turn that it spots for another unit.

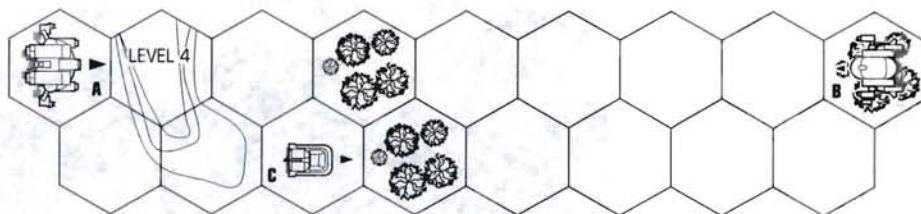

*An Archer has walked into Hex A, which lies behind a Level 4 hill. On the other side of the hill, in the Light Woods of Hex B, stands a Clan Dragonfly. Normally, the Archer could not attack this target because it does not have a valid line of sight to the Clan 'Mech. However, a friendly Savannah Master, which cruised this turn, is in Hex C with a valid line of sight through a hex of light woods to the Dragonfly. The Archer may fire its LRMs indirectly at the Dragonfly, using the Savannah Master as a spotter. The modified To-Hit Number is 4 (Gunnery Skill) + 2 (medium range) + 1 (indirect fire) + 1 (Archer movement) + 1 (Savannah Master movement) + 1 (through light woods) + 1 (into light woods), for a total of 11.*

# SPECIAL CASE RULES

## MINEFIELDS

The **BattleTech** rules offer the use of three forms of minefields: conventional fields, command-detonated fields, and vibrabomb fields.

Players assign minefields to hexes during the initial game set-up, secretly noting the type and location of each field. The number of minefields available to each player may be determined by the scenario or agreed by all players before beginning play. Though some scenarios may designate minefield locations, only the referee or controlling player should know those locations.

### CONVENTIONAL MINEFIELDS

At the start of play, the defending player receives a number of unspecified hexes that he can designate as conventional minefields. Whenever any ground unit (BattleMech, ground vehicle, or infantry, friend or foe) enters one or more of these designated hexes, the minefield automatically attacks the unit. The unit's player rolls 2D6. On a result of 7 or more, the unit has hit a mine. Resolve the attack and apply the damage before the unit continues its movement. The defending player may make this roll secretly, so that if the minefield does not explode, its location remains hidden.

Conventional minefields that explode inflict 6 points of damage to the Front of the unit entering the hex. To determine damage to BattleMechs entering a minefield, use the **BattleMech Kick Location Table**. A conventional minefield remains active and can make any number of attacks throughout the game, unless cleared (see **Clearing Minefields**, below).

### COMMAND-DETONATED MINEFIELDS

At the start of play, the defending player receives a number of unspecified hexes that he can mine with command-detonated explosives. At any time during the turn sequence that the defending player has line of sight to the mined hex, he may detonate any or all of these mines.

Detonating the explosives does 10 points of damage to each unit occupying the hex and 4 points of damage to each unit in each adjacent hex. Buildings will absorb damage until reduced to rubble, then the remainder of the damage affects units in the building. This applies to buildings in the target or an adjacent hex.

Apply damage from command-detonated mines to the Front side of the unit. To determine damage to BattleMechs entering a minefield, use the **BattleMech Kick Location Table**. Resolve the attack and apply the damage as soon as the explosion occurs.

A command-detonated hex may only be exploded once during a game.

### VIBRABOMB MINEFIELDS

At the start of play, the defending player receives a number of unspecified hexes that he can plant with vibrabombs. Treat a vibrabomb like a conventional mine, with the following excep-



tions. Vibrabombs can only be set off by the unique vibrations created by an approaching BattleMech. Vehicles and infantry cannot trigger vibrabombs. Any BattleMech can set off a vibrabomb, and vibrabombs go off automatically.

Vibrabombs have a variable sensitivity, and when placed must be set to respond to a specific mass. BattleMechs massing 10 or more tons lighter than the vibrabomb setting will not set off the minefield. A BattleMech massing more than 10 tons heavier than the setting will set off the mine at a distance of 1 hex for each 10 full tons by which it is heavier than the bomb's setting.

For example, if the bomb is set to respond to a 40-ton 'Mech, and a 75-ton *Marauder* enters a hex 3 hexes away, the bomb explodes. A 30-ton *Javelin* walking directly through the hex containing the bomb would not set it off.

A unit occupying the same hex as an exploding vibrabomb takes 10 points of damage to its Front side. Exploding vibrabombs do not affect adjacent hexes or the airspace above the target hex. Use the **BattleMech Kick Location Table** to determine damage to a BattleMech.

A vibrabomb only explodes once during a game.

### CLEARING MINEFIELDS

Clearing minefields is a dangerous job requiring great skill and finesse, and so it is usually assigned to infantry. If an enemy infantry unit ends its turn in a mined hex, the opposing player must be informed, even if the field has not been detonated.

Infantry that spends 1 Movement Phase in a mined hex without moving may elect to clear the field instead of attacking during the Weapon and Physical Attack Phases. If the infantry unit rolls 2D6 with a result of 10 or higher in the Weapon Attack Phase, they have successfully cleared the field. A die roll result of 5 or less means that the minefield exploded; the infantry takes normal damage. Conventional fields remain active after an accidental detonation, but accidental detonation clears vibrabomb and command-detonated minefields. If multiple infantry units are attempting to clear the same hex, all must make a successful roll to clear the minefield. If any unit rolls a 5 or less, all units attempting to clear the hex take damage.

WOLFNET ARCHIVE FILE: 09557-D55-32/4/7

From *Lectures on Strategy* by General  
Manfred Coughlin, Commonwealth Press,  
3053

Here's how most people see Clan Elementals:

"... They resembled men, but their mottled gray and black flesh and the abnormal thickness of the armored plates on their bodies marked them as alien. Their heads looked like lumps raised from the shoulders as an afterthought. A dark V-shaped viewport passed for a face. Thick cylinders reinforced the forearms; the right arm ended in the muzzle of a laser, the left in an underslung machine gun barrel. The left hand consisted of a thumb and two abnormally thick fingers, and the feet looked like huge, bifurcated hooves melded onto the legs of a smaller creature."<sup>1</sup>

As with many things about the Clans, reality is different.

The Clan Elemental is human, a genetically bred, perfect foot soldier. Larger, more muscular, and hardier than the average human, he also has another significant advantage that we are attempting to duplicate: a unique and powerful suit of battle armor.

Clan battle armor can take tremendous punishment from enemy weapons, and also performs automatic first aid on any Elemental that an enemy manages to hit. If the armor is breached, an as-yet-unknown substance inside the suit seals off the opening, covers the Elemental's wound, and administers drugs so powerful that they turn the injured Elemental into a battle-maddened fighting machine. The armor also enhances the Elemental's strength, allowing him to rip sheets of armor off a 'Mech with his hands.

Jet packs on the suits allow Elementals to jump significant distances, keeping the enemy off balance. Built-in weapons usually include a small laser in the right arm, a machine gun in the left, and a detachable short-range missile launcher on the back.

So far, only the Gray Death Legion has fielded significant battle-armored infantry. The Gray Death power suits cannot match the Clans', because Inner Sphere infantrymen lack the Elementals' size and strength.

<sup>1</sup>*Fight to the Death*, by Rommel Millar.

The player may also use off-board artillery fire or an LRM-20 salvo to clear a minefield. The player must designate the fire mission to clear the minefield. When the fire mission hits the hex, the player rolls 2D6. On a result of 5 or better, the strike clears the minefield. Artillery fire also does normal damage to units occupying the mined hex, though an LRM-20 salvo does not. Mines cleared in this way do no damage, and clearing artillery fire does not affect adjacent hexes in any way.

### ◆ NIGHT COMBAT

A lack of ambient light degrades the ability of BattleMechs and other combat units to target and hit an opposing unit. If combat takes place at night, modify all to-hit numbers by +2.

BattleMechs equipped with searchlights (such as the *Warhammer*, *Thor*, *Guillotine*, and *Rifleman*) may turn their searchlights on (or off) during the Movement Phase. A searchlight-equipped unit illuminates any one unit in its LOS and in its forward firing arc during any attack phase, as well as any units in intervening hexes between the illuminated unit and the searchlight-equipped unit. The unit also illuminates itself. Units attacking illuminated units disregard the +2 modifier for night fighting.

Each time a searchlight-equipped BattleMech takes a hit in any torso location (Front or Rear), or when a searchlight-equipped vehicle takes a hit in the Front or Side, the player must roll 2D6 to determine if the searchlight is destroyed. A result of 7+ means the searchlight is destroyed.

### REVERSING ARMS

BattleMechs constructed without hand and lower arm actuators in either arm may flip their arms over and fire their arm-mounted weapons directly into their rear firing arc.

A BattleMech that intends to reverse its arm-mounted weapons must flip both arms during the Reaction Phase. This maneuver takes the place of a torso twist. When it flips its arms, the BattleMech may then fire any arm-mounted weapon into the rear firing arc.

Note that BattleMechs constructed without lower arm and hand actuators suffer no weapons-fire penalties for lacking these components (see **Weapon Attacks**, p. 30).

### SCAVENGING AND REPAIR

To keep from throwing good BattleMechs after bad, the losing side often withdraws from the battlefield when it appears they no longer have a reasonable chance of winning. This allows the remaining side to claim any disabled and destroyed BattleMechs, enemy and friendly, remaining on the field. Naturally, some of these abandoned units consist of little more than scrap, with few, if any, parts intact enough to salvage. Others may need only minor repair, and some may be virtually intact, only disabled through overheating or injury to the MechWarrior. These BattleMechs may be the most valuable reward a BattleMech unit receives for its efforts. Players who learn to take maximum advantage of scavenging and repair opportunities greatly improve their units' chances for continued survival.

Each battle in an extended campaign is usually followed by a rest period in which MechWarriors have an opportunity to repair part or all of the damage their BattleMechs sustained in the fighting. The extent of the repairs possible immediately following a battle depends on the availability of repair materials in the unit's supply stores, the relative difficulty of the repair being attempted, and the time the unit is willing to devote to the repair.

## SPECIAL CASE RULES

### REPAIR DIFFICULTY TABLE (2D6)

Damage	Completely Repaired	Partially Repaired	Effect of Partial Repair	Time Required (in minutes)
Body Segment Destroyed	11+	—	—	240
Limb Blown Off	9+	—	—	180
Internal Structure Damage	6+	—	—	90
Critical Hit/Life Support	7+	—	—	120
Critical Hit/Sensors	8+	5-7	+1 to-hit	150
Critical Hit/Engine	7+	4-6	+3 heat/turn	300
Critical Hit/Gyros	9+	6-8	+2 to Piloting Skill	240
Damaged Weapons or Equipment				
1 Critical Hit	5+	—	—	100
2 Critical Hits	6+	—	—	150
3 Critical Hits	8+	—	—	200
4+ Critical Hits	10+	—	—	250
Critical Hit/Heat Sink	7+	4-6	1/2 effect	120
Other Critical Hits	5+	—	—	120
Armor Damaged	6+	3-5	1D6 armor lost perm.	30
Replace OmniMech Pod	3+	2	Double repair time	30

### MATERIAL AVAILABILITY

A BattleMech unit can only make repairs for which it has the necessary spare parts. Units acquire initial stockpiles of BattleMech replacement parts when creating their BattleMech units. (Detailed guidelines for creating military units appear in the **Mercenary's Handbook: 3055.**) Over time, units deplete these stores by making repairs, and may restock with booty from raids, parts gathered while scavenging defeated enemy BattleMechs, supplies received as wages or under a contract's payment terms, or through the rare cash purchase from House supplies.

The side that wins a battle is considered to have captured any enemy BattleMechs or other equipment that was destroyed or abandoned. These BattleMechs may be repaired or scrapped and used to repair other damaged BattleMechs. A location that has lost all of its internal structure is destroyed, along with all the equipment mounted there—none of it can be used for spare parts.

### REPAIR DIFFICULTY

To attempt to repair damage to a unit, a player makes a Repair Roll using 2D6, and compares the result to the Repair Difficulty Table. If the result equals or exceeds the number in the Completely Repaired column, the repair succeeds and the equipment in that location functions normally. If the result falls within the range of numbers in the Partially Repaired column, the equipment suffers the effect listed in the Effect of Partial Repair column. If a location cannot be partially repaired, no number appears in that column. Players attempting to repair a BattleMech may only make one Repair Roll per damaged area during the time required to make that repair. For example, a player attempting to repair damaged internal structure could only attempt the repair once (make a

Repair Roll) during the 90 minutes required for the repair. A Repair Roll that fails leaves the BattleMech in the same condition it was prior to the attempt. Thus, if a BattleMech with a critical hit to one engine fails its Repair Roll, the BattleMech could still operate, but would continue to generate 5 points of heat per turn and would only have 2 points of shielding left. Partially repaired heat sinks operate at half efficiency, as noted on the Repair Difficulty Table. Partial repair to heat sinks is cumulative (rounded down), so that 3 partially repaired single heat sinks reduce heat build-up by only 1 point per turn. Partially repaired damage cannot be fully repaired later.

To determine the total amount of time required to repair a BattleMech, simply add up the repair-time requirements for each repair needed. For example, if 3 BattleMech locations need armor restoration and the engine took 2 critical hits, the player would need to devote 690 minutes (11.5 hours) to attempt these five repairs. A repair takes the same amount of time whether or not it succeeds.

The Clans and the Inner Sphere use sufficiently different technologies that any attempt to use parts constructed by one to repair the other proves very difficult. Add +4 to the target number for all Repair Rolls when using incompatible parts.

### UNDERWATER OPERATIONS

The following rules describe movement, line of sight, weapon and physical attacks, and hull integrity for units moving underwater. Only BattleMechs and submarines can move underwater. BattleMechs in water of Depth 2 or deeper and submarines at Depth 1 or deeper are considered to be underwater and subject to these rules.

## SPECIAL CASE RULES

WOLFNET ARCHIVE FILE: 55341-PH9-32/7/6

From *Modern Warfare: A Manual of Tactics and Strategy*, by permission of the College of Military Arts, New Avalon Institute of Science

Most Great House militaries organize their forces along the Star League model described below. Irregular forces such as mercenary and Periphery units often use organizational schemes designed to maximize their limited resources, bolstering their main forces with vehicles and/or infantry.

### Lance

The lance is the smallest organizational unit, consisting of four BattleMechs or vehicles commanded by a lieutenant. The standard aerospace lance consists of two fighters and associated technical personnel.

### Company

The standard company consists of three lances (12 BattleMechs) commanded by a captain. A fourth lance of aerospace fighters may be assigned to the company to reinforce the primary BattleMech units. A company comprised solely of aerospace fighters is often referred to as a squadron.

### Battalion

A standard battalion consists of three companies (36 BattleMechs) commanded by a colonel or major. Battalions may include a command lance that provides mobile command and logistical support. Some battalions organize attached aerospace lances as separate companies or squadrons. A battalion that consists solely of aerospace squadrons is often referred to as a wing.

### Regiment

A standard regiment consists of three to five battalions (108 to 180 BattleMechs) commanded by a general or colonel. DropShips or JumpShips are usually attached to regiments, as are support battalions such as infantry or tank units.

### Regimental Combat Team (RCT)

Commanded by a general, the modern regimental combat team (RCT) consists of one regiment of BattleMechs, three regiments of armored vehicles, five infantry regiments, one artillery battalion and two aerospace fighter wings. RCTs were introduced to modern warfare during the Succession Wars by Federated Suns military leaders.

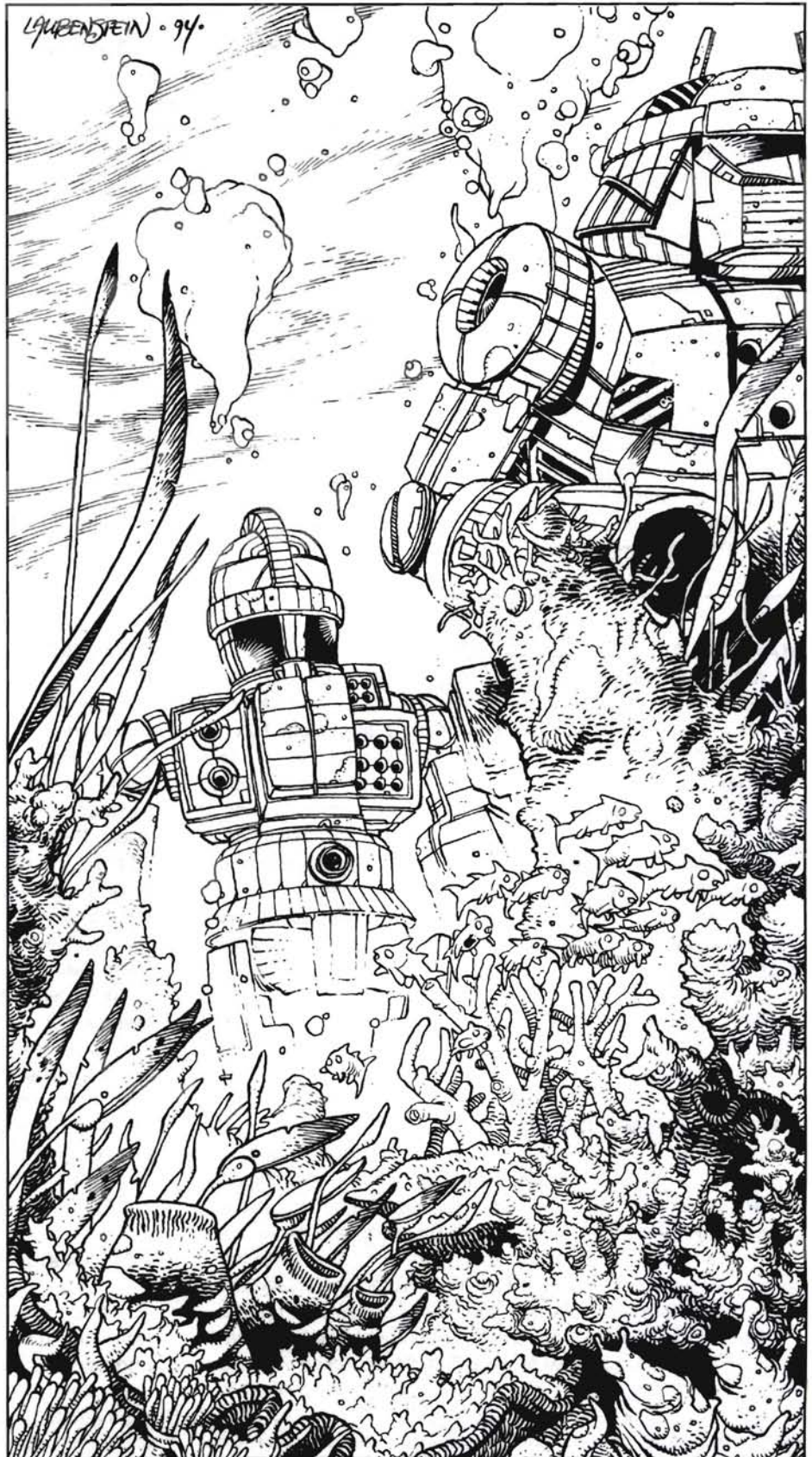

# SPECIAL CASE RULES

## UNDERWATER LINE OF SIGHT TABLE

Attacker is:	Target is:				BattleMech at Depth 1
	Underwater <sup>1</sup>	Surface Naval	Airborne	Ground <sup>2</sup>	
Underwater <sup>1</sup>	Yes	Yes	No	No	Yes <sup>4</sup>
Surface Naval	Yes	Yes	Yes	Yes	Yes <sup>3</sup>
Airborne	No	Yes	Yes	Yes	Yes <sup>3</sup>
Ground <sup>2</sup>	No	Yes	Yes	Yes	Yes <sup>3</sup>
BattleMech at Depth 1	Yes <sup>6</sup>	Yes <sup>5</sup>	Yes <sup>5</sup>	Yes <sup>5</sup>	Yes <sup>7</sup>

<sup>1</sup> Includes BattleMechs at Depth 2+.

<sup>2</sup> Includes BattleMechs at Level 0+.

<sup>3</sup> At +2 to hit (+3 for partial cover and -1 for being in water); use the BattleMech Punch Location Table.

<sup>4</sup> At +2 to hit (+3 for partial cover and -1 for being in water); use the BattleMech Kick Location Table.

<sup>5</sup> Can only fire torso, arm, or head weapons.

<sup>6</sup> Can only fire leg weapons.

<sup>7</sup> Can only fire leg weapons at legs and upper body weapons at upper bodies (+3 for partial cover and -1 for being in water).

## MOVEMENT

Submarines pay 1 MP for each hex they enter and 1 MP for each level of depth they change. An underwater BattleMech pays 4 MP for each hex it enters and must make a Piloting Skill Roll using the appropriate modifiers for each Water hex it enters of Depth 2 or deeper. In addition, a BattleMech must pay all standard MP for moving from one level (depth) to another (see **Movement Costs**, p. 18).

## LINE OF SIGHT

Calculate line of sight normally, treating level of depth as negative numbers. For example, a Depth of 1 is at Level -1 and so is 2 levels below a Level 1 hill. Units without line of sight cannot attack one another. The Underwater Line of Sight Table

summarizes which units can fire at each other and with what modifications.

## WEAPON ATTACKS

Units may only fire energy weapons and torpedoes underwater.

Torpedoes are short- and long-range missiles specially designed to function underwater, and they use the same stats as their land-based counterparts. Torpedoes may only be fired from and into a Water hex of Depth 1 or greater, and the attacker must trace LOS through Water hexes of Depth 1 or greater. Units equipped with torpedo racks may not use normal missile ammo, and torpedo ammunition will not fit missile racks.

Lasers and PPCs may be fired underwater at greatly reduced ranges, as shown in the Underwater Range Table.

## UNDERWATER RANGE TABLE

	Min.	Short	Medium	Long
Small Laser	0	1	2	NA
Medium Laser	0	1-2	3-4	5-6
Large Laser	0	1-3	4-6	7-9
PPC	3	1-4	5-7	8-10
ER Small Laser	0	1	2	3-4
ER Medium Laser	0	1-3	4-7	8-10
ER Large Laser (Clan)	0	1-5	6-10	11-16
ER Large Laser (IS)	0	1-3	4-9	10-12
ER PPC	0	1-4	5-10	11-16
Small Pulse Laser (Clan)	0	1	2	3-4
Small Pulse Laser (IS)	0	1	2	NA
Medium Pulse Laser (Clan)	0	1-3	4-5	6-8
Medium Pulse Laser (IS)	0	1-2	3	4
Large Pulse Laser (Clan)	0	1-4	5-10	11-14
Large Pulse Laser (IS)	0	1-2	3-5	6-7

## SPECIAL CASE RULES

WOLFNET ARCHIVE FILE: 22756-QW9-31/6/7

From Aerial Klemenski's speech at the first (and last) Seminar for Working Mercenary Units, Outreach, Winter 3056

'Scuse me, but what the <deleted> are you talking about?! "Financial support for families and the disabled"? Are you off your <deleted> rockers?

Maybe big-time merc units like the Dragoons and the Legion can do that, but what about the rest of us? My Kashmir Crusaders haven't a <deleted> hope in hell of making enough money to even buy a drink. Hell, I can't even buy enough parts to keep my only lance operational. You guys forgot what it's like to be the Houses' battering ram in every little skirmish. You can turn down jobs you <deleted> don't like; we have to take every little <deleted> disgusting contract that comes along.

I just came from a <deleted> "no-brainer" in Marik. "Easy gig," the League rep said. "Hit Sacrando Industries on Campertown, test their defenses, bring back a report." <Deleted> weasel "forgot" to tell us that Sacrando Industries was working on new communications devices for the F-C, and that <deleted> Field Marshal Nondi Steiner was there watching the new equipment tests. We found out my ol' 'Mechs can move a <deleted> lot faster than I thought.

Back in the League, my <deleted> "connection" had died in a freak accident. Seems the F-C doesn't take kindly to raids on its factories.

Let me tally it up for those of you paying "benefits"—one JumpShip ride, two DropShip rides, one an emergency at five times the going rate, bad damage to three 'Mechs, and food and lodging on the <deleted> backwater of Harsefeld while I give kids rides in my 'Mech to earn enough money to get the hell off-planet and come here so I can learn how not to get screwed.

And now I'm listening to you <deleted> jabbering about long-term investments and financial packages for MechWarriors and their families. I came to Outreach to learn how to survive out there, not have my intelligence insulted! So call me when you're ready to talk turkey, huh? I'll be drinking a <deleted> beer in a warehouse while I rebuild my *Enforcer's* left leg.

### ◆ PHYSICAL ATTACKS

Submarines and BattleMechs underwater may make physical attacks, but the cushioning effect of the water reduces the damage by half. Punching attacks have a Damage Value of 1 for every 20 tons that the attacker weighs; kicking attacks have a Damage Value of 1 for every 10 tons that the attacker weighs; charging and ramming attacks do 1 point of damage for every 20 tons the attacker weighs times the number of hexes charged; clubbing attacks do 1 point of damage for every 10 tons the attacker weighs. BattleMechs underwater may not make death from above attacks, but such attacks may be made against them. Death from above attacks executed in this fashion inflict 1 point of damage to the target for every 20 tons the attacker weighs times 3, and 1 point of damage to the attacker for every 20 tons of its weight.

Consult the Physical Attacks against VTOLs Table, p. 65 of **Vehicles**, for the physical attacks a BattleMech may make against submarines and surface naval vessels. Submarines may ram units that occupy their same depth.

### ◆ HULL INTEGRITY

Whenever an underwater unit takes a hit, the controlling player rolls 2D6. On a result of 10 or greater, the unit's hull has been breached. The integrity of that location has been lost, and it fills with water. Only make this roll for flooding at the moment an underwater unit takes damage, not for a damaged unit that later enters the water.

Treat a flooded location as destroyed. Submarines with a flooded location sink to the bottom of the hex and are considered destroyed. Do not transfer damage inflicted on a flooded location until that location's internal structure is destroyed. If all of a location's armor is destroyed, that location is automatically flooded.

## CONSTRUCTION

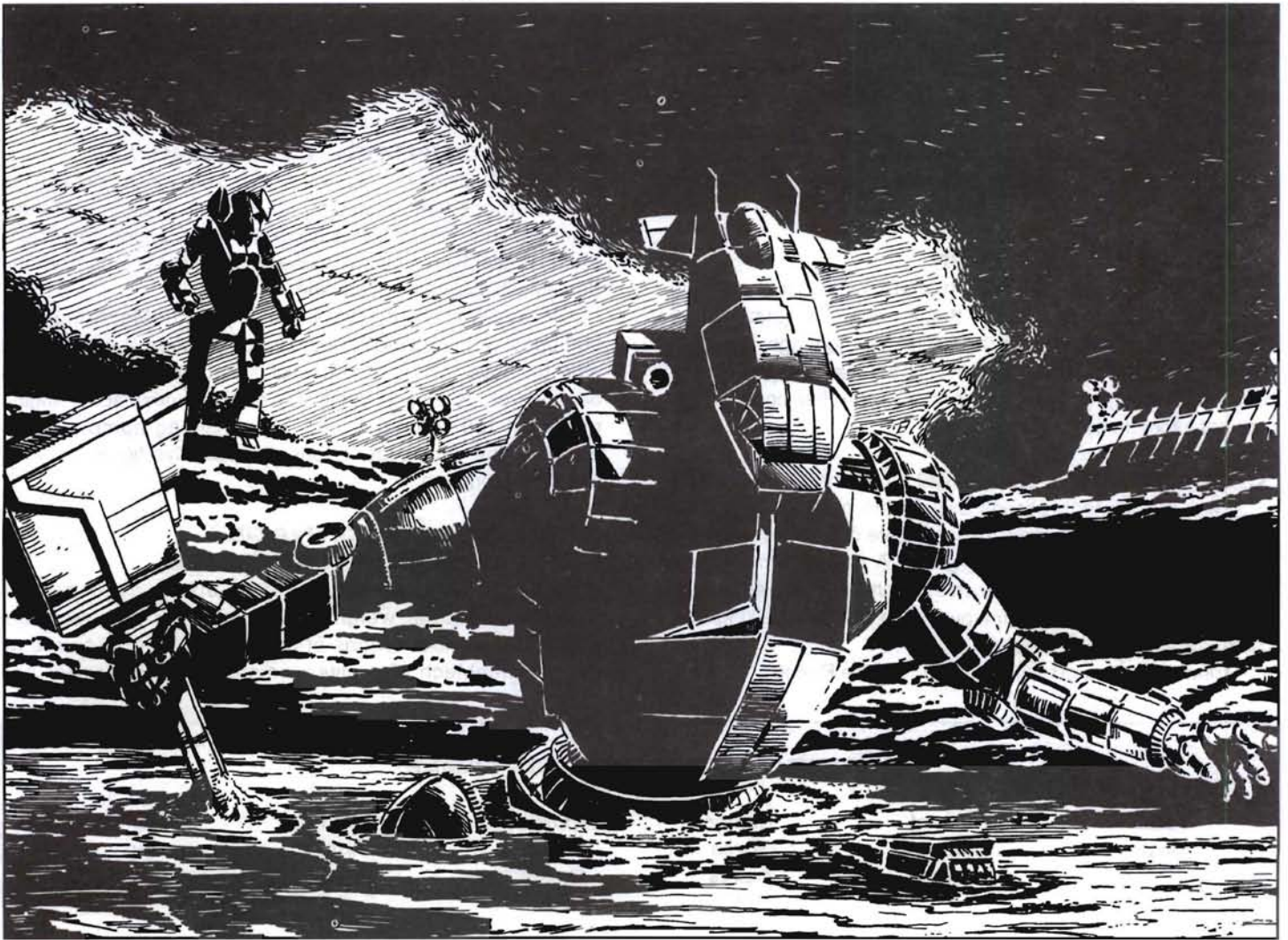

**BattleTech** players may want to design BattleMechs and vehicles to fit certain specifications or to serve specific purposes. This chapter provides rules for constructing such custom machines, including comprehensive Clan and Inner Sphere Weapons and Equipment Tables. Detailed descriptions of the weapons and equipment used in BattleMech and vehicle construction appear in the **Equipment** section, p. 112.

### BATTLEMECH CONSTRUCTION

The following system makes it possible for players to construct unique BattleMechs using any legal mix of speed, armor, and weapons they desire. These designs can then be pitted against other custom and standard machines on the battlefield.

In order to design a BattleMech, a player will need a piece of scratch paper, a pen, the appropriate Weapons and

Equipment Table, and a blank BattleMech Record Sheet. BattleMech design requires the player to perform the following steps in the order given. Each step is explained in detail below.

1. Determine Technology Base
2. Choose Tonnage
3. Determine Engine Rating
4. Add Control Components
5. Allocate Tonnage for Internal Structure
6. Determine Jump Capability
7. Add Extra Heat Sinks
8. Add Armor
9. Add Weapons, Ammunition, and Other Equipment
10. Complete Critical Hit Table
11. Allocate Armor Points
12. Complete the Record Sheet

# CONSTRUCTION

## 1. DETERMINE TECHNOLOGY BASE

BattleMechs can be constructed using one of two available technology bases, Inner Sphere or Clan. BattleMechs constructed using Clan technology tend to be lighter, more compact, and to generate less heat than their Inner Sphere counterparts. If a player uses Clan technology, he must also choose whether to design is an OmniMech or a standard BattleMech.

Based on the chosen technology, the player must be sure to use the appropriate Weapons and Equipment Table for his BattleMech.

## 2. CHOOSE TONNAGE

BattleMechs weigh between 10 and 100 tons (increasing in increments of 5 tons). Within these limits, the player may choose any tonnage. Record the BattleMech tonnage at the top of the sheet of scratch paper. The total weight of the BattleMech's engine, weapons, armor, and other components may not exceed this amount.

## 3. DETERMINE ENGINE RATING

Each BattleMech carries one fusion plant to power its movement and other systems. The relative output of this power plant is measured by its engine rating. A BattleMech's engine rating is determined by the 'Mech's weight and desired speed. Multiply the BattleMech's tonnage by the desired Walking MP. The result is the 'Mech's engine rating.

$$\text{Tonnage} \times \text{Desired Walking MP} = \text{Engine Rating}$$

The Fusion Engine Table, p. 103, lists the tonnage taken up by engines rated from 10 to 400. On the scratch paper, subtract the weight of the engine itself from the total tonnage of your BattleMech. The remaining tonnage provides room to add other components and systems. Note that a player may select an XL version of an engine if he wishes (see XL Engines, p. 122 in **Equipment**).

## 4. ADD CONTROL COMPONENTS

Every BattleMech must have a cockpit, which contains the MechWarrior's control station, life-support system, and electronic sensors. All BattleMech cockpits weigh 3 tons, regardless of the BattleMech's overall tonnage. Subtract 3 tons from the BattleMech's remaining tonnage.

In addition to its cockpit, every BattleMech must be equipped with a powerful gyroscope to keep it upright and able to move. The exact size of a BattleMech's gyroscope depends on its engine rating. Divide the BattleMech's engine rating by 100 (rounding up). The resulting number is the weight of the gyroscope in tons. Subtract this figure from the remaining tonnage.

## 5. ALLOCATE TONNAGE FOR INTERNAL STRUCTURE

The internal structure takes up 10 percent of a BattleMech's total weight. The Internal Structure Table shows the number of tons of internal structure required by every BattleMech of a given weight, and the number and

**INTERNAL STRUCTURE TABLE**

Total 'Mech Tonnage	Tons of Internal Structure	Center Torso Boxes	L/R Torso Boxes	Each Arm Boxes	Each Leg Boxes
10	1	4	3	1	2
15	1.5	5	4	2	3
20	2.0	6	5	3	4
25	2.5	8	6	4	6
30	3.0	10	7	5	7
35	3.5	11	8	6	8
40	4.0	12	10	6	10
45	4.5	14	11	7	11
50	5.0	16	12	8	12
55	5.5	18	13	9	13
60	6.0	20	14	10	14
65	6.5	21	15	10	15
70	7.0	22	15	11	15
75	7.5	23	16	12	16
80	8.0	25	17	13	17
85	8.5	27	18	14	18
90	9.0	29	19	15	19
95	9.5	30	20	16	20
100	10.0	31	21	17	21

# CONSTRUCTION

allocation of the BattleMech's internal structure boxes. The head's internal structure is not listed on the table, because all BattleMech heads takes up 3 internal structure boxes.

Mark out any excess boxes on the Internal Structure Diagram of the record sheet to indicate the number of boxes that make up each hit location.

Players may also choose to build their 'Mechs using endo steel technology. If the 'Mech will use endo steel in its construction, reduce the internal structure weight requirement by half. Note that players who choose endo steel technology for an Inner Sphere 'Mech must fill in 14 critical slots (with endo steel) on the BattleMech's Critical Hit Table. Players who add endo steel to a Clan BattleMech must fill in 7 critical slots on the BattleMech's Critical Hit Table. (See also **Endo Steel Internal Structure**, p. 116 in **Equipment**.)

## 6. DETERMINE JUMP CAPABILITY

BattleMechs may be equipped with jump jets in their legs and/or backs to allow jump movement. The weight of the jump jets depends on the weight of the BattleMech and the Jumping MP desired, as shown in the Jump Jet Weight Table. A BattleMech cannot be constructed with Jumping MP greater than its Walking MP.

Each jump jet gives the BattleMech one Jumping Movement Point, so that a BattleMech with 4 jump jets would have a Jumping MP of 4.

Subtract the total weight of the BattleMech's jump jets from the 'Mech's remaining tonnage.

### JUMP JET WEIGHT TABLE

'Mech Tonnage	Jump Jet Weight
10-55	.5 tons/Jump MP
60-85	1 ton/Jump MP
90-100	2 tons/Jump MP

## 7. ADD EXTRA HEAT SINKS

Heat sinks dissipate heat produced by movement, weapons fire, and other actions. Every BattleMech comes equipped with 10 heat sinks integral to the design that do not take up tonnage. However, most BattleMechs need more than 10 heat sinks to get rid of excess heat efficiently. Extra heat sinks can be acquired at the cost of 1 ton per heat sink.

Players may choose either double or standard heat sinks (see **Heat Sinks**, p. 117 in **Equipment**). A BattleMech may only carry one type of heat sink, either standard or double heat sinks, but not a mixture of both. If the player chooses to equip the 'Mech with double heat sinks, the 10 heat sinks built into the 'Mech's design are double sinks. If standard heat sinks are selected, the 10 heat sinks that come with the 'Mech are standard heat sinks.

## 8. ADD ARMOR

Armor helps protect the BattleMech's internal structure and critical components. Armor can be standard or ferro-fibrous. For each ton of standard armor selected, the BattleMech has 16 Armor Points. Ferro-fibrous armor gives the 'Mech even more Armor Points (see **Ferro-Fibrous Armor**, p. 116 in **Equipment**). Note that carrying ferro-fibrous armor requires the player to fill in the same number of critical slots on the BattleMech's Critical Hit Table as for endo steel internal structure.

Determine the total number of Armor Points the BattleMech will carry. These points will be assigned to the BattleMech's locations in Step 11. Armor must be added in 1/2- or 1-ton lots.

## 9. ADD WEAPONS, AMMUNITION, AND OTHER EQUIPMENT

Every weapon or piece of equipment placed on a BattleMech weighs a certain amount, as shown in the Tons column of the Weapons and Equipment Tables. Select the weapons and equipment that the new BattleMech will carry. Add at least one ton (1/2 ton for machine guns) of ammunition for each class of missile launcher or ballistic weapon (except one-shot weapons, which can have no additional ammo). This required extra ammunition provides a varying number of shots, depending on the launcher or weapon. Note that certain pieces of equipment must be assigned to specific locations on the BattleMech's Critical Hit Table.

Players creating OmniMechs do not mount weapons at this stage. Instead, they allocate a specific tonnage to weapons and equipment pods. At the start of each game, a player with an OmniMech then adds appropriate weapons and equipment up to this allocated tonnage and available critical slots.

## ◆ 10. COMPLETE CRITICAL HIT TABLE

Each record sheet provides a Critical Hit Table describing every part of the BattleMech's body. Certain sections of this table are already filled in, because certain components and equipment must be located in specific body segments. In this step, the player assigns the BattleMech's additional heat sinks, jump jets, and weapons to different parts of its body, and places them in a slot for that location on the Critical Hit Table.

Remember that certain items take up more than one critical slot on the table. These items should be specially noted on the tables, because a critical hit to any one of these slots destroys the entire component or piece of equipment, and further hits to other slots assigned to the same item have no further effect (see sample record sheet, following).

Fill in critical slots for endo steel, ferro-fibrous armor and XL engines, as noted in their descriptions above and in the **Equipment** section.

# CONSTRUCTION

Assign one critical slot on either a leg or torso location to each jump jet's exhaust port.

Only a portion of the BattleMech's heat sinks require critical slots. A number of heat sinks equal to the engine rating divided by 25 (round down) are assumed to be an integral part of the engine. These heat sinks are only destroyed if the engine is totally destroyed, and so cannot take critical hits. For example, if the player adds 5 heat sinks (for a total of 15) to a BattleMech carrying an engine rated at 210, 8 of these sinks (210 ÷ 25) are considered integral to the engine and do not have to be assigned to critical slots. The other 7 [10 (free) + 5 (extra) - 8 (unallocated)] must be assigned to critical hits.

The number of blank critical slots remaining on the table for a given location limits the number of weapons and other equipment that may be placed in that location. Many weapons take up more than one critical slot, as shown on the Weapons and Equipment Tables. For example, the center torso has only 2 slots left empty on its Critical Hit Table, but a PPC takes up 3 spaces. Therefore, the player cannot place a PPC in a BattleMech's center torso. To free up more slots, a player may choose to remove arm actuators from his design. Only hand and lower arm actuators may be removed in this fashion. BattleMechs lacking these actuators suffer penalties when making certain types of physical attacks, as explained in **Combat**, p. 45.

The critical slots for AC/20-type weapons, Arrow IV missile systems, and artillery weapons (Long Tom, Thumper, and Sniper) can be split between two adjacent locations. For all other weapons and equipment, all critical slots must be in a single location.

Each ton of ammunition occupies 1 critical slot, but that slot need not be in the same location as the weapon that uses the

ammo. Note that though machine gun ammo can be acquired in half-ton lots, a critical slot can accommodate a full ton of MG ammo.

## 11. ALLOCATE ARMOR POINTS

Divide the total Armor Points carried by the BattleMech among the 11 different locations shown on the Armor Diagram.

The player chooses the exact number of Armor Points used to protect a given area, but the number of Armor Points in a single location may not exceed twice the number of Internal Structure boxes in that location, regardless of whether the armor is standard or ferro-fibrous. For example, if a BattleMech has 10 Internal Structure boxes in its left arm, then the left arm can carry no more than 20 Armor Points. The only exception to this rule is that all BattleMechs may place up to 9 Armor Points on their heads.

Note that the center, left, and right torso locations mount both Front and Rear armor. The armor allocated to the Front of a torso location cannot be used to protect the Rear of that location, and vice versa. The total armor allocated to the Front and Rear of a torso location cannot be greater than twice the number of the location's Internal Structure boxes.

Use the Armor Diagram on the record sheet to indicate the number of Armor Points protecting each part of the BattleMech's body. Mark out any excess boxes in the same way as for the Internal Structure Diagram.

Use the Armor Diagram on the record sheet to indicate the number of Armor Points protecting each part of the BattleMech's body. Mark out any excess boxes in the same way as for the Internal Structure Diagram.

## 12. COMPLETE THE RECORD SHEET

Complete the record sheet by listing the BattleMech's Mech Data and Warrior Data.

# BATTLEMECH

## BATTLEMECH RECORD SHEET

### ARMOR DIAGRAM

#### Mech Data

Type: **MAL-IR MAULER**    Ammunition: **90**  
 Movement Points: **3**    Technology Base: **3**  
 Walking: **3**     Clan  
 Running: **2**     Inner Sphere  
 Jumping: **0**     Inner Sphere

---

#### Weapons Inventory

Type	Location	Heat	Carriage	Min	Shot	Max	Mag
ER/LAS	RA	12	2	-	7	14	19
ER/LAS	LA	12	2	-	7	14	19
LRM-15	LT	5	4	4	7	14	21
LRM-15	RT	5	4	4	7	14	21
AC/12	CT	1	2	4	9	16	24
AC/12	RT	1	2	4	9	16	24
AC/12	LT	1	2	4	9	16	24
AC/12	LT	1	2	4	9	16	24

**\*LRM DAMAGE 2 / MISSILE HIT**

Total Heat Sinks: **11 (22)**

Single     Double

Auto Eject  
 Operational     Disabled

#### Warrior Data

Name: **MENAPHERO BRAYSON**  
 Gunnery Skill: **4**    Piloting Skill: **5**  
 Hits Taken: 

1	2	3	4	5	6
---	---	---	---	---	---

  
 Consciousness #: 

3	5	7	10	11	Dead
---	---	---	----	----	------

#### Heat Scale

30	Shutdown
28	Ammo Explosion, avoid on 8+
26	Shutdown, avoid on 10+
24	-3 Movement Points
22	+4 Modifier to Fire
20	Ammo Explosion, avoid on 6+
18	Shutdown, avoid on 8+
16	-4 Movement Points
14	Ammo Explosion, avoid on 4+
12	Shutdown, avoid on 6+
10	+3 Modifier to Fire
8	-3 Movement Points
6	Shutdown, avoid on 4+
4	+2 Modifier to Fire
2	-2 Movement Points
0	+1 Modifier to Fire
-1	-1 Movement Points

### Critical Hit Table

Location	Slot	Equipment
Left Arm	1	Shoulder
	2	Upper Arm Actuator
	3	Lower Arm Actuator
	4	ER/LAS
	5	ER/LAS
	6	ER/LAS
Right Arm	1	Shoulder
	2	Upper Arm Actuator
	3	Lower Arm Actuator
	4	ER/LAS
	5	ER/LAS
	6	ER/LAS
Head	1	Life Support
	2	Sensors
	3	Cockpit
	4	ERCO-FIBROUS
	5	Sensors
	6	Life Support
Center Torso	1	Engine
	2	Engine
	3	Gyro
	4	Gyro
	5	Gyro
	6	Gyro
Left Torso	1	LRM-15
	2	LRM-15
	3	LRM-15
	4	LRM-15
	5	LRM-15
	6	LRM-15
Right Torso	1	LRM-15
	2	LRM-15
	3	LRM-15
	4	LRM-15
	5	LRM-15
	6	LRM-15
Left Leg	1	Hip
	2	Upper Leg Actuator
	3	Lower Leg Actuator
	4	Foot Actuator
	5	Foot Actuator
	6	Foot Actuator
Right Leg	1	Hip
	2	Upper Leg Actuator
	3	Lower Leg Actuator
	4	Foot Actuator
	5	Foot Actuator
	6	Foot Actuator

BATTLEMECH is a Registered Trademark of FASA Corporation. Copyright 1994. Permission to photocopy for personal use.

102

# CONSTRUCTION

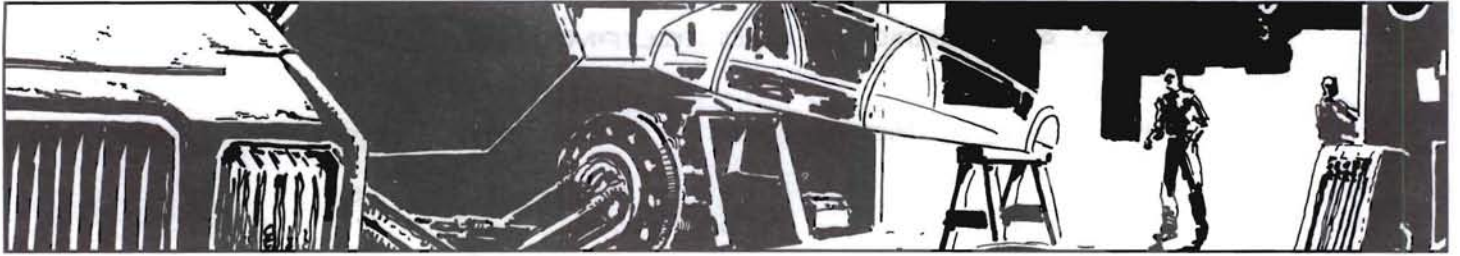

**FUSION ENGINE TABLE**

Engine Rating	Engine Manufacturer	Tonnage	Engine Rating	Engine Manufacturer	Tonnage
10	Omni	0.5	210	GM	9.0
15	GM	0.5	215	Core Tek	9.5
20	Pitban	0.5	220	DAV	10.0
25	Omni	0.5	225	VOX	10.0
30	Nissan	1.0	230	Leenex	10.5
35	VOX	1.0	235	GM	11.0
40	GM	1.0	240	Pitban	11.5
45	GM	1.0	245	Magna	12.0
50	DAV	1.5	250	Magna	12.5
55	VOX	1.5	255	Strand	13.0
60	Leenex	1.5	260	Magna	13.5
65	Nissan	2.0	265	Vlar	14.0
70	Omni	2.0	270	GM	14.5
75	GM	2.0	275	Core Tek	15.5
80	VOX	2.5	280	Vox	16.0
85	DAV	2.5	285	Pitban	16.5
90	DAV	3.0	290	Omni	17.5
95	Nissan	3.0	295	GM	18.0
100	Hermes	3.0	300	Vlar	19.0
105	DAV	3.5	305	GM	19.5
110	GM	3.5	310	Magna	20.5
115	GM	4.0	315	GM	21.5
120	GM	4.0	320	Pitban	22.5
125	Vlar	4.0	325	VOX	23.5
130	Magna	4.5	330	VOX	24.5
135	Hermes	4.5	335	Leenex	25.5
140	Leenex	5.0	340	VOX	27.0
145	Omni	5.0	345	Vlar	28.5
150	GM	5.5	350	Magna	29.5
155	GM	5.5	355	LTV	31.5
160	LTV	6.0	360	Hermes	33.0
165	VOX	6.0	365	Hermes	34.5
170	DAV	6.0	370	Magna	36.5
175	Omni	7.0	375	GM	38.5
180	GM	7.0	380	GM	41.0
185	GM	7.5	385	LTV	43.5
190	DAV	7.5	390	Magna	46.0
195	Nissan	8.0	395	Hermes	49.0
200	Nissan	8.5	400	LTV	52.5
205	Vlar	8.5			

# CONSTRUCTION

## CLAN WEAPONS AND EQUIPMENT TABLE

Type	Heat	Damage	Minimum	Short	Range		Tons	Crit.	Ammo
					Medium	Long			
<i>Energy Weapons</i>									
ER Laser (Large)	12	10	—	1-8	9-15	16-25	4	1	—
ER Laser (Medium)	5	7	—	1-5	6-10	11-15	1	1	—
ER Laser (Small)	2	5	—	1-2	3-4	5-6	.5	1	—
ER PPC	15	15	—	1-7	8-14	15-23	6	2	—
Flamer	3	2	—	1	2	3	.5	1	—
Pulse Laser (Large)	10	10	—	1-6	7-14	15-20	6	2	—
Pulse Laser (Medium)	4	7	—	1-4	5-8	9-12	2	1	—
Pulse Laser (Small)	2	3	—	1-2	3-4	5-6	1	1	—
<i>Ballistic Weapons</i>									
Anti-Missile System	1	*	—	—	—	—	.5	1	24
Flamer (Vehicle)	3	2	—	1	2	3	.5	1	20
Gauss Rifle	1	15	2	1-7	8-15	16-22	12	6	8
LB 2-X AC	1	2	4	1-10	11-20	21-30	5	3	45
LB 5-X AC	1	5	3	1-8	9-15	16-24	7	4	20
LB 10-X AC	2	10	—	1-6	7-12	13-18	10	5	10
LB 20-X AC	6	20	—	1-4	5-8	9-12	12	9	5
Machine Gun	0	2	—	1	2	3	.25	1	200
Ultra AC/2	1	2	2	1-9	10-18	19-27	5	2	45
Ultra AC/5	1	5	—	1-7	8-14	15-21	7	3	20
Ultra AC/10	3	10	—	1-6	7-12	13-18	10	4	10
Ultra AC/20	7	20	—	1-4	5-8	9-12	12	8	5
<i>Missile Weapons</i>									
LRM 5	2	1/missile	—	1-7	8-14	15-21	1	1	24
LRM 10	4	1/missile	—	1-7	8-14	15-21	2.5	1	12
LRM 15	5	1/missile	—	1-7	8-14	15-21	3.5	2	8
LRM 20	6	1/missile	—	1-7	8-14	15-21	5	4	6
Narc Missile Beacon	0	NA	—	1-4	5-8	9-12	2	1	6
SRM 2	2	2/missile	—	1-3	4-6	7-9	.5	1	50
SRM 4	3	2/missile	—	1-3	4-6	7-9	1	1	25
SRM 6	4	2/missile	—	1-3	4-6	7-9	1.5	1	15
Streak SRM-2	2	*	—	1-4	5-8	9-12	1	1	50
Streak SRM-4	3	*	—	1-4	5-8	9-12	2	1	25
Streak SRM-6	4	*	—	1-4	5-8	9-12	3	2	15
<i>Artillery Weapons*</i>									
Arrow IV System	10	20/10*	—	—	—	6 Maps	12	12	5
Long Tom	20	20/10*	—	—	—	20 Maps	30	30	5
Sniper	10	10/5*	—	—	—	12 Maps	20	20	10
Thumper	6	5/2*	—	—	—	14 Maps	15	15	20
<i>Other Equipment*</i>									
Active Probe	—	—	—	—	—	5	1	1	—
Anti-Personnel Pod	0	*	—	—	—	—	.5	1	—
Artemis IV FCS	—	—	—	—	—	—	1	1	—
CASE	—	—	—	—	—	—	0	0	—
Double Heat Sink	-2	—	—	—	—	—	1	2	—
ECM Suite	—	—	—	—	—	6	1	1	—

# CONSTRUCTION

## CLAN WEAPONS AND EQUIPMENT TABLE

Type	Heat	Damage	Minimum	Short	Range		Tons	Crit.	Ammo
					Medium	Long			
<i>Other Equipment *</i>									
Heat Sink	-1	—	—	—	—	—	1	1	—
MASC	—	—	—	—	—	—	**	**	—
TAG	0	—	—	1-5	6-9	10-15	1	1	—
Targeting Computer	—	—	—	—	—	—	*	*	—

\*See special rules for this equipment.

\*\*Mech Tonnage ÷ 25

## INNER SPHERE WEAPONS AND EQUIPMENT TABLE

Type	Heat	Damage	Minimum	Short	Range		Tons	Crit.	Ammo
					Medium	Long			
<i>Energy Weapons</i>									
ER Large Laser	12	8	—	1-7	8-14	15-19	5	2	—
ER PPC	15	10	—	1-7	8-14	15-23	7	3	—
Flamer	3	2	—	1	2	3	1	1	—
Large Laser	8	8	—	1-5	6-10	11-15	5	2	—
Medium Laser	3	5	—	1-3	4-6	7-9	1	1	—
Small Laser	1	3	—	1	2	3	.5	1	—
PPC	10	10	3	1-6	7-12	13-18	7	3	—
Pulse Laser (Large)	10	9	—	1-3	4-7	8-10	7	2	—
Pulse Laser (Medium)	4	6	—	1-2	3-4	5-6	2	1	—
Pulse Laser (Small)	2	3	—	1	2	3	1	1	—

### *Ballistic Weapons*

Anti-Missile System	1	*	—	—	—	—	.5	1	12
Autocannon/2	1	2	4	1-8	9-16	17-24	6	1	45
Autocannon/5	1	5	3	1-6	7-12	13-18	8	4	20
Autocannon/10	3	10	—	1-5	6-10	11-15	12	7	10
Autocannon/20	7	20	—	1-3	4-6	7-9	14	10	5
Flamer (Vehicle)	3	2	—	1	2	3	.5	1	20
Gauss Rifle	1	15	2	1-7	8-15	16-22	15	7	8
LB 10-X AC	2	10	—	1-6	7-12	13-18	11	6	10
Machine Gun	0	2	—	1	2	3	.5	1	200
Ultra AC/5	1	5	2	1-6	7-13	14-20	9	5	20

### *Missile Weapons*

LRM 5	2	1/missile	6	1-7	8-14	15-21	2	1	24
LRM 10	4	1/missile	6	1-7	8-14	15-21	5	2	12
LRM 15	5	1/missile	6	1-7	8-14	15-21	7	3	8
LRM 20	6	1/missile	6	1-7	8-14	15-21	10	5	6
Narc Missile Beacon	0	—	—	1-3	4-6	7-9	3	2	6
SRM 2	2	2/missile	—	1-3	4-6	7-9	1	1	50
SRM 4	3	2/missile	—	1-3	4-6	7-9	2	1	25
SRM 6	4	2/missile	—	1-3	4-6	7-9	3	2	15
Streak SRM-2	2	*	—	1-3	4-6	7-9	1.5	1	50

### *Artillery Weapons\**

Arrow IV System	10	20/10*	—	—	—	Maximum 5 Maps	15	15	5
Long Tom	20	20/10*	—	—	—	20 Maps	30	30	5

# CONSTRUCTION

## INNER SPHERE WEAPONS AND EQUIPMENT TABLE

Type	Heat	Damage	Minimum	Short	Range		Tons	Crit.	Ammo
					Medium	Long			
<i>Artillery Weapons*</i>									
Sniper	10	10/5*	—	—	—	12 Maps	20	20	10
Thumper	6	5/2*	—	—	—	14 Maps	15	15	20
<i>Other Equipment*</i>									
Artemis IV FCS	—	—	—	—	—	—	1	1	—
Beagle Active Probe	—	—	—	—	—	4	1.5	2	—
CASE	—	—	—	—	—	—	.5	1	—
C <sup>3</sup> Computer	—	—	—	—	—	—	5	5	—
C <sup>3</sup> Slave	—	—	—	—	—	—	1	1	—
Double Heat Sink	-2	—	—	—	—	—	1	3	—
Guardian ECM Suite	—	—	—	—	—	6	1.5	2	—
Hatchet	0	*	—	—	—	—	***	***	—
Heat Sink	-1	—	—	—	—	—	1	1	—
MASC	—	—	—	—	—	—	**	**	—
TAG	0	—	—	1-5	6-9	10-15	1	1	—
Triple-Strength Myomer	*	—	—	—	—	—	0	6	—

\*See special rules for this equipment.

\*\*Mech Tonnage ÷20

\*\*\*Mech Tonnage ÷15

## OUTFITTING AN OMNIMECH

Rather than using a standard OmniMech design, players may customize their OmniMechs to best suit the conditions of each battle by adding special equipment and weapons. Each OmniMech design indicates the machine's permanent features and specifies a number of tons available for additional gear. Certain types of equipment can be installed on any OmniMech, subject to weight and space limitations.

### WEAPONS

Players can always install weapons, provided that sufficient slots and tonnage remain available. All Clan weapons may be fitted to an OmniMech. When mounting weapons, be sure to allow space and include ammunition for those that require it. Weapon pods for OmniMechs automatically include the CASE ammo-protection feature (see **CASE**, p. 115 in **Equipment**) at no cost in space or weight.

All OmniMechs may also carry the following optional features.

### HEAT SINKS

Players may add additional heat sinks to an OmniMech if slots are available. Be sure to install compatible heat sinks; some OmniMech designs use standard heat sinks, but most use double heat sinks. If a player chooses to create an OmniMech that will carry weapons that produce a great deal

of heat, he may add the heat sinks with the weapons themselves so that the sinks can be removed with the weapons. This choice gives the player greater design flexibility. For example, the player may decide to reconfigure the OmniMech for a mission best accomplished by using ballistic weapons, which produce less heat when fired than lasers, or that will take place in a cool atmosphere. Fewer heat sinks will be necessary, and the space can be better used for other equipment. Heat sinks may be mounted in pods attached to any portion of the OmniMech, provided sufficient critical slots are available in the chosen location.

### JUMP JETS

Players may add jump jets to any OmniMech, whether or not its standard configuration has jump jets. Jump jets may only be mounted in pods on the left and right legs, the left and right torsos, and the center torso, and these locations must have sufficient critical slots available. Use the Determine Jump Capability rules, p. 101, for determining the necessary tonnage of jets to give the OmniMech the desired jump capacity.

### ELECTRONICS

Probes, targeting gear, and other high-tech electronics may be mounted in OmniMech pods or individually elsewhere on the 'Mech, provided there are sufficient slots available in the chosen hit location to fit the gear.

## OTHER EQUIPMENT

OmniMech pods can accommodate any of the equipment described in **Equipment**, p. 112, including anti-missile systems, A-pods, and so on. However, engines, endo steel, MASC, and armor cannot be added to an OmniMech using pod technology, for obvious reasons.

## USING ADD-ON PODS

When preparing an OmniMech for battle, use the descriptions of the standard OmniMech designs of the appropriate weight to determine the available tonnage for add-on pods. The equipment in the add-on pods cannot exceed this tonnage.

Designate a location for each pod to be attached to the OmniMech. The locations selected must have sufficient critical slots available for the systems being added.

Lower arm and hand actuators are themselves mounted as pods on OmniMechs, and so may be attached and detached freely between battles. They cannot be mounted on an arm that will carry any type of PPC, autocannon, or Gauss rifle. The player may choose whether to use actuators in conjunction with other arm-mounted weapons. If the player decides not to mount actuators, the appropriate arm actuator and hand actuator slots of the Arm Critical Hits Table are considered empty and may be used as extra critical slots for arm-mounted weapons. If an OmniMech's hand lacks a hand actuator, it cannot use that hand for any purpose (lifting, carrying, using clubs, and so on). OmniMechs without hand and/or arm actuators make less effective punching attacks.

The location and contents of all add-on pods must be designated before the battle begins.

## VEHICLE CONSTRUCTION

The following system makes it possible for players to construct unique vehicles and pit these designs against other custom and standard machines on the battlefield.

In order to design a vehicle, a player will need a piece of scratch paper, a pen, the appropriate Weapons and Equipment Table, and a blank Vehicle Record Sheet. Vehicle design requires the player to perform the following steps in the order given. Each step is explained in detail below.

1. Determine Technology Base
2. Choose Tonnage
3. Determine Engine Rating
4. Add Cockpit and Control Components
5. Add Lift Equipment/Rotors/Diving Equipment
6. Allocate Tonnage for Internal Structure
7. Add Armor
8. Add Weapons, Ammunition, and Other Equipment
9. Allocate Armor Points
10. Complete the Record Sheet

### 1. DETERMINE TECHNOLOGY BASE

Vehicles may be constructed using one of two available technology bases, Inner Sphere or Clan. Though they did not use them in the invasion of the Inner Sphere, the Clans can and

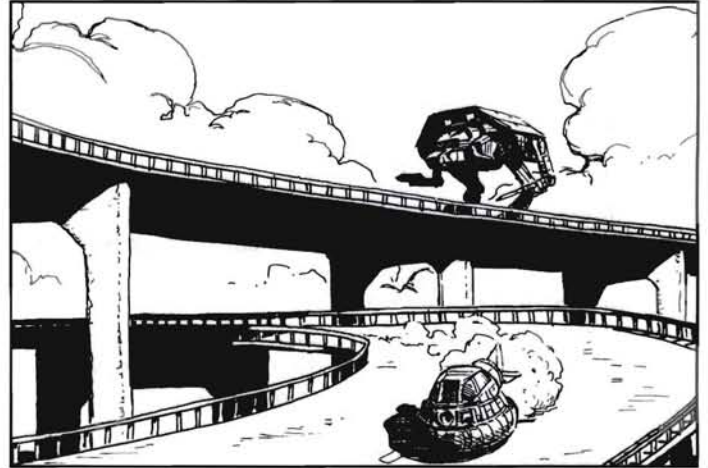

do construct combat vehicles. Vehicles constructed using Clan technology tend to be lighter and more compact than their Inner Sphere counterparts.

Based on the chosen technology, the player must be sure to use the appropriate Weapons and Equipment Table for his vehicle.

### 2. CHOOSE TONNAGE

Vehicle weight is limited by type, as shown in the Vehicle Table. Players may choose any tonnage within these limits. Record your vehicle's tonnage at the top of the sheet of scratch paper. The total weight of the vehicle's engine, weapons, armor, and other components may not exceed this amount.

### 3. DETERMINE ENGINE RATING

Each vehicle carries one power plant to power its movement and other systems. A vehicle's engine rating is determined by its weight, desired speed, and suspension or lift factor. Multiply the vehicle's tonnage by its desired Cruising MP, then subtract the suspension/lift factor (see Suspension Factor or Lift Factor in the Vehicle Table) from this total. The result is the vehicle's engine rating.

$(\text{Tonnage} \times \text{Desired Cruising MP}) - \text{Suspension/Lift Factor} = \text{Engine Rating}$

For example, a player creates a 25-ton hovercraft with a Cruising MP of 10 ( $25 \times 10 = 250$ ). The suspension factor for a 25-ton hovercraft is 130. This hovercraft needs an engine with a rating of 110 ( $250 - 130 = 120$ ). A player may select an XL version of the engine if he wishes (see XL Engines, p. 122 in **Equipment**).

Players may choose whether their vehicle will use a fusion or internal combustion engine. An internal combustion engine (ICE) weighs twice as much as an identically rated fusion engine, but ICE engines are cheaper and more readily available. Also, vehicles with fusion engines must add extra shielding and transmission equipment, the weight of which equals one half the weight of the fusion plant itself. Internal combustion engines are not available in the XL variant. (See Fusion Engine Table, p. 103.)

# CONSTRUCTION

## VEHICLE TABLE

### Ground Vehicles

#### Tracked

Maximum Tonnage	100
Suspension Factor	0
Terrain Restrictions	No Heavy Woods or Water

#### Wheeled

Maximum Tonnage	80
Suspension Factor	20
Terrain Restrictions	No Rough, Rubble, Woods, or Water

#### Hovercraft

Maximum Tonnage	50
Suspension Factor:	
<b>Vehicle Tons</b>	<b>Suspension Factor</b>
01-10	40
11-20	85
21-30	130
31-40	175
41-50	235
Terrain Restrictions	No Woods
Lift Equipment	10 % of hovercraft tonnage
Minimum Engine Weight	20 % of hovercraft tonnage

### Naval Vehicles

#### Hydrofoils

Maximum Tonnage	100
Suspension Factor:	
<b>Vehicle Tons</b>	<b>Suspension Factor</b>
01-10	60
11-20	105
21-30	150
31-40	195
41-50	255
51-60	300
61-70	345
71-80	390
81-90	435
91-100	480
Terrain Restrictions	Water hexes of Depth 1+ only
Lift Equipment	10 % of hydrofoil tonnage

### Naval Vehicles

#### Displacement Hulls and Submarines

Maximum Tonnage	300
Suspension Factor	30
Terrain Restrictions	Water hexes of Depth 1+ only
Submarine Diving Equipment	10 % of submarine tonnage

### VTOLs

Maximum Tonnage	30
Lift Factor:	
<b>Vehicle Tons</b>	<b>Lift Factor</b>
01-10	50
11-20	95
21-30	140
Lift Equipment	10 % of VTOL tonnage



## 4. ADD COCKPIT AND CONTROL COMPONENTS

Every vehicle must have a cockpit, which combines the equipment necessary to control the craft in combat. These control components take up 5 percent of the vehicle's total tonnage (rounded up to the nearest half ton).

## 5. ADD LIFT EQUIPMENT/ ROTORS/DIVING EQUIPMENT

Hovercraft, hydrofoils, VTOLs, and submarines all use special equipment to achieve their unique movement. This equipment weighs 10 percent of the vehicle's total tonnage (rounded up to the nearest half ton).

## 6. ALLOCATE TONNAGE FOR INTERNAL STRUCTURE

A vehicle's internal structure takes up 10 percent of its total weight (rounded up to the nearest half ton). Each of the vehicle's 5 damage locations (4 if it has no turret or rotor) receives 1 internal structure box for every 10 tons of the vehicle's total tonnage (rounded up).

## 7. ADD ARMOR

Armor helps protect the vehicle's internal structure. Vehicles can mount standard or ferro-fibrous armor. For each ton of standard armor selected, the vehicle has 16 Armor Points. Ferro-fibrous armor gives the vehicle more Armor Points (see **Ferro-Fibrous Armor**, p. 116 in **Equipment**).

Determine the total number of Armor Points the vehicle will carry. These points will be assigned to the vehicle's locations in Step 9. Armor can only be added in 1/2- or 1-ton lots.

## 8. ADD WEAPONS, AMMUNITION, AND OTHER EQUIPMENT

Every weapon placed on a vehicle weighs a certain amount, as shown in the Tons column of the Weapons and Equipment Table. Select the weapons and equipment that the new vehicle will carry. Add at least 1 ton (1/2 ton for machine guns) of ammo for each class of missile launcher or ballistic weapon (except one-shot weapons, which can have no additional ammo). This required extra ammo provides a varying number of shots, depending on the launcher or weapon.

Though the open construction of vehicles allows them to carry more equipment than BattleMechs, limits do exist.

Because vehicles do not have critical slots like 'Mechs, they are limited only by the total number of items they can carry, regardless of size. A vehicle can mount a base of 5 items of equipment. Because larger vehicles can carry more equipment, add 1 item to this base per 5 full tons of vehicle weight. For example, a 22-ton hovercraft can mount up to 9 items, while a 75-ton tank can mount as many as 20.

Each weapon and piece of special equipment counts as 1 item. For construction purposes, all ammunition carried for a particular type of launcher or weapon (LRM 10, AC/5, SRM 4, LRM 20) counts as 1 item, regardless of the number of tons carried. If the vehicle has a cargo hold or infantry bay, it counts as a single item, regardless of its size.

Energy weapons may require extra equipment, depending on the type of engine installed. The number of heat sinks must be equal to the number of Heat Points that all mounted energy

weapons can generate in 1 turn. Remember that all fusion plants are designed with 10 integral heat sinks built in at no cost in tonnage. The player should add more heat sinks if the vehicle's weapons require more. Vehicles combining internal combustion engines and energy weapons also require power amplifiers at a ratio of 1 ton per 10 tons of energy weapons (round up to the nearest 0.1 ton). Vehicles cannot mount double heat sinks.

Most vehicles will mount some or all of their weapons in turrets. Any number of weapons can be mounted in a turret. A vehicle may have only 1 turret, except VTOLs, which may not mount turrets. A turret weighs 10 percent of the tonnage of the mounted weapons (round up to the nearest half ton). If a weapon is not mounted in a turret, it will have a fixed arc of fire, in the direction that it is mounted.

## 9. ALLOCATE ARMOR POINTS

Divide the total number of Armor Points carried by the vehicle among the 5 locations shown on the Vehicle Record Sheet (4 for vehicles without a turret or rotor). The player chooses the exact number of Armor Points used to protect each location—the number of Armor boxes and Internal Structure boxes on the record sheet are not limitations on how much armor may be assigned to a location. However, a VTOL's rotor may carry no more than 2 points of armor.

## 10. COMPLETE THE RECORD SHEET

Fill in the remaining information on the record sheet.

Unit Type:	VEPETTE MED TANK		Driving Skill:	5
Movement Type:	TRACK	Cruising MP:	Flank MP:	Gunnery Skill:
Tonnage:	50	5	8	4
Weapons and Ammo				
Engine Rating:	Tonnage:	Fusion:	AC/5 TURRET	
250	25	<input checked="" type="checkbox"/>	AMMO (AC/5) 20 BODY	
Control Tonnage:	2.5	Lift Equipment:	MACHINE GUN FRONT	
0	0	0	AMMO (MG) 200 BODY	
Internal Structure:	5.0			
Turret:	0.8			
Armor tons:	6	Armor points:	96	
Front:			20	
Left/Right side:			18/18	
Rear:			20	
Turret:			20	

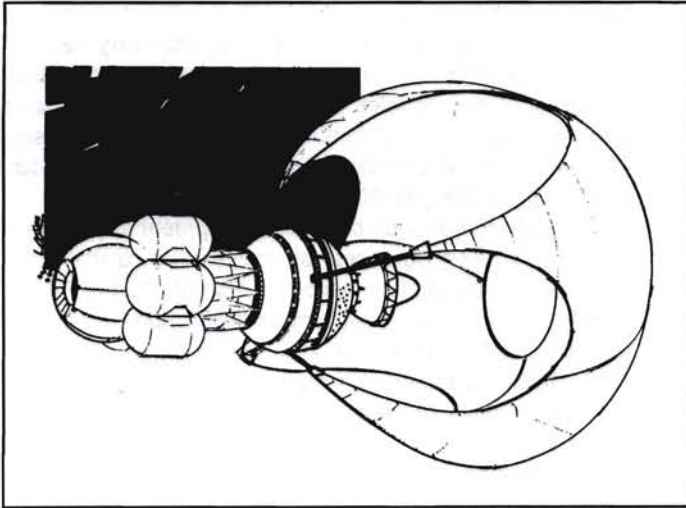

WOLFNET ARCHIVE FILE: 45792-DS9-12/5/55

From the diaries (3050–55) of J. Hunsacker, Professor Emeritus of Literature, New Avalon Institute of Science

In this age of advanced technology and interstellar travel, even I find it difficult to believe that I have reached the ripe old age of 62 without ever traveling away from the planet of my birth. It's a sad fact of life that as we age, things new and unusual make us nervous, so I did a little research to give myself a firmer grasp on the process to which I was, at long last, subjecting myself.

[Our ship jumped, and I am resuming my writing after lying down for several hours while I waited for the sensation of my skin turning inside out to subside.]

I am traveling between star systems in a DropShip connected to a JumpShip, a large, fragile vessel consisting mainly of a Kearney-Fuchida drive and a few other essentials. A special sail gathers solar energy, which powers the drive, which itself creates a hyperspace field that allows the ship to traverse up to thirty light years of space at speeds faster than light. Using this technology, JumpShips cover the immense distances between stars in seconds, usually arriving at the zenith or nadir points ("upper" and "lower" ends) of a star's gravity well, though undocumented and unguarded transport points exist deeper in each stellar system.

[A week later and fifty pages further into the primer on interstellar travel I borrowed from my grandson, who attends the NAIS.]

Commonplace during the Golden Age of the Star League, so many JumpShips were lost in the early Succession Wars that the Inner Sphere stood the risk of losing interstellar capability altogether. Rather than forfeit the ability to wage war, the various governments agreed never to attack JumpShips.

[We've jumped again. As I try to control my nausea, I hear shouts of alarm—something about WarShips. We have met the Clans, for the Succession Wars destroyed all Inner Sphere WarShips long ago. Even at the NAIS, rumors say such ships are still on the drawing boards. Explosions—the WarShip must have turned its massive weapons against us! A scream of protesting metal tells me our DropShip has detached ...]

WOLFNET ARCHIVE FILE: 44632-FG7-33/6/1

From *Border Run*, by Carvel Maxie, Firestorm Press, 3033

I didn't want to deal with DropShip negotiations. Ship captains are notoriously touchy, and my past troubles made me less than tactful. But Kelly wanted his merchandise now, so that meant getting my hands on the fastest available cargo-carrying DropShip.

The shipping manifests I'd purloined from the port's computer gave me an assortment of DropShips to choose from—luxury liners, any number of differently sized and shaped cargo haulers, and a few military transports bristling with weapons. One was a mammoth *Overlord*, carrying a battalion of 'Mechs to some godforsaken world near the truce line.

I'd picked one of the cargo ships, small and fast but packing some punch. I'd already lined up the JumpShip to get the stuff from Talley's Folly to the Endgame system, but only a DropShip could get it from Endgame's star to the planet. They're the only things sturdy enough to take the stresses of travel through planetary grav.

My appointment sat near the bar, close enough to look honest but out of the barflies' earshot. "Captain Hanson," I said, sliding into the seat across from her.

"Ms. McKay," she answered. I signaled the barkeep, who ambled over and took our order.

"So," said Hanson, when our beers arrived. "What am I carrying, where to, and by when?"

"Engine parts," I said with a straight face. "Forty tons, to Endgame. Yesterday."

"Small star," she murmured. "Take a week from here, maybe."

"Can you go faster than 1G?"

"For a price, yes." She caught my frown and elaborated. "That kind of speed's risky. I may need repairs. Shorten the trip to three days, though."

She named her price; a little high, but not as outrageous as I'd expected. A straight-shooter—or a subtler cheat than most. Gut-level, I trusted her. So I asked the final question. "You carry fighters?"

She laughed. "I'm an independent trader," she said, stressing the words. I knew what that meant. "Two *Shilones*, two *Slayers*. Topnotch pilots. And reckless enough for this job, if I understand it rightly." Hanson took a swig of beer. "So—do I pass inspection?"

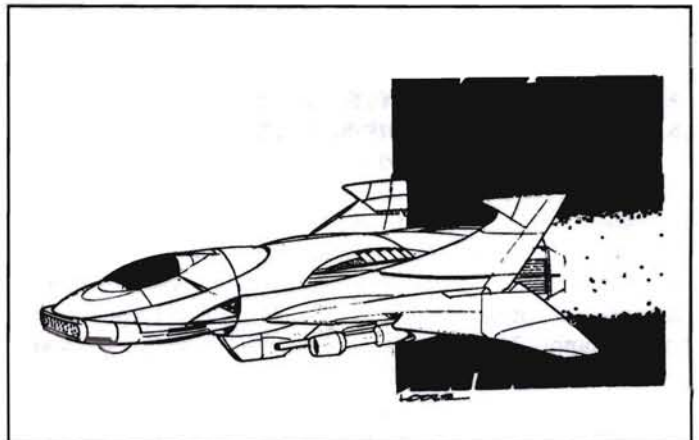

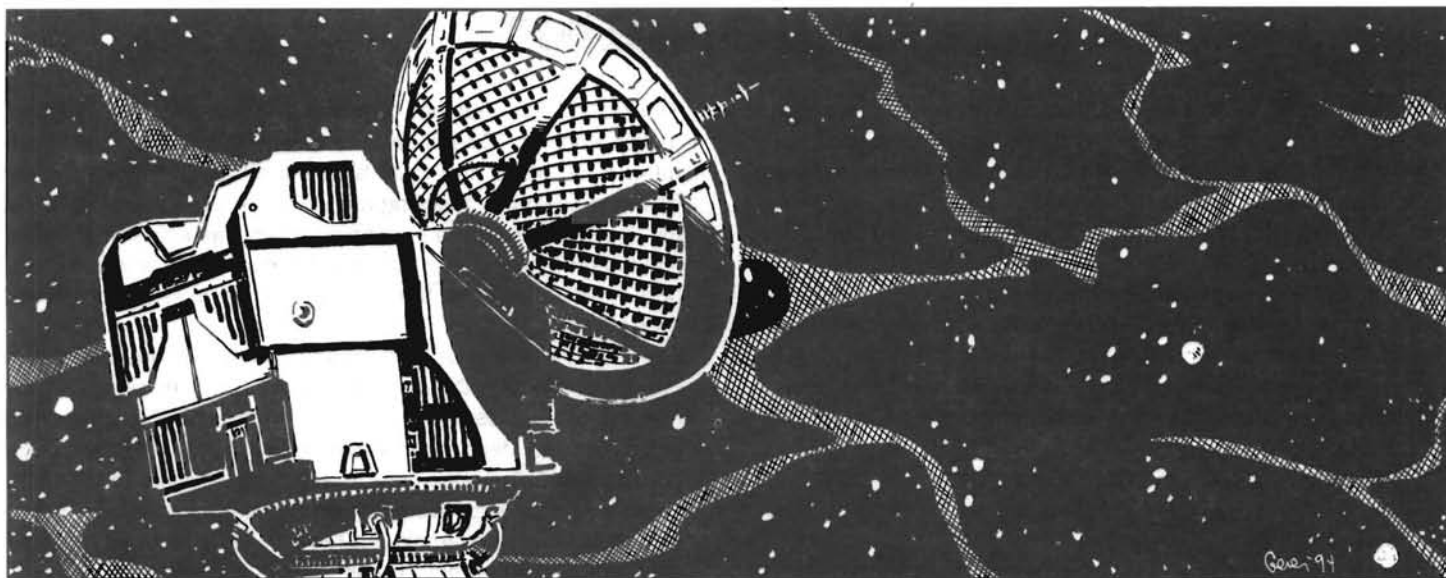

WOLFNET ARCHIVE FILE: 32211-BF5-11/17/23

Excerpted from the rediscovered *HPG Technology Readout 102-B: Hyperpulse Principles and Applications*, by Jerome Blake (Reprinted by ComStar Press, 3054)

The hyperpulse generator (HPG) operates on the same general principles of faster-than-light travel and hyperspace as a Kearny-Fuchida drive. The ComStar interstellar communications system comprises a massive network of powerful HPGs, the largest of which can instantaneously transmit or receive a signal across a distance of nearly 50 light years. More than 50 of these large facilities, called A stations, serve planets throughout the Inner Sphere. B stations, located on nearly every inhabited world in the Inner Sphere, can transmit and receive messages over a distance of 20 to 30 lightyears.

According to standard procedure, ComStar staff members process messages in the order received. HPG A stations generally transmit to each station they serve once every 12 to 24 hours, on a regular schedule. HPG B stations generally transmit only two or three times a week, always to the same A relay station. The standard length of transmission is 1 millisecond, sufficient time to send roughly two pages of text or a small image.

To cover the costs of operating, maintaining, and staffing the HPG stations, we charge a fee for the transmission service: a specific number of C-bills per transmission, the total cost for sending a message determined by the number of transmissions (the number of stations) required to reach the destination.

People who need immediate, relatively fast service (within several hours) may send priority messages, naturally at a much higher cost. A priority message is transmitted as soon as it is received, rather than sent according to the standard transmission schedule. Because a clear transmission requires perfect alignment, repositioning the HPG transmitter to communicate directly with the destination station is not the most efficient way to send a priority message. Instead, the message travels along the station's present transmission route through a series of HPGs on the shortest path to the message's destination.

WOLFNET ARCHIVE FILE: 33124-FT5-31/3/9

Excerpted from *Basic Economics*, a textbook widely used in the Free Worlds League

## A Short History of the C-bill

The C-bill, issued by ComStar in the same way that the Successor States each issue their own currencies, represents credit notes for ComStar's services. As the value of C-bills remains constant throughout the Inner Sphere, they can be used as a yardstick for all other currencies. C-bills constitute about 10 percent of the Inner Sphere's currency, their value based on a fixed amount of ComStar transmission time, service, or delivery distance.

ComStar's First Circuit approved the issuing of ComStar scrip during the reign of Primus Conrad Toyama, in the year 2835. The idea was to offer payment in kind for resources and services ComStar needed, as the order had no natural resources or land of its own upon which to base a currency. The issuance of C-bills helped to replace the unwieldy system of barter that made doing business somewhat chaotic in the days when there was no viable alternative. Because ComStar is held in high regard throughout the Successor States, their C-bills are accepted everywhere, and also serve as a medium for transferring currency, especially between enemy Houses. In short, C-bills are a handy way of transacting business between worlds of different Successor States.

The recent schism in ComStar has posed a slight problem for the C-bill, though most still regard it as the most stable currency. In anticipation of trouble to come, however, more than a few Successor State merchants are doing business with House scrip as well as with C-bills.

## EQUIPMENT

This section describes and provides rules for all weapons and equipment currently in use by Inner Sphere and occupying Clan forces. The statistics for heat produced, Damage Value, range, and tonnage of each weapon and piece of equipment appear in the Weapons and Equipment Tables in **Construction**, p. 104.

Except where otherwise indicated, the equipment in this section can be used in BattleMechs and vehicles. Both the Clans and the Inner Sphere have access to most of the technology discussed here, but the Clan versions of this equipment are generally lighter and more compact, and so considerably more efficient.

All equipment appears in alphabetical order.

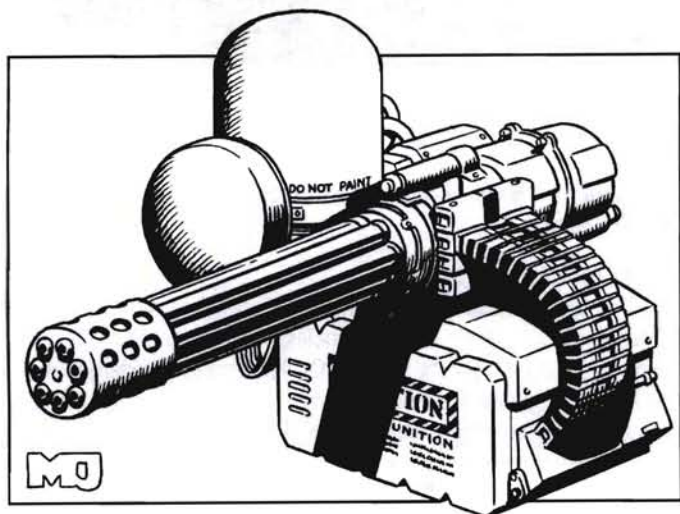

### ◆ ANTI-MISSILE SYSTEM

The anti-missile system is a rapid-fire, point-defense machine gun capable of tracking, engaging, and destroying incoming missiles. While very effective, the system's primary drawback is its high ammunition consumption. Both Clan and Inner Sphere anti-missile systems suffer from this handicap, though the Clans use flechette ammunition, increasing the number of rounds that can be stored in an ammo bin.

When a salvo of missiles attacks any BattleMech or vehicle equipped with an anti-missile system, the system automatically engages the salvo before the attacking player makes a to-hit roll for the missiles. Because the system engages automatically, it will attack the first salvo of missiles aimed at the defending unit each turn. A salvo is defined as all of the missiles launched from a single rack. For example, the 15 missiles launched from an LRM-15 rack are considered a salvo, as are the 2 missiles launched from a Streak SRM-2 rack.

To determine the effect of an anti-missile system, the defending player rolls 1D6 if the BattleMech is using an Inner Sphere system, or 2D6 if the anti-missile system is Clan-built.

The result is the number of missiles shot down. The defender makes another 1D6 roll and multiplies the result by 2 to determine how much anti-missile ammunition the system used shooting down the attacking missiles. If this result indicates that the system spent more ammunition than was actually available, the system is out of ammunition. As long as there was at least one shot available to fire, the number of missiles destroyed remains valid.

After the defender resolves the anti-missile fire, the attacking player resolves the attack of the surviving missiles. Use the number of missiles that survived to determine the appropriate column on the Missile Hits Table, p. 38, rounding to the closest column head. If the number of surviving missiles falls exactly between the value of two different column heads, use the smaller of the two. For example, an LRM-10 flight reduced to 9 missiles would still use the 10 column, but it would use the 6 column if it were reduced to 8 missiles. A flight reduced to 1 missile always hits with that 1 missile. A flight cannot hit with more missiles than the ones remaining after the anti-missile attack, regardless of the result of consulting the table.

The anti-missile system can be used only once per turn, and will not defend against anything but missiles. It cannot shoot down missiles aimed at any other target. The anti-missile system cannot be used against Thunder or Swarm LRMs, but can be used against a Narc pod and Streak SRMs. In the latter case, if the Streak to-hit roll fails and so the missiles fail to achieve lock-on (see **Streak Short-Range Missiles**, p. 120), the results of the anti-missile system's firing are disregarded; the weapon does not fire, uses no ammunition, and does not create heat.

An anti-missile system may be "turned off" during the End Phase of any turn. While it is turned off the system will not engage any incoming missiles. Anti-missile systems that have been turned off may only be turned back on again in subsequent End Phases.

Treat anti-missile system ammo as machine gun ammo for purposes of ammo explosions.

### ANTI-PERSONNEL PODS

Anti-personnel pods (A-pods) consist of directional mines installed on the lower legs of a BattleMech—which is precisely where infantry must attack if they plan to plant explosives on the sensitive actuator mechanisms. When an A-pod is triggered, it blasts a cloud of shrapnel over an effective radius of roughly 15 meters, with a devastating effect against troops unfortunate enough to be in the open at the moment of the explosion.

Only Clan BattleMechs have access to A-pods. A-pods may only be mounted in the legs. Because A-pods are one-shot weapons, each can be used only once per game.

When infantry units make anti-Mech attacks or pointblank shots from hiding (see rules for **Anti-BattleMech Infantry**, p.

## EQUIPMENT

75, and **Hidden Units**, p. 89 in **Special Case Rules**), a BattleMech with an A-pod can defend itself by detonating the pod before the infantry player makes the to-hit roll. If the defender triggers an A-pod, any unarmored infantry platoon in the same hex as the BattleMech takes 1D6 – 1 points of damage before resolving its own attack. (This is an exception to the rule prohibiting weapons fire against units in the same hex.) Regardless of the damage caused, the A-pod is expended. A-pods do not affect battle armor.

Unexpended A-pods that take a critical hit do not explode, but simply become inoperative.

### ◆ ARROW IV MISSILE ARTILLERY SYSTEM

The Arrow IV is a stand-alone missile system designed to deliver long-range salvos as a supplement to conventional artillery pieces such as the Long Tom, Thumper, and Sniper. The main advantage of the Arrow IV is its relatively light weight compared to other artillery, but its munitions are very expensive. The Clan version of this system is even higher in cost than the Inner Sphere version.

The Arrow system uses two basic types of missiles. The more common and relatively less expensive is the standard area-saturation missile, which attacks an area rather than a specific target, inflicting massive explosive damage to any object within a 45-meter blast radius.

The second type of Arrow missile is a homing missile, which homes in on a target designated by a spotting unit on the battlefield that carries target acquisition gear (TAG). The homing missile causes very little collateral damage.

Treat Arrow IV missile artillery as other artillery for game purposes, using all **Artillery** rules except as noted below.

In a standard area missile attack, note the location of the target hex and the turn of the missile's arrival on a piece of paper. Such attacks inflict 20 points of damage to all units in the impact hex and 10 points to all units adjacent to that hex. Handle scatter in the standard fashion.

Players firing homing missiles must select a specific TAG-equipped unit to act as spotter on the turn of the missile's arrival. If for any reason the selected TAG unit cannot designate the target during the Off-Board Attack Phase of the turn in which the missile arrives on the board, the missile automatically misses and explodes harmlessly.

To use TAG equipment for target designation, the spotting unit must be within 15 hexes of the target and have line of sight during the Off-Board Attack Phase of the turn of arrival. The spotting unit cannot make any attacks of its own during the arrival turn. Calculate the to-hit number based on the range from the spotting unit to the target, as for a standard weapon attack, applying all appropriate combat modifiers, including the spotting unit's movement, terrain, and so on.

If the spotter successfully designates the target (if the to-hit roll is successful) the player firing the homing missile rolls 2D6. On a result of 4 or greater, the missile hits its target. If the spotting roll fails, the missile explodes harmlessly. The missile does

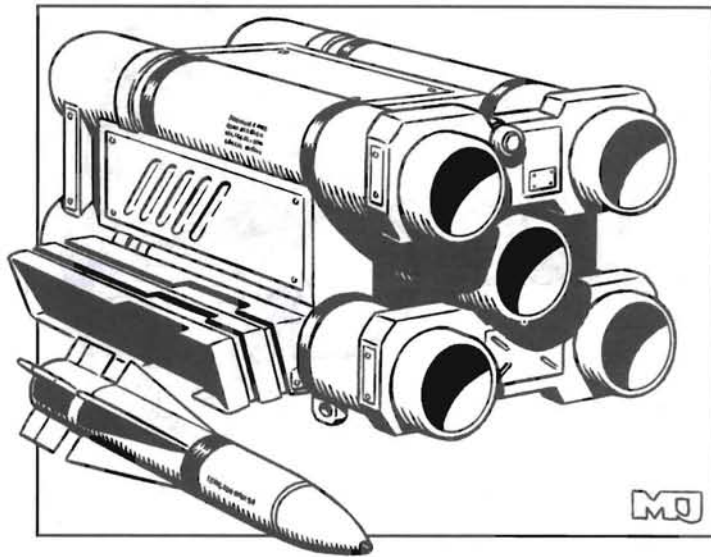

20 points of damage to one location on the target, and 5 points of artillery damage each to all other units in the hex. Homing missiles do not attack adjacent hexes or scatter. Use the location of the spotting unit relative to the target to determine the direction of the attack. For example, if, relative to the target's facing, the spotting unit is on the left side of the target, use the Left Side column of the appropriate Hit Location Table to determine what part of the BattleMech or vehicle takes the hit.

If the spotting unit successfully designates the target, but the missile misses, it causes 5 points of artillery damage each to all units in the target hex, including the target unit.

One TAG-equipped unit can act as a spotter for any number of homing missiles with the same target arriving on the same turn. Only one roll to spot is required to designate the target. However, the player must make a separate to-hit roll for each missile.

The TAG system cannot target infantry.

The Clan version of the Arrow IV system can also deliver a FASCAM round, which lays a 30-point minefield in the target hex as described in **Thunder Long-Range Missiles**, p. 121.

### ◆ ARTEMIS IV FIRE-CONTROL SYSTEM

The Artemis IV fire-control system improves the accuracy of standard missile launchers. Mounted in a dome on the side of the launcher, the Artemis locks onto a target, illuminates it with an infrared beam, and fires a spread of missiles. The system provides constant course-correction data to the missiles in flight using a tight-beam microwave communications link, which increases the number of missiles that hit the target.

Resolve any missile attack from an Artemis-equipped launcher per the standard rules. However, before consulting the Missile Hits Table, add 2 to the die roll result. This potentially increases the number of hits against the target. If the Artemis system assigned to a specific launcher is destroyed, the missile launcher can still be fired as a normal launcher.

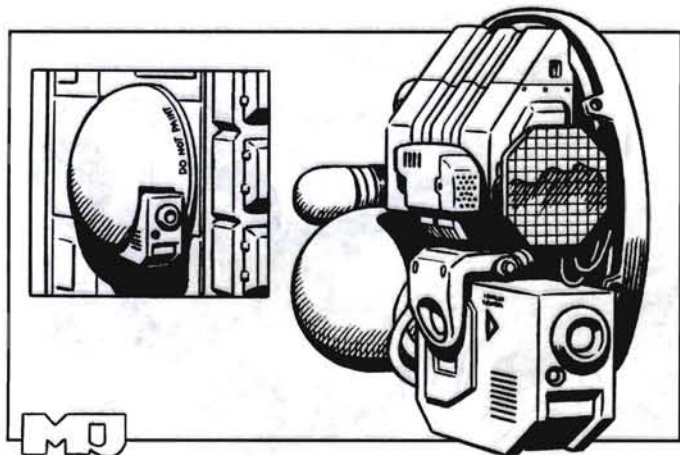

Artemis units can be attached to any standard long- or short-range missile launcher. The system must be mounted in the same location on the BattleMech as the launcher it controls (though missile launchers mounted in the center torso may be controlled by an Artemis system mounted in the head). Each launcher requires its own Artemis system. If any class of missile system (i.e., LRM or SRM) aboard the BattleMech or vehicle is outfitted with the Artemis IV, all Artemis-compatible delivery systems of that class must be equipped in the same way. The Artemis IV may only be mounted on standard missile launchers; it cannot be used with the Streak SRM, Narc missile beacon, or Swarm and Thunder munitions. It may be used with one-shot missile packs. The Artemis system uses special missiles that are identical to standard missiles for all game purposes except that they cost twice as much.

The Artemis system has no effect on LRM missiles that are fired indirectly.

## ARTILLERY WEAPONS

Generally mounted only in vehicles, but sometimes in BattleMechs, these extremely large projectile weapons enable players to launch shells at targets several kilometers away. The artillery weapons in common use are the Long Tom, Sniper, and Thumper, and the Arrow IV Missile Artillery System which uses the rules given above.

For more on artillery weapons and rules for their use, see **Artillery**, p. 77 in **Special Case Rules**.

## AUTOCANNON

An autocannon is a rapid-firing, auto-loading weapon that fires high-speed streams of high-explosive, armor-piercing shells. Light autocannon range from 30 to 90mm, and heavy autocannon may be 80 to 120mm or larger.

Autocannon are also available in advanced LB-X (p. 118) and Ultra (p. 122) versions.

## BEAGLE ACTIVE PROBE

Capable of detecting and identifying even shut-down and camouflaged units at distances much greater than standard-

issue electronic warfare (EW) suites, the active probe makes a valuable addition to any recon unit.

In **BattleTech**, the Beagle active probe will detect any hidden BattleMech or vehicle (but not infantry) if, at the end of a Movement Phase, the concealed unit lies inside the probe's operating radius (5 hexes for Clan probes and 4 hexes for Inner Sphere probes) and line of sight exists between the unit carrying the probe and the concealed unit. An active probe will not detect units hidden underwater.

Beagle active probes have no effect in the game unless the players are using the hidden units rules found on p. 89 in **Special Case Rules**.

## ◆ C<sup>3</sup> COMPUTER

Only Inner Sphere units can use the Command/Control/Communications (C<sup>3</sup>) computer system. Intended for installation in command or reconnaissance 'Mechs or vehicles, the C<sup>3</sup> system is designed to help unit commanders coordinate activities on the lance and company levels.

The C<sup>3</sup> computer system takes up 5 tons and 5 critical slots (for the "command unit") aboard the command 'Mech or vehicle, and 1 ton and 1 critical slot (for the "slave unit") aboard each 'Mech or vehicle that will have a communications link to the command computer. Each unit linked to a C<sup>3</sup> computer can use the targeting system of any other unit in the network. To make an attack using the C<sup>3</sup> computer system, calculate the to-hit number using the range to the target from the network's unit nearest the target with line of sight. Use the firing unit's modifiers for movement, terrain effects, minimum range, and so on. A weapon attack made using the C<sup>3</sup> system must conform to standard LOS restrictions and cannot fire beyond its maximum range, though a well-placed lancemate may allow the firer to use his weapon's short-range to-hit number at long range.

The C<sup>3</sup> command unit (but not the slave units) also duplicates the function of target acquisition gear (TAG) and can designate a target for Arrow IV homing missiles.

C<sup>3</sup>-equipped units spotting targets for or launching LRM indirect fire use those rules (see p. 77).

Prior to the start of play, designate which units are part of the network. Only three slave units can tie into a single C<sup>3</sup> command computer, so a typical network would be the four 'Mechs of a lance. However, the network can be extended by connecting the C<sup>3</sup> command computer on the command 'Mech of each lance in a company to a C<sup>3</sup> command computer carried by the company command 'Mech. This allows any 'Mech in the company to use the computer's coordinating effects. The complexity required to coordinate actions using this system limits any network to twelve 'Mechs, even when the network is extended by additional command vehicles. (In general practice, this means that each command computer network consists of three lances of four 'Mechs each, with a command computer and three slave computers assigned to each lance, and then two of the lance commanders slaved to the third lance commander [the company commander], who therefore has *two* command computers. The lance comman-

# EQUIPMENT

ders do *not* require slave units to connect into this network.) Different networks cannot share coordinating abilities during a battle. For example, 'Mechs of Warren's Company could not use a 'Mech of Ching's Company as a target designator even if both companies had C<sup>3</sup> networks. Loss or destruction of a unit carrying a C<sup>3</sup> command computer destroys the portion of the network it controlled.

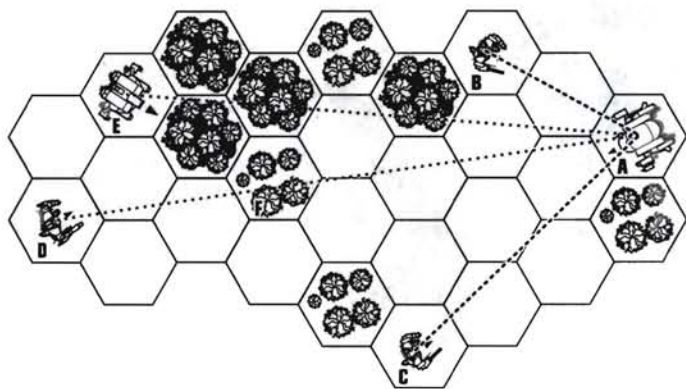

*The BattleMech in Hex A is facing enemy 'Mechs in Hexes B, C, D, and E, which are connected to a C<sup>3</sup> network. The BattleMech in Hex B is the closest to the enemy, at a Range of 2. The 'Mech in Hex C can attack as though he were at a Range of 2, provided the weapons he fires have a maximum range of 4 or more. The 'Mech in Hex D can also fire as though at a Range of 2, but must still add the terrain modifier for firing through the light woods in Hex F. The BattleMech in Hex E cannot attack the 'Mech in Hex A because no line of sight exists between the two units.*

## ◆ CARGO SPACE

During construction of any vehicle, a player may devote tonnage to cargo space. This tonnage is considered enclosed and protected by the armor of the unit. The unit may carry any cargo weighing up to this tonnage without penalty.

When the armor protecting the cargo has been destroyed, the cargo itself is destroyed at a rate of 1 ton per point of damage.

Units can drop their cargoes. During the Movement Phase, the player may declare that his unit is dumping its cargo, then spend 1 MP to do so. If the hauling unit is at ground level, the dropped cargo simply remains in the hex in which it was dropped. If the hauling unit is flying above ground level, the cargo takes normal falling damage and lands in the hex above which it was dropped.

BattleMechs cannot allocate internal space to cargo but may carry unprotected cargo per the rules for cargo carriers, p. 81 in **Special Case Rules**.

## CELLULAR AMMUNITION STORAGE EQUIPMENT (CASE)

CASE is a damage-control technology that mitigates the effects of internal ammunition explosions. When ammo explodes in a location protected by CASE, the force of the explosion blows out through specially designed panels and armor, directing the main force of the explosion away from the BattleMech's vital components, such as the cockpit or the engine.

If ammo in a CASE-equipped location explodes, it damages the weapons, internal structure, and equipment mounted in that location. Apply excess damage to the armor of the location (the rear armor, for torso locations); any remaining damage not absorbed by the armor simply dissipates. Remember that the loss of all internal structure in a side torso location also renders the corresponding arm useless. In vehicles, the CASE system blows out the rear armor; the vehicle itself is crippled, but the crew members and passengers survive the explosion.

If an ammo explosion transfers into a location protected by CASE, the internal structure in that location takes damage as normal. All excess damage is blown out the armor, as above. For example, if an Inner Sphere BattleMech suffered an arm ammo explosion and damage transferred to a side torso equipped with CASE, the internal structure of the side torso would suffer damage as normal, then the excess damage would be applied to the rear torso armor for that side. Any remaining damage would harmlessly blow out the CASE panels.

All Clan weapon pods containing ammo-fed weapons automatically have CASE, at no cost in tonnage or critical slots. Inner Sphere 'Mechs and vehicles can have CASE built in. Inner Sphere BattleMechs can only carry CASE in torso locations; Clan BattleMechs may carry CASE in any location.

An Inner Sphere CASE system requires 1 critical slot and weighs half a ton per location protected. Critical hits on locations occupied by CASE have no effect and should be rerolled.

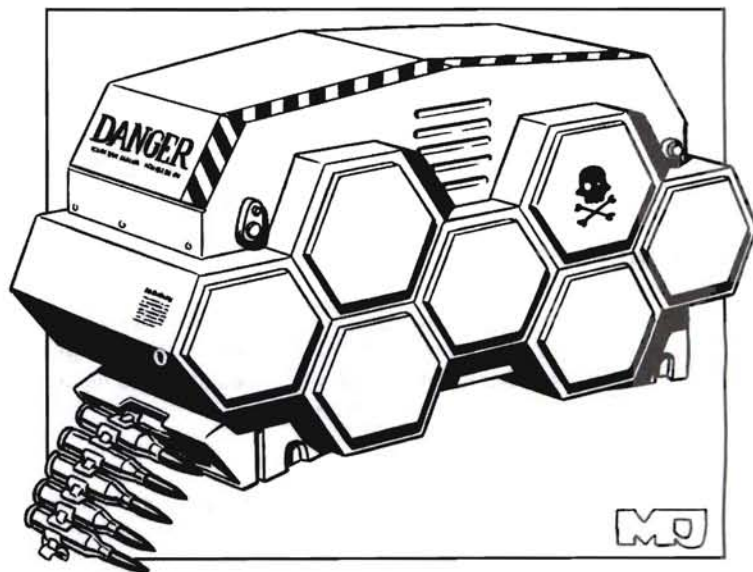

## ENDO STEEL INTERNAL STRUCTURE

Endo steel was designed especially for use in BattleMech skeletons. Using zero-G manufacturing techniques that uniformly mix high-density steel with lower density titanium and aluminum, the process produces a metal twice as strong per unit of weight as standard skeleton materials, but at an increase in overall bulk. The Clans have refined endo steel production to the point of great efficiency, but the Successor States' use of the material is still severely hampered by the scarcity of orbital manufacturing facilities.

BattleMechs built with endo steel need allocate only half the standard weight to the internal structure (rounding up to the nearest half-ton), but the bulk of the alloy takes up 7 critical slots in Clan 'Mechs and 14 in Inner Sphere BattleMechs. The player may allocate these slots wherever he sees fit, even filling up whole locations if desired, but the indicated number of slots must be filled by the endo steel. Critical hits against an endo steel critical slot have no effect and should be rerolled.

## FERRO-FIBROUS ARMOR

Ferro-fibrous armor is an improved version of ordinary BattleMech and vehicle armor that uses woven fibers of ferro-steel and ferro-titanium to greatly increase its tensile strength. However, like endo steel skeletons, ferro-fibrous armor is bulkier than standard armor plating of equivalent weight.

Units that use ferro-fibrous armor carry more Armor Points for the same weight. Calculate the normal number of Armor Points, then multiply this number by 1.12 (for Inner Sphere units) or by 1.2 (for Clan units), rounding to the nearest whole number (round .5 down). The result is the number of Armor Points of ferro-fibrous armor. To account for the bulk of the armor, place ferro-fibrous armor in 7 critical slots for Clan 'Mechs and in 14 for Inner Sphere 'Mechs. Critical hits against slots filled by ferro-fibrous armor have no effect and should be rerolled.

### FERRO-FIBROUS ARMOR

	Slots (Mech)	Items (Vehicle)	Armor Multiplier
Clan	7	1	1.2
Inner Sphere	14	2	1.12

## FLAMERS

Under normal circumstances, a flamer does not cause heat damage to a target. However, if all players agree, they may choose (each time the unit fires) to add 2 to a target BattleMech's Heat Scale for that turn as a result of the flamer attack, rather than doing 2 points of damage.

## GAUSS RIFLE

The Gauss rifle uses a series of magnets to propel a projectile through the rifle barrel toward a target. While it

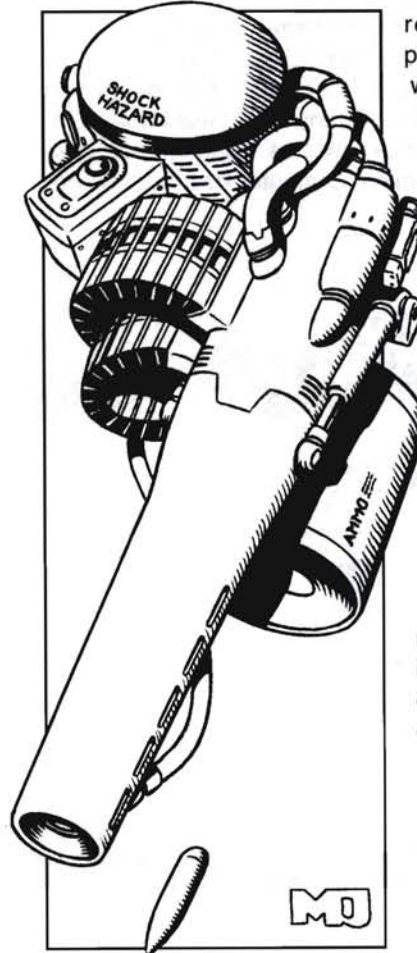

requires a great deal of power to operate, this weapon generates very little heat and can achieve a muzzle velocity twice that of any conventional weapon.

Gauss rifle ammunition consists of a slug of nickel-ferrous metal. If a location containing Gauss ammunition takes a critical hit, the ammo does not explode, but the hit destroys the ammo-feed mechanism, rendering the rest of the ammunition in that location useless.

A critical hit on the Gauss rifle itself destroys the capacitors that power the weapon, causing a catastrophic discharge of the capacitor's stored energy, with results similar to an ammunition explosion. If a Gauss rifle takes a critical hit, treat the result as a 20-point ammunition explosion in the location containing the rifle.

## ◆ GUARDIAN ECM SUITE

The Guardian ECM suite is a broad-spectrum jamming and electronic countermeasure device designed to reduce the effectiveness of enemy long-range scanning and surveillance equipment.

A Guardian system nullifies the effects of any enemy Beagle active probe (though that system would notice that it is being jammed), Artemis IV fire-control system, Narc missile beacon, or C<sup>3</sup> computer, when any of these systems are within 6 hexes of a Guardian-equipped unit. Friendly systems of these types are not affected.

The Guardian ECM suite does not affect other scanning and targeting devices, such as TAG and Clan targeting computers.

A Guardian negates the systems listed above even if they are not being used against the Guardian-equipped unit. It also affects any enemy system whose path passes within 6 hexes of the Guardian. For example, if the LOS to a Narc or the LOS between two C<sup>3</sup>-linked units passes within 6 hexes of an enemy Guardian, the line of communication is broken until the Guardian no longer interferes. If the line of communication between a C<sup>3</sup> command unit and the rest of its lance is broken, the entire network stops functioning. Individual slave units affected by a Guardian are simply cut off from the rest of the network.

Using the illustration for the C<sup>3</sup> Computer, p. 115, the situation would be quite different if the BattleMech in Hex A was equipped with a Guardian ECM suite. The 'Mechs in Hexes B and C would be cut off from the network, since they are within 6 hexes of the Guardian unit. The 'Mech in Hex D is still connected to the network, but cannot use firing data from the cut-off units or the 'Mech in Hex E, which has no LOS. Furthermore, if the C<sup>3</sup> command unit is carried by either of the 'Mechs in Hexes B or C, the entire network would collapse until they could destroy or move away from the Guardian-equipped unit.

## ◆ HATCHET

Some Inner Sphere BattleMechs come equipped with hatchets. Like other weapons, hatchets account for part of a BattleMech's weight and take up one or more locations on the Arm section of the Critical Hit Table. To use the hatchet, a BattleMech must have a functioning hand actuator in the arm in which the hatchet is mounted.

A BattleMech uses a hatchet to make physical attacks per the standard clubbing attack rules, but can make this attack with only one arm, rather than the two needed to swing a club. Though a BattleMech may mount two hatchets, one in each arm, it can only make one hatchet attack per turn. Weapons mounted on the arm not carrying the attacking hatchet may be fired in the turn's Weapon Attack Phase. Hatchets weigh 1 ton for each 15 tons, or fraction thereof, of the BattleMech's total weight. Hatchets take up 1 critical location for each ton that they weigh.

Hits on a hatchet critical location represent damage to the shaft of the weapon. If a hatchet critical location is hit, the weapon can no longer be used.

Only Inner Sphere BattleMechs are known to mount hatchets; the Clans consider physical combat to be dishonorable.

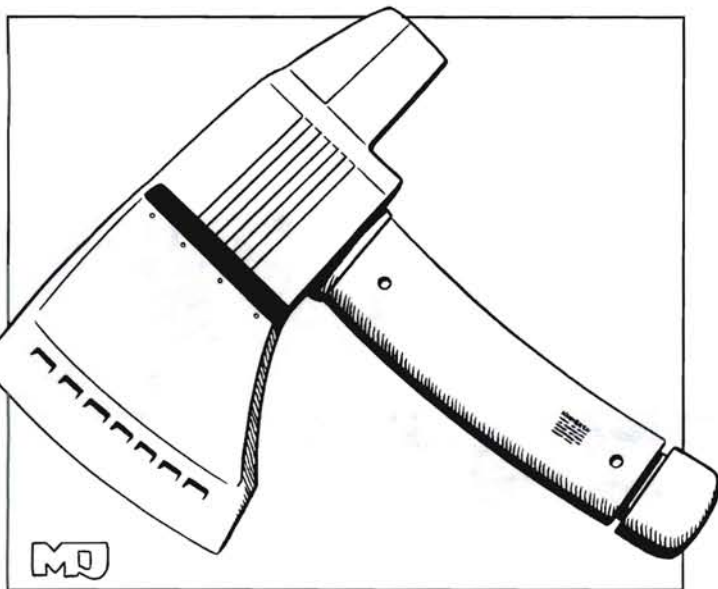

## HEAT SINKS

Heat sinks are devices designed to protect an engine and other components from heat build-up by shedding a certain amount of engine-and-weapons-generated heat. Standard heat sinks dissipate 1 point of heat per turn; double heat sinks dissipate 2 points of heat per turn.

Because they dissipate heat at twice the rate of standard heat sinks, double heat sinks cool a BattleMech much more efficiently. Though they weigh the same as standard heat sinks, the double versions are considerably bulkier, taking up extra space aboard a BattleMech. The Clan version of the double heat sink takes up twice the room of standard sinks, while the Inner Sphere model is three times as bulky.

BattleMechs with double heat sinks dissipate 2 points of heat for each operating sink each turn. If the heat sink is submerged in water, it dissipates an additional 2 points, but the maximum additional heat that can be dissipated underwater is 6 points.

Single and double heat sinks cannot be mixed in any unit. Vehicles cannot carry double heat sinks.

## ◆ INFERNOS

Infernos are special-purpose missiles designed to affect the heat level of enemy BattleMechs. Instead of impacting on a target, an inferno round explodes in midair, dispersing a highly flammable fluid over the target area. Infernos may be used against BattleMechs and vehicles, but they may not be used directly against any sort of infantry. Infernos may be used to start fires in hexes.

All players must agree on the use of infernos in a scenario or game before play begins. Infernos must be used in conjunction with the rules for fire found on p. 84 of **Special Case Rules**.

SRM-equipped infantry and any vehicle with an SRM-2 or a Streak SRM-2 can carry an inferno 2-pack instead. Though Clan units can make use of infernos, Clan battle armor troops cannot load their SRM launchers with infernos. An inferno 2-pack uses the same hit probabilities and ranges as the short-range missile system it replaces. To make an attack using inferno missiles, make a standard to-hit roll. If the attack fails, the target hex is set on fire (see below), but it has no other effect.

The heat level of a BattleMech hit by an inferno is increased by 6 points during the Heat Phase. Because the fluid sticks to the BattleMech's outer armor, this effect lasts for 3 turns, for a total heat build-up of 18 points.

Vehicles hit by an inferno attack must roll 2D6 in the Heat Phase of each of the 3 turns during which the fluid is burning. On a result of 8 or higher, the vehicle remains operational; any lower result means the vehicle is destroyed.

The hex that the target occupies is on fire whether or not the attack hit the target and regardless of the terrain type. Rough, Water, and Clear hexes are considered on fire for the rest of that turn and 3 more turns. Wooded and Building hexes are on fire for the rest of the game.

# EQUIPMENT

A unit occupying a Building hex hit by one or more infernos takes full damage from the missiles.

Additional inferno missiles hitting the same BattleMech or target hex only prolong the effect of the first hit. Thus, if two infernos hit a BattleMech, the target would suffer a heat build-up of +6 for 6 turns rather than 3.

An SRM infantry platoon hits its target with a number of inferno missiles equal to its normal damage divided by 2 (round fractions down).

BattleMechs that carry infernos must make an additional set of Heat Scale Avoid Rolls to determine whether or not the inferno ammo explodes. Make these additional rolls at the following heat levels:

## INFERNO AMMO EXPLOSION TABLE

Heat Level	Avoid Number
10	4+
14	6+
19	8+
23	10+
28	12

The inferno Avoid Rolls at 19, 23, and 28 must be made in addition to the normal Avoid Rolls required at these heat levels. If inferno ammo explodes, it adds 30 points of heat to the 'Mech, along with the standard damage from an SRM-2 explosion.

BattleMechs that take a hit from an inferno missile may stop the heat build-up by moving into water of Depth 2+ (or by going prone in Depth 1 water). Doing so rinses the flaming gel from the BattleMech and stops the heat build-up. However, the surface of the Water hex catches on fire, and it will remain on fire for the rest of that turn and 3 more turns.

### ◆ LB-X AUTOCANNON

An improvement on the common autocannon, the LB-X makes use of light, heat-dissipating alloys to reduce weight and

heat build-up. These materials make the weapon more expensive than the standard autocannon, but its advantages outweigh the higher cost.

The LB-X autocannon can fire cluster munitions, which act like an anti-BattleMech shotgun in combat. When fired, the ammunition fragments into several smaller submunitions. This improves the attacker's chances of striking a critical location, but disperses total damage by spreading hits over the target area rather than concentrating the damage on one location. Cluster munitions can be used only in LB-X autocannon, not in standard or Ultra autocannon types.

Note that the LB-X series of autocannon is not available in an Ultra configuration, and it cannot make use of that autocannon type's doubled fire rates.

Before the start of play, the player should designate any LB-X ammunition as either standard or cluster munitions. Ammo must be designated in full-ton lots. When declaring fire, the player must announce the type of ammo being used and mark it off his record sheet accordingly.

For LB-X attacks made with cluster munitions, apply a -1 modifier to the to-hit number at all ranges. Resolve successful attacks with cluster rounds like a missile hit, with the player rolling 2D6 and consulting the column of the Missile Hits Table that corresponds to the size of his LB-X autocannon to see how many submunitions strike the target. Roll a separate location for each hit, each of which causes 1 point of damage.

When firing cluster munitions, LB-X autocannons cannot be used to make aimed shots, and they also lose the benefits of the firing unit's Clan targeting computer (if any).

LB-X autocannon use all other restrictions and rules for normal autocannon of the appropriate size.

### LASER

Laser is an acronym for "Light Amplification through Stimulated Emission of Radiation." When used as a weapon, a laser damages its target by concentrating extreme heat on a small area. BattleMech lasers are designated as small, medium, and large.

Lasers are also available in extended-range (ER) versions. These types of lasers offer longer range, but at a considerably higher cost in heat.

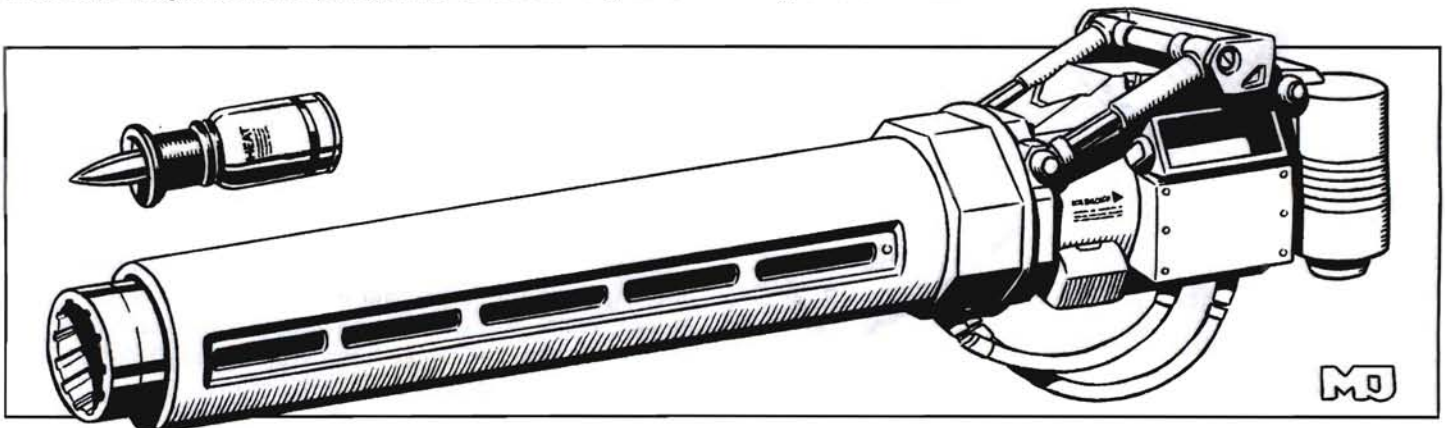

## EQUIPMENT

### LONG-RANGE MISSILES (LRM)

Long-range missile racks fire indirect salvos of high-explosive missiles at distant targets.

### MACHINE GUN

Though rarely carried by BattleMechs, the high rate of fire produced by machine guns makes them excellent anti-infantry weapons.

### ◆ MYOMER ACCELERATOR SIGNAL CIRCUITRY (MASC)

Myomer accelerator signal circuitry (MASC) allows a BattleMech to put on a short burst of speed, at some risk to its fragile leg actuators. It works by boosting the signals to the myomer leg musculature, causing those muscles to contract and relax at a quicker rate than is usually possible. This increases speed, but the stress to the actuators and myomer can cause a catastrophic failure, especially after prolonged MASC use. Note that MASC only affects leg musculature.

Any BattleMech with MASC can activate the system before the Movement Phase of any turn. The player declares that he is using the MASC system and rolls 2D6. On a result of 3 or higher, the BattleMech can run that turn at a speed equal to double its standard Walking MP. On a result of 2, the leg actuators freeze up for the rest of the game, the effects of which are identical to the 'Mech taking a critical hit to both hip actuators.

The player must roll 2D6 every turn the 'Mech is using MASC to determine whether or not the system freezes up. On the second consecutive turn of MASC use, a result of 4 or less immobilizes the BattleMech. A result of 6 or less freezes the actuators on the third consecutive turn, 10 or less on the fourth, and the legs automatically fail on the fifth turn of MASC use.

For each turn the system is not used, reduce the number at which the muscles will freeze by one step, but never below 3. For example, a player using MASC for three consecutive turns needs a result of 7 or higher on the third turn to stay mobile. After an intervening turn of not using the system, the player would need a 5 or higher to avoid freezing up. Two turns without using MASC then reduces the threshold number to the original 3.

Both Clan and Inner Sphere BattleMechs can use MASC, with the Clans gaining a slight advantage in weight and bulk. To determine tonnage and critical slot requirements for MASC, divide an Inner Sphere 'Mech's tonnage by 20, and a Clan 'Mech's tonnage by 25. Round all fractions to the nearest whole number, rounding .5 up. The result is the amount of 'Mech tonnage that must be allocated for MASC, and the number of critical slots it takes up. MASC is incompatible with triple-strength myomer.

### NARC MISSILE BEACON

The Narc missile beacon is a heavily modified missile launcher that fires special missiles, called pods, made up of powerful homing beacons mounted behind a magnetic head. If the missile hits its target, the pod broadcasts a homing signal

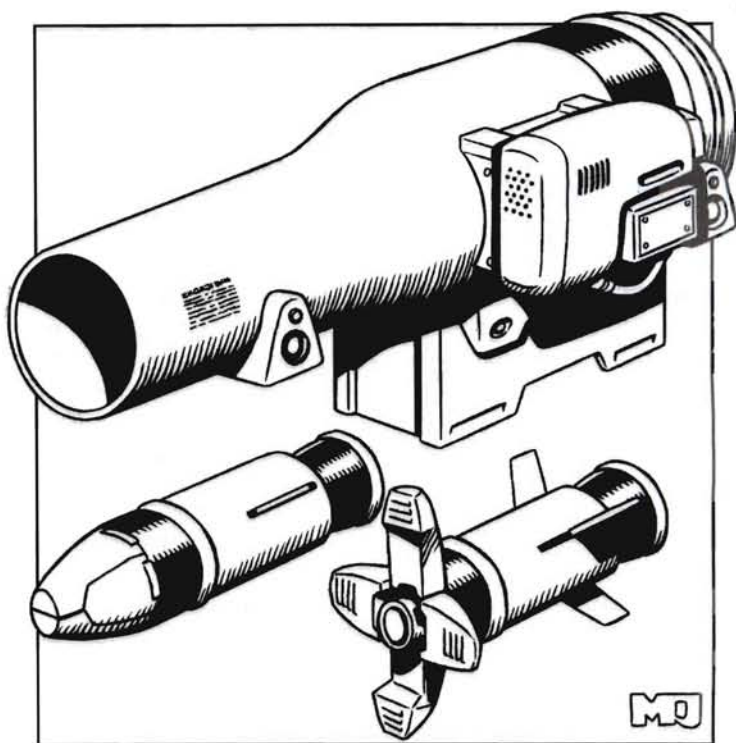

for any friendly missile systems equipped to receive Narc transmissions. Like the Artemis IV system, Narc pods potentially increase the number of missiles that hit a target. The Narc system is superior to the Artemis in that the signal lock cannot be broken once established, because the beacon is attached to the target and cannot be destroyed.

Players may fire 1 Narc pod per launcher each turn. If the attack hits, the pod is attached to the target unit. In all following combat phases, any unit attacking with Narc-equipped missiles adds +2 to the result of the roll on the Missile Hits Table. This modifier remains in effect for the targeted BattleMech for the duration of the battle.

The Narc system can be used to control both standard SRM and LRM missile attacks. It cannot affect Streak SRMs, Artemis IV, or Swarm or Thunder munitions. Missiles capable of homing in on a beacon cost twice as much as standard missiles because they carry special guidance links. Other Narc beacons in the target hex do not confuse Narc-guided missiles. Narc pods cannot be fired into or inside buildings.

Exploding Narc pods cause 2 points of damage per pod.

### PARTICLE PROJECTOR CANNON (PPC)

A particle projector cannon (PPC) consists of a magnetic accelerator firing high-energy proton or ion bolts that cause damage through both impact and high temperature. PPCs are among the most effective weapons available to BattleMechs.

PPCs also come in extended-range (ER) versions, which fire at a longer range but produce considerably higher heat.

# EQUIPMENT

## PULSE LASERS

The pulse laser uses a rapid-cycling, high-energy pulse to generate multiple laser beams, creating an effect comparable to machine-gun fire. This design improves the hit probability of laser attacks and causes more damage per hit, though at a cost of increased heat and a somewhat shorter effective range.

Treat pulse lasers the same as standard lasers, but apply a -2 modifier to the base to-hit number.

## SHORT-RANGE MISSILES (SRM)

SRMs are direct-trajectory missiles with high-explosive or armor-piercing explosive warheads. They are accurate only at ranges of less than 300 meters, but more powerful than LRMs.

## SINGLE-SHOT MISSILE LAUNCHERS

Vehicles and BattleMechs sometimes carry a single-shot version of a standard missile launcher. Such a system is designated by "OS" (one-shot) following the missile nomenclature, such as LRM-20 (OS).

The player does not purchase any ammunition for this launcher because it can be fired only once during the game. The single-shot missile launcher can be fitted to use special munitions, such as Swarm or Thunder LRM rounds, and special targeting devices (Streak, Narc, or Artemis), at double the base cost of the launcher. All other performance characteristics are the same as for multi-shot launchers of the same type and ordinance.

Single-shot launchers weigh half a ton more than the standard missile launcher of the same type.

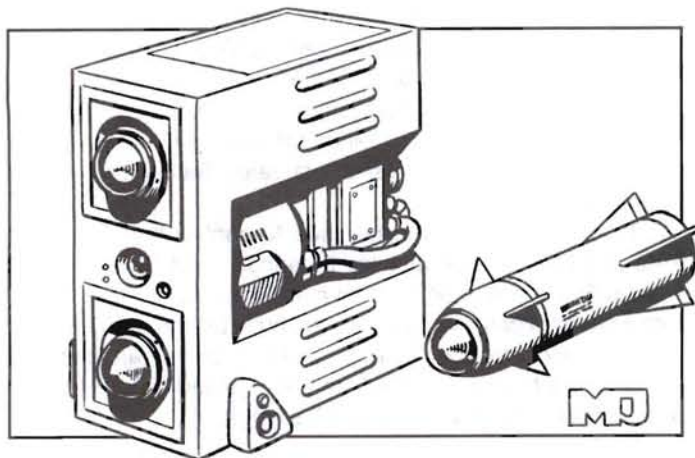

## STREAK SHORT-RANGE MISSILES

A Streak SRM missile contains a targeting device that prevents the missile from launching unless the missile has locked onto a target. Once locked on, the missile automatically hits.

A player attempting to lock a Streak missile on target must make a standard to-hit roll during the Weapon Attack Phase as if he were firing a standard SRM. If successful, the player may immediately fire his Streak SRM at the locked-on target. All

Streak missiles automatically hit, and the player rolls as normal to determine the hit locations. If the roll fails, the player fails to achieve a lock and so does not fire the SRMs and does not build up any heat. The player must roll for a targeting lock each turn, even if he achieves a lock on the target in the previous turn. The player must make a separate to-hit roll for each individual Streak system being fired.

## SWARM LONG-RANGE MISSILES

Swarm LRMs are missiles that deploy multiple guided submunitions that are aimed at a primary target and also attack nearby units.

Players should note at the start of the game how many Swarm reloads their ammunition stock includes. Swarm ammo is only available in single-ton lots.

Fire and resolve damage for Swarm LRMs in the same way as for normal missiles, except that any Swarm missiles that miss their target attack any unit, friendly or enemy, in the same hex or any hex adjacent to the target. The unit closest to the original target is attacked first, with any missiles that miss that target attacking the next closest unit, and so on until all missiles have hit something or no more targets remain. Calculate a modified to-hit number for each new target based on range, movement, and terrain. The firing unit need not have a valid line of sight to the secondary target.

If two or more possible secondary targets are adjacent to the original target, the player controlling the original target chooses the order in which those targets are attacked. If units from both sides lie equally close to the original target, choose a target randomly.

When determining the number of missiles that hit a secondary target, compare the number of remaining missiles to the Missile Hit Table and use the column for the same or fewer missiles.

## ◆ TARGET ACQUISITION GEAR (TAG)

A spotter uses target acquisition gear (TAG) to designate a target for an attack by a homing missile fired from an Arrow IV Missile Artillery System. See the description of the Arrow IV system on p. 113 for details on its use.

Note that a BattleMech or vehicle can mount only one TAG unit.

## ◆ TARGETING COMPUTER

In addition to the various special targeting systems developed for missiles, the Clans have developed advanced targeting systems, unmatched by anything in the Inner Sphere, that can enhance the performance of the following types of direct-fire weapons: lasers, PPCs, Gauss rifles, and autocannon. This advanced targeting computer is only available to Clan units.

To make an attack using the targeting computer, use all standard rules for weapons of that type, but modify the to-hit number for any attack using the unit's direct-fire weapons by -1.

The player may use the targeting computer to attempt to attack a specific hit location. All direct-fire weapons used for this type of attack must fire at the same location, which must be

visible to the firing unit. For example, an attack on the right side of the target cannot be directed against the left arm, left leg, or left torso. Because the player is effectively making a called shot, add a +3 modifier to the to-hit number for all weapons. (This modifier replaces the -1 modifier applied to standard attacks using this technology.) The head of a 'Mech may never be targeted in this manner.

The size and weight of an advanced targeting computer depends on the amount of direct-fire weaponry it will control. For every 5 tons or fraction thereof of direct-fire weapons it will control, the targeting computer requires 1 ton and 1 critical space.

## ◆ THUNDER LONG-RANGE MISSILES

Thunder LRMs deliver minefields that scatter. The "Thunder" warhead is the Inner Sphere designation for FASCAM (Field Artillery Scatterable Mines) and the Clans use a virtually identical warhead.

Players should note the number of tons of LRM ammo set aside as Thunder-FASCAM munitions before beginning play. Ammo must be designated in full-ton lots.

Thunder LRMs attack hexes rather than units. Modify the to-hit roll for these attacks for intervening terrain and the attacking unit's movement and condition only, never for the movement or condition of units in the target hex or for firing at an immobile target. If the attack misses the target hex, it scatters per the artillery rules, p. 77 of **Special Case Rules**. The hex hit by a Thunder LRM attack is considered mined from that point on by a conventional minefield equal in strength to the number of missiles in the attack. An LRM-20 will lay a 20-point minefield, while an LRM-5 lays a 5-point field. Like other conventional minefields, a Thunder minefield remains active and can make any number of attacks throughout the game, unless

cleared (see **Clearing Minefields**, p. 93 of **Special Case Rules**).

A unit that occupies a hex during the same round that hex is targeted with a Thunder LRM is not subject to a mine attack on leaving the hex. Because the unit's pilot or crew can easily see where the missile scatters its mines, the unit may safely exit the hex.

Any unit that attempts to move into a mined hex must roll 2D6 to determine if it encounters mines. On a result of 7 or more the unit hits a mine. The Damage Value varies according to the size of the LRM launcher. An LRM-15 will lay a field that does 15 points of damage, while an LRM-5 lays a field that inflicts 5 points of damage. Group the damage from a Thunder minefield into 5-point clusters, with each cluster hitting a different location. Use the Front column of the hit location table, with BattleMechs taking damage using the BattleMech Kick Location Table.

A Thunder LRM cannot deliver a command-detonated or vibrobomb field.

Add together the damage of multiple Thunder minefields in the same hex, but the total Damage Value in a hex cannot be greater than 20.

The Thunder-FASCAM missile is identical to a standard LRM round, except that it costs twice as much as standard rounds. Thunder missiles do not gain any advantages from working with a missile targeting system (Artemis IV or Narc).

## TORPEDOES

Torpedoes are maritime versions of regular short- and long-range missiles. Torpedo stats are the same as the stats of their land-based counterparts. However, torpedoes may only be fired by a unit in a Water hex of Depth 1 or greater, against a target in a Water hex of Depth 1 or greater, and LOS must be traced through Water hexes of Depth 1 or greater. Units equipped with torpedo racks may not use normal missile ammo, and missile racks may not use torpedo ammunition.

For more on underwater combat, see **Underwater Operations**, p. 95 of **Special Case Rules**.

## ◆ TRIPLE-STRENGTH MYOMER

Inner Sphere scientists have developed a special type of myomer "muscle" that becomes exceedingly strong when a 'Mech overheats. This technology is not available to Clan BattleMechs.

Triple-strength myomer provides a benefit only when a BattleMech is running hot. If a BattleMech is equipped with triple-strength myomer, for each turn that it ends with a heat level of 9 or higher, the following effects take place the next turn:

- Ignore the -1 MP heat effect at 5 on the Heat Scale (but apply all other heat modifiers to movement). In addition, increase the 'Mech's Walking MP by 1 and recalculate its Running MP accordingly. Triple-strength myomer does not affect Jumping MP.
- Double the damage for punching, kicking, clubbing, and hatchet attacks.
- Double the 'Mech's lifting ability.

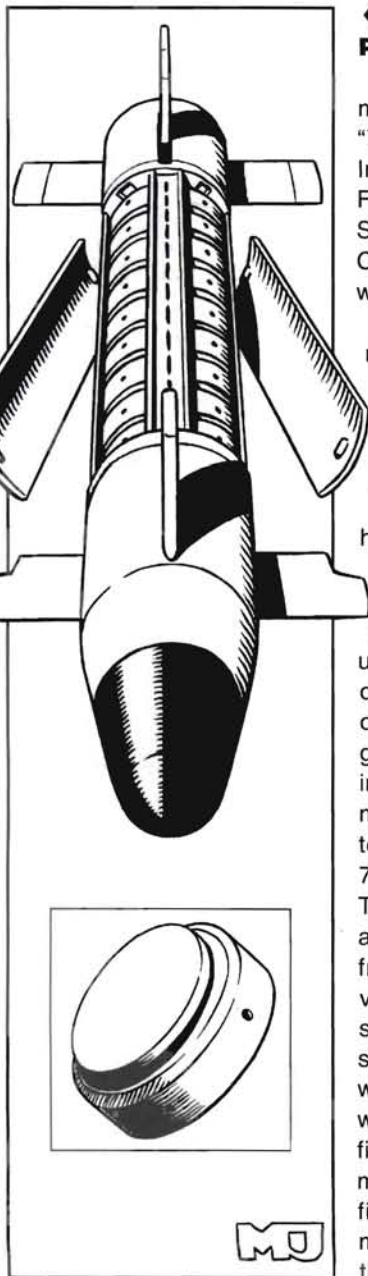

## EQUIPMENT

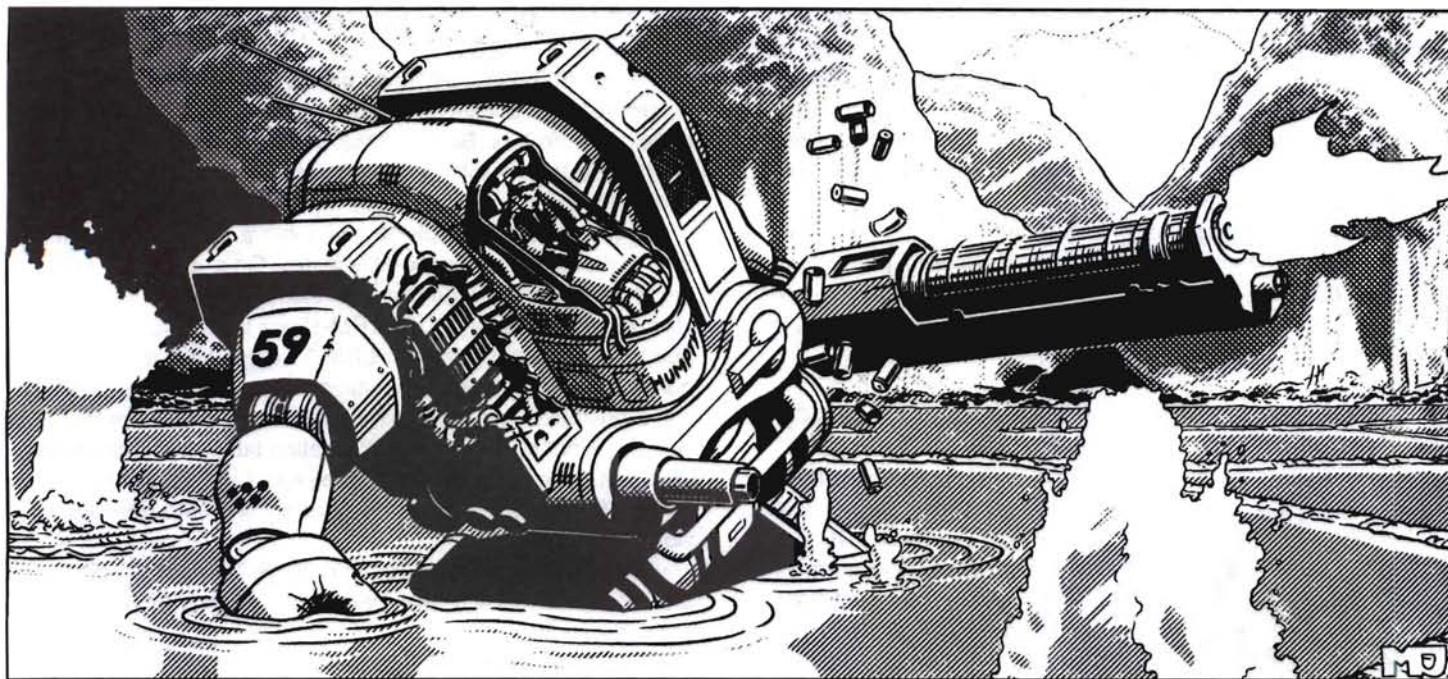

Triple-strength myomer cannot be used with MASC, and it takes up 6 critical slots. Critical hits against these slots have no effect and are rerolled.

### ◆ ULTRA AUTOCANNON

A player firing an Ultra autocannon must specify whether it is firing at a normal or double rate of fire. If firing normally, all standard combat rules apply. If firing at a double rate, use the following special rules.

An Ultra autocannon firing at a double rate generates twice as much heat and uses 2 shots of ammunition instead of 1. If the standard to-hit roll is successful, the player rolls on the "2" column of the Missile Hits Table to determine how many shots struck the target. Roll separately for a hit location for each attack; each hit inflicts the full amount of damage possible for an autocannon of the size used. Both shots must be fired at the same target.

If the firing unit is using a Clan targeting computer to aim at a specific hit location, and both shots hit, both shots hit the targeted location.

If a player is using the double rate of fire and rolls a result of 2 on his to-hit roll, the autocannon's arming circuitry fails, making the weapon useless until repaired after the battle. For

repair purposes, the autocannon is considered to have suffered 1 critical hit.

Ultra autocannon follow all other restrictions and rules for standard autocannon of the same size.

### ◆ XL ENGINES

Advances in fusion power-plant shielding have allowed engineers to retro-fit standard engines with new and lighter shielding materials, greatly reducing overall engine weight, but at the cost of compactness. The Clan version of the XL engine is much less bulky than those developed so far in the Inner Sphere.

Players may designate any fusion plant as being built with XL technology. Halve the normal engine weight (rounding up to the half-ton), and allocate additional engine critical slots to both the right and left torsos as shown in the XL Engines Table. XL engines may be equipped with either standard or double heat sinks.

Note that any 3 engine critical hits destroys a BattleMech regardless of whether the critical slots are in the side or center torso.

All BattleMechs and vehicles can use XL engines.

### XL ENGINES TABLE

	Engine Tons	Critical Slots ('Mech)	Item Slots (Vehicle)
Clan	Half Standard	2 in LT, 2 in RT	1
Inner Sphere	Half Standard	3 in LT, 3 in RT	2

# BATTLETECH COMPENDIUM

## COSTS

Players who need to buy new equipment, repair damaged units, or replace destroyed infantry must have the resources available to do so. The **Costs** section assigns a price in C-bills to all parts of a BattleMech or vehicle and replacement costs for various

infantry types. (See also descriptions of individual weapons and equipment in **Equipment**, beginning on p. 112.) For more information on unit purchases, see **Mercenary's Handbook: 3055**.

### BATTLEMECH COST TABLE

Structural Cost	Formula or Cost (in C-bills)
Cockpit	200,000
Life Support	50,000
Sensors (1/BattleMech)	Tonnage x 2,000
Musculature	
Standard	Tonnage x 2,000
Triple-Strength	Tonnage x 16,000
Internal Structure Skeleton	
Standard	Tonnage x 400
Endo Steel	Tonnage x 1,600
Arm Actuators (each)	
Upper	Tonnage x 100
Lower	Tonnage x 50
Hand	Tonnage x 80
Leg Actuators (each)	
Upper	Tonnage x 150
Lower	Tonnage x 80
Foot	Tonnage x 120
Engine	
Standard	(5,000 x Rating x Tonnage)/75
XL	(20,000 x Rating x Tonnage)/75
Gyro	300,000 per ton of gyro
Jump Jets	Tonnage x (Number of Jets) <sup>2</sup> x 200
Heat Sinks	
Standard	2,000 per each over 10
Double	6,000 each (including 10 that come with Engine)
Armor	
Standard	10,000 x tons of armor
Ferro-Fibrous	20,000 x tons of armor
<b>Other Costs</b>	
Weapons and Equipment	See Weapon and Equipment Prices
OmniMech Conversion Cost	(Weapon and Equipment Cost + Structural Cost) x .25

**Final BattleMech Cost Multiplier:** (Structural Cost + Weapons and Equipment Cost + OmniMech Cost) x [1 + (Tonnage/100)]

### BATTLEMECH COSTS

The cost in C-bills for a custom-designed BattleMech is the sum of the cost of all components according to the formulas listed below, multiplied by the Final BattleMech Cost Multiplier. When formulas refer to tonnage, use that of the BattleMech, except for gyros and armor. For those two components, use the individual component weight. As shown on the table at left, the Structural Cost of a BattleMech includes everything but its weapons, equipment, and OmniMech conversion cost.

### INFANTRY COSTS

Consult the Infantry Costs Table for the C-bill cost of an infantry platoon or a Point of battle armor.

### INFANTRY COSTS TABLE

Type	Cost (in C-bills)
Foot Platoon	
Rifle	600,000
Machine Gun/Flamer	800,000
Portable Lasers	1,200,000
SRM	1,400,000
Motorized Platoon	
Rifle	960,000
Machine Gun/Flamer	1,280,000
Portable Lasers	1,920,000
SRM	2,240,000
Jump Platoon	
Rifle	1,200,000
Machine Gun/Flamer	1,600,000
Portable Lasers	2,400,000
SRM	2,800,000
Battle Armor Point (Clan)	3,500,000
Battle Armor Unit (Inner Sphere)	3,000,000
Anti-Mech Training ( platoons only)	5 x normal cost

### VEHICLE COSTS

To determine the cost of a custom-designed vehicle, add the cost of all components together according to the formulas listed below. When formulas refer to tonnage, use that of the component itself, except for the engines and the final cost multiplier, which use the vehicle's total tonnage. Multiply the total Structural Cost by the Cost Multiplier to find the vehicle's final cost.

# COSTS

## VEHICLE COSTS TABLE

Structural Costs	Formula or Cost (in C-bills)
Engine	
Standard Fusion	$(5,000 \times \text{Rating} \times \text{Tons})/75$
XL	$(20,000 \times \text{Rating} \times \text{Tons})/75$
ICE	$(1,250 \times \text{Rating} \times \text{Tons})/75$
Control Components	$10,000 \times \text{Control Tonnage}$
Internal Structure	$10,000 \times \text{IS Tonnage}$
Heat Sinks (Standard)	2,000 each over 10, if fusion engine 2,000 each if ICE engine
Armor	
Standard	$10,000 \times \text{Tons of Armor}$
Ferro-Fibrous	$20,000 \times \text{Tons of Armor}$
Power Amplifiers	$20,000 \times \text{Amplifier Tonnage}$
Turret	$5,000 \times \text{Turret Tonnage}$
Lift/Dive Equipment (Hovercraft, Hydrofoils, Submarines)	$20,000 \times \text{Equipment Tonnage}$
Rotors (VTOLs)	$40,000 \times \text{Rotor Tonnage}$
Weapons and Equipment	See Weapons & Equip. Prices
<b>Cost Multipliers</b>	
Tracked	$1 + (\text{Tons}/100)$
Wheeled	$1 + (\text{Tons}/200)$
Hover	$1 + (\text{Tons}/50)$
VTOL	$1 + (\text{Tons}/30)$
Displacement Hull	$1 + (\text{Tons}/200)$
Hydrofoil	$1 + (\text{Tons}/75)$
Submarine	$1 + (\text{Tons}/50)$

## WEAPON AND EQUIPMENT PRICES

Type	Cost (unloaded)	Ammo Costs (per ton)
AC/2	75,000	1,000
AC/5	125,000	4,500
AC/10	200,000	6,000
AC/20	300,000	10,000
Anti-Missile System	100,000	2,000
Anti-Personnel Pod	1,500	—
Arrow IV System		
Standard	450,000	10,000
Homing	—	15,000
TAG	50,000	—
Artemis IV FCS	100,000	2 x normal
Beagle Active Probe	200,000	—
CASE	50,000	—
C <sup>3</sup> Command Unit	1,500,000	—
Slave Unit	250,000	—
ER Laser (Large)	200,000	—
ER Laser (Medium)	80,000	—
ER Laser (Small)	11,250	—
ER PPC	300,000	—

## WEAPON AND EQUIPMENT PRICES

Type	Cost (unloaded)	Ammo Costs (per ton)
Flamer	7,500	—
Gauss Rifle	300,000	20,000
Guardian ECM Suite	200,000	—
Hatchet (per ton)	5,000	—
Laser (Large)	100,000	—
Laser (Medium)	40,000	—
Laser (Small)	11,250	—
LB 2-X		
Standard	150,000	2,000
Cluster	—	3,300
LB 5-X		
Standard	250,000	9,000
Cluster	—	15,000
LB 10-X		
Standard	400,000	12,000
Cluster	—	20,000
LB 20-X		
Standard	600,000	20,000
Cluster	—	34,000
Long Tom	450,000	10,000
LRM 5	30,000	30,000
LRM 10	100,000	30,000
LRM 15	175,000	30,000
LRM 20	250,000	30,000
MASC	Engine Rating x MASC Tonnage x	
	1,000	—
Machine Gun	5,000	1,000
Narc Missile Beacon	100,000	6,000
PPC	200,000	—
Pulse Laser (Large)	175,000	—
Pulse Laser (Medium)	60,000	—
Pulse Laser (Small)	16,000	—
Single-Shot (OS)		
Launchers	Half normal	—
Sniper	300,000	6,000
SRM 2		
Standard	10,000	27,000
Inferno	—	13,500
SRM 4	60,000	27,000
SRM 6	80,000	27,000
Streak SRM 2	15,000	54,000
Streak SRM 4	90,000	54,000
Streak SRM 6	120,000	54,000
Swarm LRM	—	2 x normal
TAG (for Arrow IV)	50,000	—
Targeting Computer		
per ton	10,000	—
Thumper	187,500	4,500
Thunder LRM	—	2 x normal
Ultra AC/2	120,000	1,000
Ultra AC/5	200,000	9,000
Ultra AC/10	320,000	12,000
Ultra AC/20	480,000	20,000

## TECHNICAL READOUT: INNER SPHERE

The armies of the Inner Sphere have long sought technological superiority over each other. But for years, weapons designers had to content themselves with modifying existing Star League BattleMechs because they had lost the technical knowledge required to construct new designs. Later, as they rediscovered the long-lost technologies of the Star League and their own engineering expertise grew, the Inner Sphere powers began to design and manufacture new BattleMechs. The Clan invasion provided further fuel for these ongoing efforts, as the Inner Sphere militaries struggled to hold their own against advanced Clan OmniMechs. The following BattleMech designs represent the fruits of these design efforts. Whether entirely new BattleMech designs, modified Star League machines or Clan OmniMechs, the following 'Mechs represent the culmination of BattleMech evolution. (Record sheets for these designs are provided in the back of this book.)

### RVN-3L RAVEN

**Mass:** 35 tons

**Chassis:** Hellespont Type R

**Power Plant:** Hermes 210 XL

**Cruising Speed:** 64.8 kph

**Maximum Speed:** 90.7 kph

**Jump Jets:** None

**Jump Capacity:** None

**Armor:** Hellespont Lite Ferro-Fibrous with CASE

**Armament:**

1 Harpoon-6 SRM Launcher

2 Ceres Arms Medium Lasers

1 Apple Churchill Guiding Light Narc Beacon

**Manufacturer:** Hellespont Industries

**Primary Factory:** Sian

**Communications System:** Ceres Metals Model 666 with Guardian Electronic Counter-Measures

**Targeting and Tracking System:** Apple Churchill 2000 with Beagle Probe and 442x Target Acquisition Gear

### OVERVIEW

Three decades ago, House Liao introduced the *Raven*, an experimental 'Mech designed to provide a battalion or regiment with sophisticated electronic-warfare capabilities. The electronics of the original design, however, proved extremely heavy and ineffective in battle. Star League technology recovered during the past several years, however, has led to a resurrection of the design.

The revamped *Raven* is powered by a Hermes 210 XL engine, an advanced power plant that provides considerable weight savings, which in turn enables the new *Raven* to carry more ECM gear than its predecessor. The Guardian Electronic Counter-Measures helps shield the *Raven* and the rest of its unit from enemy sensors. The Beagle active probe, which meshes especially well with the design's Apple Churchill 2000 targeting system, locates even hidden enemy units.



The updated *Raven* carries an additional half-ton of armor along its front torso and arms, as well as Cellular Ammunition Storage Equipment that shields missile reloads against internal explosions.

Type: **RVN-3L Raven**

Equipment		Mass
Internal Structure:		3.5
Engine:	210 XL	4.5
Walking MP:	6	
Running MP:	9	
Jumping MP:	0	
Heat Sinks:	11	1
Gyro:		3
Cockpit:		3
Armor Factor:	81	4.5
	<i>Internal Structure</i>	<i>Armor Value</i>
Head	3	6
Center Torso	11	11
Center Torso (rear)		4
R/L Torso	8	11
R/L Torso (rear)		3
R/L Arm	6	8
R/L Leg	8	8

Weapons and Ammo:	Location	Critical	Tonnage
SRM 6	RT	2	3
Ammo (SRM) 15	LT	1	1
CASE	LT	1	0.5
Medium Laser	RA	1	1
Medium Laser	RA	1	1
Beagle Active Probe	CT	2	1.5
Guardian ECM Suite	LT	2	1.5
Narc Missile Beacon	LA	2	3
Ammo (Narc) 12	LT	2	2
TAG	RT	1	1

# TECHNICAL READOUT

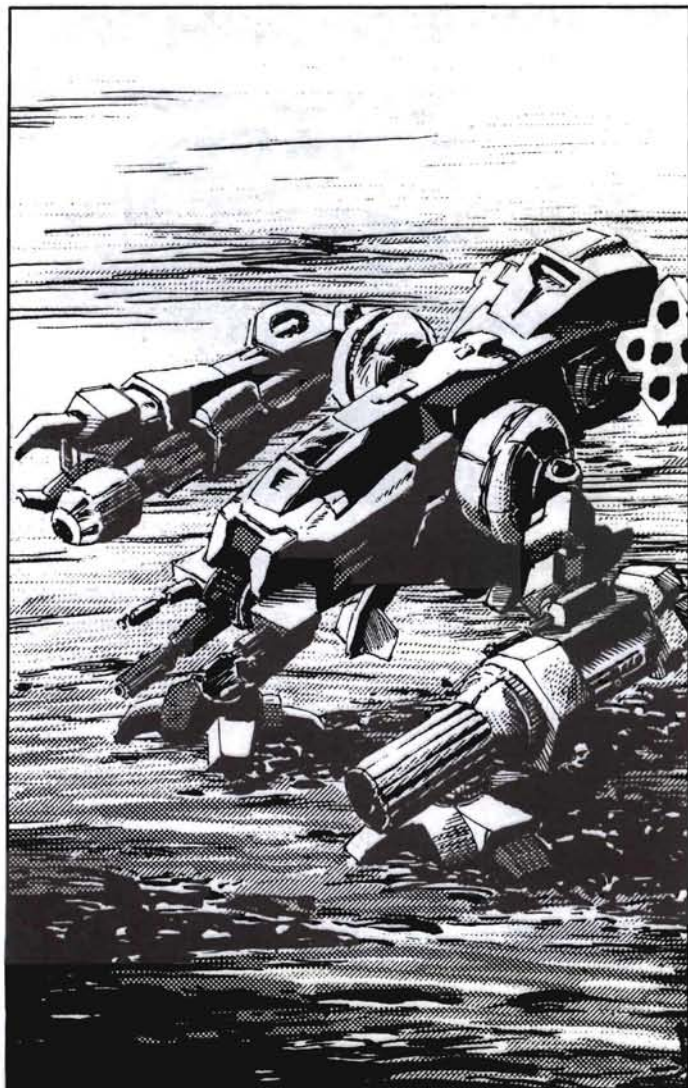

## BSW-X1 BUSHWACKER

**Mass:** 55 Tons

**Chassis:** Earthwerk GRF

**Power Plant:** Hermes 275 XL

**Cruising Speed:** 57.1 kph

**Maximum Speed:** 81.5 kph

**Jump Jets:** None

**Jump Capacity:** NA

**Armor:** Kallon Unity Weave Ferro-Fibrous with CASE

**Armament:**

2 Federated 5-Shot LRM Missile Systems

1 BlazeFire Sweetshot Extended-Range Large Laser

1 Mydron Model B Autocannon

2 Johnston MiniGuns

**Manufacturer:** TharHes Industries

**Primary Factory:** Tharkad

**Communications System:** TharHes Euterpe HM-14

**Tracking and Tracking Systems:** TharHes Ares-8a

## OVERVIEW

The prototype *Bushwacker* was under construction at the start of the Clan invasion. An ambitious, unorthodox design, the *Bushwacker* featured a long, narrow, upper torso designed to present a minimal target profile to enemy units. This unconventional configuration resulted in an extremely complex interior layout, with the 'Mech's fusion engine, sensors and communications suites crowded together. Unfortunately, the engine shielding proved insufficient to insulate the sensors and communications suites from the engine's radiation, and the *Bushwacker* experienced frequent targeting and sensor failures. Attempts to increase the engine shielding made the 'Mech too heavy and cumbersome for battle use. Although the *Bushwacker* program seems destined for cancellation, many observers have praised the innovative design as a daring work of BattleMech engineering.

Type: **BSW-X1 Bushwacker**

Equipment		Mass
Internal Structure:		5.5
Engine:	275 XL	8
Walking MP:	5	
Running MP:	8	
Jumping MP:	0	
Heat Sinks:	11 (22)	1
Gyro:		3
Cockpit:		3
Armor Factor:	161	9
	<i>Internal Structure</i>	<i>Armor Value</i>
Head	3	9
Center Torso	18	26
Center Torso (rear)		8
R/L Torso	13	22
R/L Torso (rear)		4
R/L Arm	9	11
R/L Leg	13	22

Weapons and Ammo:	Location	Critical	Tonnage
AC/10	RA	7	12
Ammo (AC) 10	RT	1	1
LRM 5	LA	1	2
ER Large Laser	CT	2	5
Machine Gun	RT	1	0.5
Machine Gun	LT	1	0.5
Ammo (MG) 100	RT	1	0.5
CASE	RT	1	0.5
LRM 5	LT	1	2
Ammo (LRM) 24	LT	1	1
CASE	LT	1	0.5

# TECHNICAL READOUT



## AXM-2N AXMAN

**Mass:** 65 tons

**Chassis:** Dorwinion Standard

**Power Plant:** General Motors 260 Extralight

**Cruising Speed:** 43.2 kph

**Maximum Speed:** 64.8 kph

**Jump Jets:** HildCo Model 12

**Jump Capacity:** 120 meters

**Armor:** Kallon Unity Weave Ferro-Fibrous with CASE

**Armament:**

2 Coventry Star Fire LRM Missile Systems

1 Sutel Precision Line Large Pulse Laser

3 Intek Medium Lasers

**Manufacturer:** Johnston Industries

**Primary Factory:** New Syrtis

**Communications System:** Johnston Wide Band

**Targeting and Tracking System:** Rander Pinpoint-HY

## OVERVIEW

The *Axman*, a larger version of Banzai Weapon Design Company's *Hatchetman*, is the culmination of years of planning and design work.

Apparently designed for widespread deployment throughout the Federated Commonwealth, the *Axman* features weapons and equipment from manufacturers in Davion and Steiner space. The *Axman* also uses Kallon Unity Weave Ferro-Fibrous Armor from a former Liao factory in the Sarna March and HildCo Model 12 Jump Jets from the St. Ives Compact.

The first *Axman* 'Mechs suffered jamming problems with their mammoth Luxor Devastator-20 Autocannons, which served as the primary weapons on the machines. In response to this problem, Banzai replaced the autocannon with two LRM-15 racks on the AXM-2N version.

Type: **AXM-2N Axman**

Equipment		Mass
Internal Structure:		6.5
Engine:	260 XL	7
Walking MP:	4	
Running MP:	6	
Jumping MP:	4	
Heat Sinks:	10 (20)	0
Gyro:		3
Cockpit:		3
Armor Factor:	179	10
	<i>Internal Structure</i>	<i>Armor Value</i>
Head	3	9
Center Torso	21	28
Center Torso (rear)		6
R/L Torso	15	21
R/L Torso (rear)		6
R/L Arm	10	17
R/L Leg	15	24

Weapons and Ammo:	Location	Critical	Tonnage
LRM 15	RT	3	7
LRM 15	LT	3	7
Ammo (LRM) 16	LT	2	2
CASE	LT	1	0.5
Medium Laser	RA	1	1
Medium Laser	RA	1	1
Medium Laser	RA	1	1
Large Pulse Laser	LA	2	7
Hatchet	RA	5	5
Jump Jets	RL	2	2
Jump Jets	LL	2	2

# TECHNICAL READOUT

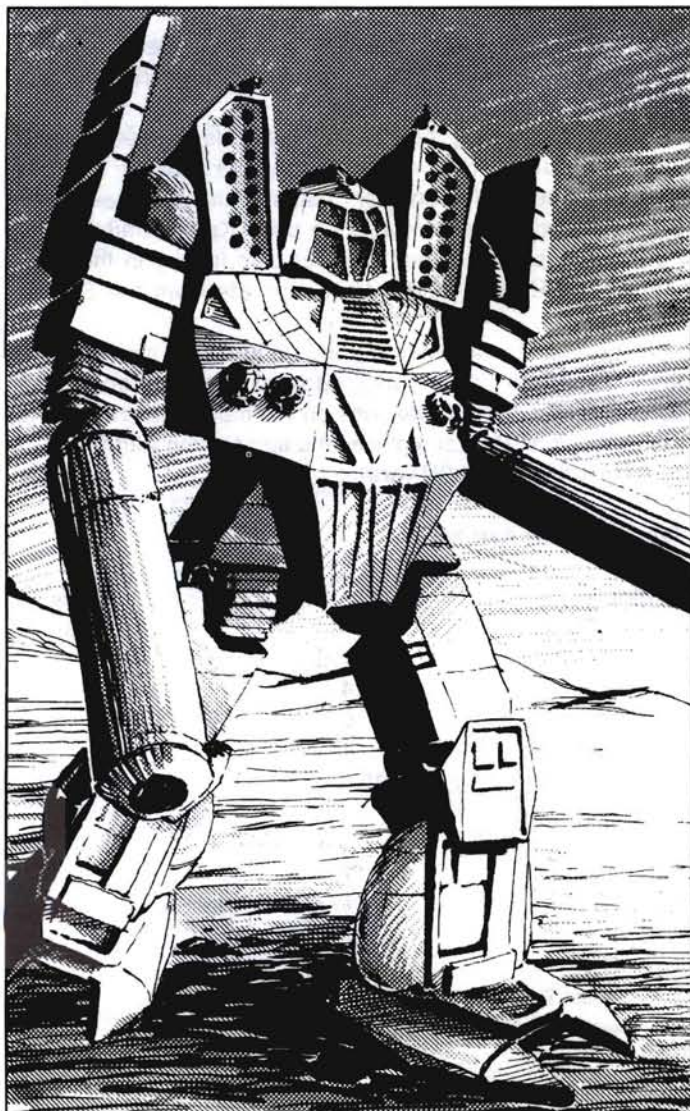

## MAL-1R MAULER

**Mass:** 90 tons

**Chassis:** Alshain Class 101

**Power Plant:** Hermes 270 XL

**Cruising Speed:** 32.4 kph

**Maximum Speed:** 54 kph

**Jump Jets:** None

**Jump Capacity:** None

**Armor:** New Samarkand Royal Ferro-Fibrous with CASE

**Armament:**

2 Victory Nickel Alloy Extended-Range Large Lasers

2 Shigunga Long Range Missile 15-Racks

4 Imperator Smoothie-2 Autocannon

**Manufacturer:** Luthien Armor Works

**Primary Factory:** Luthien

**Communications System:** Sipher Security Plus

**Targeting and Tracking System:** Matabushi Sentinel

## OVERVIEW

The *Mauler* is the Federated Commonwealth code name for a Kurita assault 'Mech that began full deployment with the DCMS recently. The advanced design features an extra-light engine, ferro-fibrous armor and double heat sinks. The *Mauler's* impressive arsenal includes arm-mounted Victory Nickel Alloy Extended-Range Large Lasers, four torso-mounted Imperator Smoothie-2 Autocannons, as well as two torso-mounted Shigunga Long Range Missile 15-Racks. The *Mauler* also features Cellular Ammunition Storage Equipment for missile reloads.

Type: **MAL-1R Mauler**

<b>Equipment</b>		<b>Mass</b>
Internal Structure:		9
Engine:	270 XL	7.5
Walking MP:	3	
Running MP:	5	
Jumping MP:	0	
Heat Sinks:	11 (22)	1
Gyro:		3
Cockpit:		3
Armor Factor:	206	11.5
	<i>Internal Structure</i>	<i>Armor Value</i>
Head	3	9
Center Torso	29	27
Center Torso (rear)		10
R/L Torso	19	26
R/L Torso (rear)		10
R/L Arm	15	22
R/L Leg	19	22

<b>Weapons and Ammo:</b>	<b>Location</b>	<b>Critical</b>	<b>Tonnage</b>
ER Large Laser	RA	2	5
ER Large Laser	LA	2	5
LRM 15	RT	3	7
Ammo (LRM) 16	RT	2	2
CASE	RT	1	0.5
LRM 15	LT	3	7
Ammo (LRM) 16	LT	2	2
CASE	LT	1	0.5
AC/2	RT	1	6
AC/2	RT	1	6
Ammo (AC) 45	RT	1	1
AC/2	LT	1	6
AC/2	LT	1	6
Ammo (AC) 45	LT	1	1

## TECHNICAL READOUT: CLAN

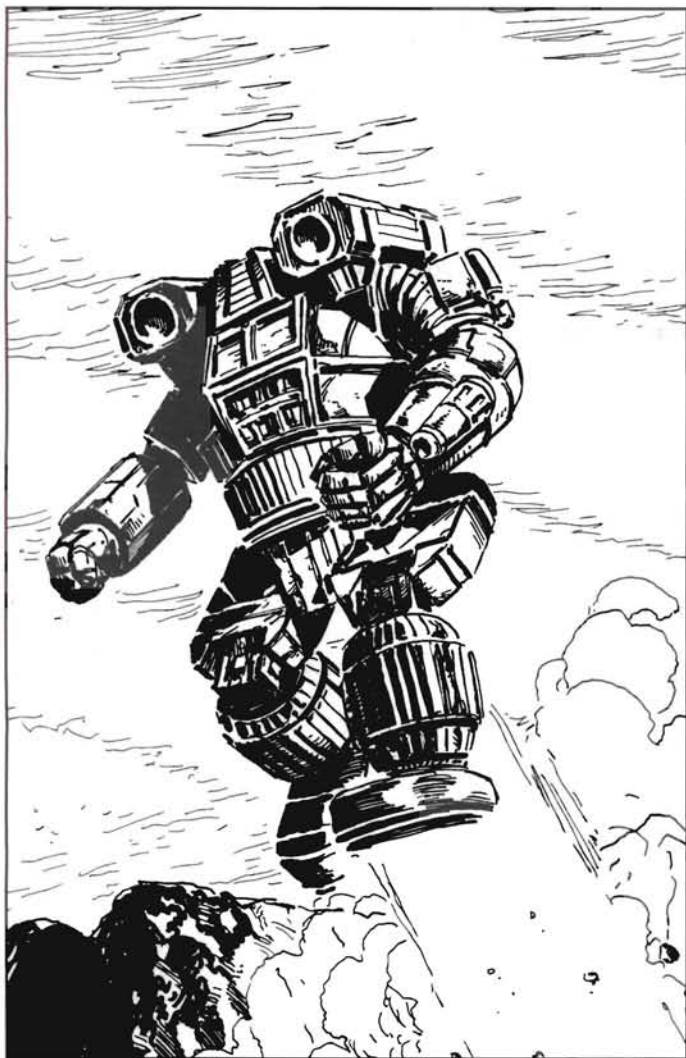

### HUNCHBACK IIC

**Mass:** 50 Tons

**Chassis:** Endo Steel

**Power Plant:** 200 XL

**Cruising Speed:** 43.9 kph

**Maximum Speed:** 63.5 kph

**Jump Jets:** 4

**Jump Capacity:** 120 meters

**Armor:** Standard

**Armament:**

2 Ultra 20 Autocannons

2 ER Medium Lasers

**Manufacturer:** Unknown

**Primary Factory:** Unknown

**Communications System:** Unknown

**Tracking and Tracking Systems:** Unknown

### OVERVIEW

The *Hunchback* IIC is a reworking of the venerable Star League-era HBK-2. The IIC mounts two rapid-fire 200mm autocannons as well as jump jets. These features make the *Hunchback* IIC a devastating close-range fighter. In closed wooded or urban terrain, the design's jump jets enable it to get into close range firing position quickly, where its twin autocannons can annihilate an opponent in seconds.

The *Hunchback* IIC has some very serious flaws, however. Like the older *Hunchback*, the IIC version has a limited ammunition load. At its full rate of fire, the *Hunchback* IIC can exhaust its supply in 20 seconds. Also, its armor is quite light for its weight class and severely limits the amount of punishment the IIC can take. As a result, *Hunchback* IICs are usually passed off to the less-prestigious freebirth or solhama units.

Type: **Hunchback IIC**

Equipment		Mass
Internal Structure:	Endo Steel	2.5
Engine:	200 XL	4.5
Walking MP:	4	
Running MP:	6	
Jumping MP:	4	
Heat Sinks:	12 [24]	2
Gyro:		2
Cockpit:		3
Armor Factor:	96	6
	<i>Internal Structure</i>	<i>Armor Value</i>
Head	3	8
Center Torso	16	18
Center Torso (rear)		4
R/L Torso	12	12
R/L Torso (rear)		3
R/L Arm	8	6
R/L Leg	12	12

Weapons and Ammo	Location	Critical	Tonnage
Ultra AC/20	RT	8	12
Ammo (AC) 5	RT	1	1
ER Medium Laser	CT	1	1
Ultra AC/20	LT	8	12
Ammo (AC) 5	LT	1	1
ER Medium Laser	CT	1	1
Jump Jets	RL	2	1
Jump Jets	LL	2	1

# TECHNICAL READOUT



## VULTURE

**Mass:** 60 tons

**Chassis:** Standard

**Power Plant:** 300 XL

**Cruising Speed:** 54 kph

**Maximum Speed:** 86.4 kph

**Jump Jets:** None

**Jump Capacity:** None

**Armor:** Ferro-Fibrous

**Armament:**

28 tons of pod space available

**Primary Weapons Configuration:**

2 Large Pulse Lasers

2 LRM 20

2 Medium Pulse Lasers

**Manufacturer:** Unknown

**Communications System:** Unknown

**Targeting and Tracking System:** Unknown

## OVERVIEW

The *Vulture* is an ungainly looking design, with noticeably "hunched" shoulders and a protruding head—features that inspired its code name. The design's hunched shoulders are created by the *Vulture*'s shoulder-mounted twin missile racks, which are supplemented by four arm-mounted lasers. In its primary configuration, the *Vulture* serves mostly as a fire-support 'Mech, an assignment the design is well suited for. In fact, many Inner Sphere MechWarriors have remarked about the

sense of foreboding inspired by the sight of a *Vulture* perched on a ridge, firing its missiles into the raging battle below.

*Vultures* were first observed serving with Clan forces in the Draconis Combine and shortly thereafter in the Free Rasalhague Republic. But the design—known among the Clans as the *Mad Dog*—has since appeared with all the different Clans. The Ghost Bears use it with the greatest frequency, but the *Vulture* is also quite popular with the warriors of the Smoke Jaguar Clan.

**Type:** Mad Dog

**Inner Sphere Designation:** *Vulture*

### Equipment

Equipment	Mass
Internal Structure:	6
Engine:	9.5
Walking MP:	5
Running MP:	8
Jumping MP:	0
Heat Sinks:	12 [24]
Gyro:	3
Cockpit:	3
Armor Factor:	163
	<i>Internal Structure</i>
	<i>Armor Value</i>
Head	3
Center Torso	20
Center Torso (rear)	7
R/L Torso	14
R/L Torso (rear)	7
R/L Arm	10
R/L Leg	14

### Weight and Space Allocation

Location	Fixed	Spaces Remaining
Head	Ferro-Fibrous	0
Center Torso		2
Right Torso	2 Engine	
	2 Ferro-Fibrous	8
Left Torso	2 Engine	
	2 Ferro-Fibrous	8
Right Arm	Ferro-Fibrous	7
Left Arm	Ferro-Fibrous	7
Right Leg		2
Left Leg		2

### Primary Weapons Configuration

Weapons and Ammo	Location	Critical	Tonnage
Large Pulse Laser	LA	2	6
Medium Pulse Laser	LA	1	2
LRM 20	LT	4	5
Ammo (LRM) 6	LT	1	1
Large Pulse Laser	RA	2	6
Medium Pulse Laser	RA	1	2
LRM 20	RT	4	5
Ammo (LRM) 6	RT	1	1

# TECHNICAL READOUT

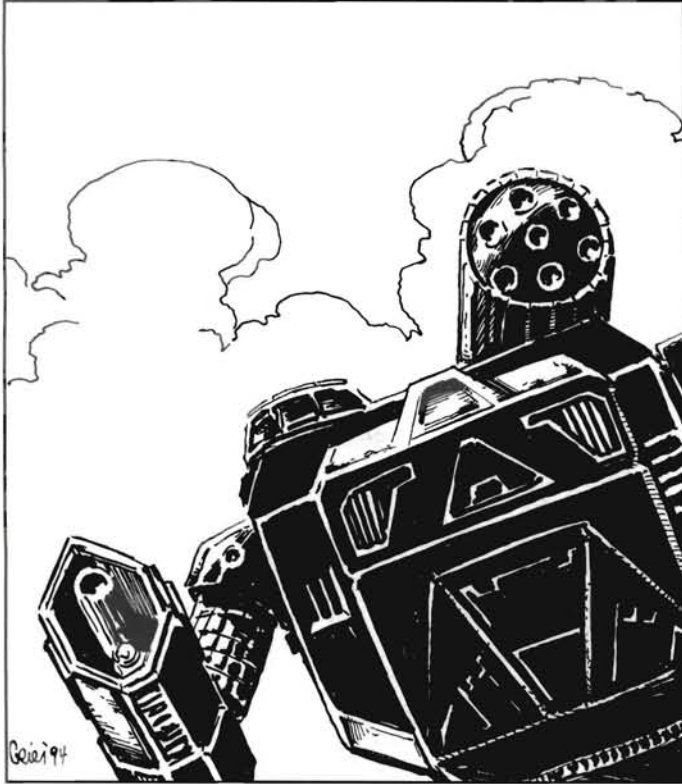

## THOR

**Mass:** 70 tons

**Chassis:** Standard

**Power Plant:** 350 XL

**Cruising Speed:** 54 kph

**Maximum Speed:** 86.4 kph

**Jump Jets:** Five

**Jump Capacity:** 150 meters

**Armor:** Ferro-Fibrous

**Armament:**

22.75 tons of pod space available

**Alternate Weapons Configuration M:**

1 Streak SRM 6

1 ER PPC

1 LB 10-X Autocannon

**Manufacturer:** Unknown

**Communications System:** Unknown

**Targeting and Tracking System:** Narc Beacon

## OVERVIEW

The *Thor* is one of the most successful heavy OmniMech designs. An excellent all-around machine, the *Thor* is noted for its mobility and its cooling system, which enables all of the design's weapons to be fired with little concern about heat buildup. Although the *Thor* may be less powerful than some designs and less nimble than others, its highly effective balance of firepower and maneuverability is matched by few other OmniMechs.

The *Thor* stands at least a meter taller than most other 'Mechs and carries a unique short-range missile launcher in its torso that actually hangs over its legs. The so-called *Thor M* also mounts a PPC in its right arm and a heavy autocannon in the left. The *Thor M* is equipped with an advanced pilot interface as well.

The *Thor*—known by the Clans as the *Summoner*—is the heaviest design in general use with the Jade Falcons, who often use their *Thors* like a quick-striking hammer to follow up a rapid advance. The other Clans also employ *Thors*, usually as mobile support for their assault 'Mechs.

Type: **Summoner**

Inner Sphere Designation: **Thor**

Equipment		Mass
Internal Structure:		7
Engine:	350 XL	15
Walking MP:	5	
Running MP:	8	
Jumping MP:	5	
Heat Sinks:	14 [28]	4
Gyro:		4
Cockpit:		3
Armor Factor:	182	9.5
	<i>Internal Structure</i>	<i>Armor Value</i>
Head	3	9
Center Torso	22	27
Center Torso (rear)		8
R/L Torso	15	22
R/L Torso (rear)		7
R/L Arm	11	17
R/L Leg	15	23

## Weight and Space Allocation

Location	Fixed	Spaces Remaining
Head	Ferro-Fibrous	0
Center Torso	Jump Jet	1
Right Torso	2 Engine	
	2 Ferro-Fibrous	8
Left Torso	2 Engine	
	2 Ferro-Fibrous	8
Right Arm	Ferro-Fibrous	7
Left Arm	Ferro-Fibrous	7
Right Leg	2 Jump Jets	0
Left Leg	2 Jump Jets	0

## Alternate Configuration M

Weapons and Ammo	Location	Critical	Tonnage
LB 10-X	LA	5	10
Ammo (LB-X) 10	LA	1	1
Streak SRM 6	LT	2	3
Ammo (SRM) 30	RT	2	2
ER PPC	RA	2	6

# TECHNICAL READOUT

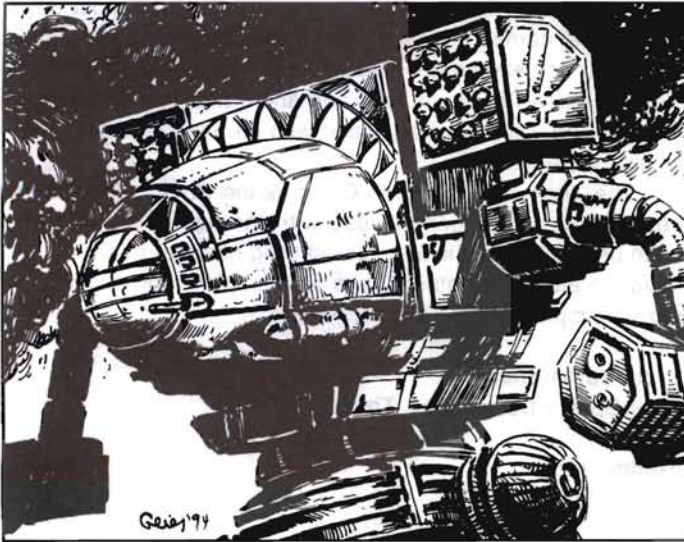

## MAD CAT

**Mass:** 75 tons

**Chassis:** Endo Steel

**Power Plant:** 375 XL

**Cruising Speed:** 54 kph

**Maximum Speed:** 86.4 kph

**Jump Jets:** None

**Jump Capacity:** None

**Armor:** Ferro-Fibrous

**Armament:**

28 tons of pod space available

**Primary Weapons Configuration:**

2 Machine Guns

2 ER Large Lasers

2 ER Medium Lasers

2 LRM 20

1 Medium Pulse Laser

**Manufacturer:** Unknown

**Communications System:** Unknown

**Targeting and Tracking System:** Unknown

## OVERVIEW

The first OmniMech to appear in the Inner Sphere was a *Mad Cat*. The design features the same hunched over torso common to both the *Marauder* and the *Catapult*, and contains an XL-class engine, endo steel internal structure, ferro-fibrous armor and double heat sinks.

The most common configuration of the *Mad Cat* carries shoulder-mounted double LRM-20 racks and extended-range large and medium lasers on its arms. The *Mad Cat* also boasts two torso-mounted pulse lasers and dual machine guns.

The *Mad Cat*, known as the *Timber Wolf* among the Clans, is the favorite 'Mech of the Wolf Clan. Undoubtedly, the devastating design has contributed greatly to the Wolves' battlefield successes, and its moderate use by other Clans remains unexplained.

Type: **Timber Wolf**

Inner Sphere Designation: **Mad Cat**

### Equipment

		Mass
Internal Structure:	Endo Steel	4
Engine:	375 XL	19.5
Walking MP:	5	
Running MP:	8	
Jumping MP:	0	
Heat Sinks:	15 [30]	5
Gyro:		4
Cockpit:		3
Armor Factor:	230	12
	<i>Internal Structure</i>	<i>Armor Value</i>
Head	3	9
Center Torso	23	36
Center Torso (rear)		9
R/L Torso	16	25
R/L Torso (rear)		7
R/L Arm	12	24
R/L Leg	16	32

### Weight and Space Allocation

Location	Fixed	Spaces Remaining
Head	Ferro-Fibrous	0
Center Torso	Endo Steel	1
Right Torso	2 Engine	
	2 Ferro-Fibrous	
	Endo Steel	7
Left Torso	2 Engine	
	2 Ferro-Fibrous	
	Endo Steel	7
Right Arm	Ferro-Fibrous	7
Left Arm	Ferro-Fibrous	7
Right Leg	2 Endo Steel	0
Left Leg	2 Endo Steel	0

### Primary Weapons Configuration

Weapons and Ammo	Location	Critical	Tonnage
Machine Gun	CT	1	.25
ER Large Laser	LA	1	4
ER Medium Laser	LA	1	1
Double Heat Sink (1)	LA	2	1
Medium Pulse Laser	LT	1	2
LRM 20	LT	4	5
Ammo (LRM) 6	LT	1	1
ER Large Laser	RA	1	4
ER Medium Laser	RA	1	1
Double Heat Sink (1)	RA	2	1
Machine Gun	RT	1	.25
Ammo (MG) 200	RT	1	1
LRM 20	RT	4	5
Ammo (LRM) 6	RT	1	1

# BATTLETECH COMPENDIUM

## INDEX

**Note:** In this index, the letters MR before a page number indicate a miniatures rule. The symbol ♦ following a page number indicates a change from previous **BattleTech Compendium** rules.

### A

- Actuator, 43, 44 ♦
- Aerospace support, 70-75 ♦
  - attacking, 70, 72
  - bombing, 73-75
  - disengaging, 72
  - game set-up, 70
  - launch and approach, 70
  - return fire, 75
  - second attacks, 72
  - strafing, 73
  - striking, 73
- Aimed shots, 39 ♦
- Ammunition
  - BattleMech, 101
  - critical hit, 43 ♦
  - dumping, 83
  - expenditures, 45 ♦
  - explosions, 17
  - heat and, 55 ♦
  - vehicle, 109
- Anti-BattleMech infantry, 75
  - leg attacks, 76
  - swarm attacks, 76-77. *See also* Swarm attack
- Anti-missile system, 112 ♦
- Anti-personnel pods (A-pods), 112-13
- Arm
  - critical hit, 42, 43, 44
  - reversing, 94
- Armor
  - BattleMech, 101
  - ferro-fibrous, 116
  - point allocation, 102, 109
  - vehicle, 109
- Armor Diagram, 9, 10
- Armored infantry, 9
- Arrow IV missile artillery system, 113 ♦
- Artemis IV fire-control system, 113-14 ♦
- Artillery, 77, MR 8
  - adjusting fire, 79
  - damage, 79
  - flak, 87
  - game set-up, 77-78
  - onboard fire, 80
  - smoke rounds, 80 ♦
  - targeting, 78-79
  - weapons, 114
- Artillery Damage Radius Table, MR 8
- Artillery Modifiers Table, 79
- Attack
  - direction, 39, MR 8

- Autocannon, 114, 118 ♦, 122
- AXM-2N *Axman*, 127

### B

- Basements, 80-81 ♦
  - Basements Table, 81
- Base To-Hit Number, 33, 34 ♦, 50
- Battle armor
  - attacks, 68-69 ♦
  - Clan, 67
  - damage to, 69
  - infantrymen, 9
  - Inner Sphere, 69
- Battle Armor Direct Fire Table, 69
- Battle Armor Missiles Table, 69
- Battle Armor Record Sheet, 11
- BattleMech Cost Table, 123
- BattleMech Hit Location Table, 39
- BattleMech Kick Location Table, 47
- BattleMech Punch Location Table, 46
- BattleMech Record Sheet, 9-10
- BattleMechs, 8
  - and buildings, 12, 56-59
  - construction of, 99-103
  - cost of, 123
  - critical hits, 42 ♦
  - damage to, 17, 41-45
  - designs, 125-28
  - destruction of, 45
  - evolution of, 28-29
  - and falls, 26-27, 51
  - four-legged, 87-88
  - heat and, 52-55
  - and hostile environments, 89-92
  - lifting capabilities, 81 ♦
  - movement of. *See* Movement
  - physical attacks, 45-52
  - prone. *See* Prone BattleMechs
  - weapon attacks and, 33-45
- Beagle active probe, 114
- Bombing, 73
  - damage, 75
  - delivery, 73, 75
  - dive bombing, 73
  - ripple bombing, 75
- Bridges, 11, 21, 23, MR 3-4
- BSW-X1 *Bushwacker*, 126
- Building Modifiers Table, 57
- Building Movement Modifiers Table, 57
- Buildings, 12, 56, MR 4
  - basements. *See* Basements
  - construction factors. *See* Construction Factors
  - damage to, 58
  - infantry in, 59, 68 ♦
  - movement effects on, 57-58
  - types, 12, 56-57
  - units inside, 58-59 ♦

### C

- C<sup>3</sup> computer, 114-15 ♦
- Capellan Confederation, 6
- Cargo
  - carriers, 81 ♦
  - space, 115 ♦
- Cellular ammunition storage equipment (CASE), 115
- Charging, 47-49
  - damage to units, 49 ♦
  - location after attack, 49
- Clan Weapons and Equipment Table, 104-5
- Clans
  - current political situation, 6
- Clubbing, 46-47
- Cockpit, 43, 109
- Combat
  - buildings and, 58-59
  - heat and, 52-55
  - infantry and, 67-69
  - Miniatures rules for, MR 6-8
  - at night, 94 ♦
  - physical attacks, 45-52
  - and four-legged BattleMechs, 87
  - vehicles and, 62-65
  - weapon attacks, 30-45 ♦
- Components
  - counters, 12-13
  - dice, 13
  - mapsheets, 11-12
  - record sheets, 9-11
  - units, 8-9
- Consciousness rolls, 17
- Construction
  - BattleMech, 99-103
  - fighter, 70
  - four-legged BattleMech, 87 ♦
  - OmniMech, 106-7
  - vehicles, 107-9
- Construction Factors (CF), 12, 23
- Control components, 100, 109
- Costs
  - of BattleMech, 123
  - of equipment, 124
  - of infantry, 123
  - movement, 18-19
  - of vehicle, 123-24
  - of weapons, 124
- Counters, 12-13
- Critical damage, 41-45
- Critical hit effects, 42-45
- Critical Hit Table, 10, 42, 101-2 ♦
- Cruising, 20
- Crusaders, 6

# INDEX

## D

- Damage, 41
  - ammo explosions, 17
  - artillery, 79
  - to battle armor, 69
  - bomb, 75
  - to buildings, 58-59
  - critical, 41-45
  - falling, 17 ♦
  - fighter, 75
  - head hit, 17
  - from heat, 17
  - to MechWarrior, 17
  - modifiers, 36
  - recording of, 41
  - transferring, 41 ♦
- Damage Transfer Diagram, 9
- Death from above, 49-50
  - damage to attacker, 50
  - damage to target, 50 ♦
  - location after attack, 50
- Dice, 13
- Domino effect, 51-52 ♦
- Draconis Combine, 6

## E

- Ejecting, 83-84 ♦
- Ejection Modifiers Table, 84
- Electronics, 106
- End Phase, 15 ♦, 17, 85. *See also* Play sequence
- Engine, 43
  - rating determination, 100, 107
  - XL, 122 ♦
- Environments, hostile, 89-92
  - extreme temperatures, 89
  - high/low gravity, 90-91 ♦
  - ice, 89-90
  - swamp, 91
  - vacuum, 91-92

## F

- Facing, 21
- Facing After a Fall Table, 27
- Falls, MR 6
  - accidental, 51
  - and BattleMechs, 49, 50 ♦
  - damage from, 27 ♦
  - facing after, 27
  - location determination after, 26
  - and MechWarriors, 27
- Federated Commonwealth, 6
- Ferro-fibrous armor, 116
- Fighter
  - attack types, 72-75
  - construction, 70
  - damage to, 75
  - movement, 70, 72

- return fire, 75
- Fires, 13, 84
  - accidental, 84
  - effects of, 85 ♦
  - intentional, 85 ♦
  - smoke, 86 ♦
  - spreading, 85-86
- Fire Table, 85
- Firing arcs, 33, MR 7
- Flak, 86-87 ♦. *See also* Artillery
- Flamers, 116
- Flank speed, 20 ♦
- Foot infantry platoon, 9
- Four-legged BattleMech, 87-88
  - and critical hits, 87
- Fourth Succession War, 6
- Free Worlds League, 6
- Fusion Engine Table, 103

## G

- Gauss rifle, 116
- Gravity, high/low, 90-91 ♦
- Ground Vehicle Critical Hits Table, 63
- Ground Vehicle Hit Location Table, 63
- Ground vehicles, 8, 60
- Guardian ECM suite, 116-17 ♦
- Gun Emplacement Damage Table, 89
- Gun emplacements, 88-89
- Gunnery Skill
  - improvement of, 17
  - rating, 16 ♦
  - varying levels, 16
- Gyro, 43 ♦

## H

- Hatchets, 46-47 CR, 117 ♦
- Head, 42, 43, 44
- Head hits, damage from, 17
- Heat, 52-53
  - build-up, 53 ♦, 88
  - damage from excess, 17
  - effects of, 53-55
  - modifier, 36
- Heat Phase, 15, 85. *See also* Play sequence
- Heat Point Table, 53
- Heat Scale, 10, 15
- Heat sinks, 43-44 ♦, 117
  - BattleMech, 101
  - double, 44
  - OmniMech, 106
- Hidden units, 89 ♦
- Hip, 44 ♦
- Hit location, 39-40, 59, 63
- Hit location tables, 10, 64, 65, 77, 87
- Hovercraft, 8, 60
- Hull integrity, 91, 98
- Hunchback IIC*, 129

## I

- Ice, 89-90
- Immobile targets, firing at, 36
- Indirect fire, LRM, 92 ♦
- Infantry, 66, 92
  - anti-BattleMech, 75-77
  - in buildings, 59, 68 ♦
  - carriers, 67
  - combat and, 67-69
  - cost of, 123
  - damage to, 67-68
  - destruction of, 45
  - movement of, 66-67
  - types of units, 9. *See also* Armored infantry, battle armor, standard infantry
- Infantry Base To-Hit Table, 67
- Infantry Costs Table, 123
- Infantry Damage in Buildings Table, 68
- Infantry Point, 9
- Infantry Record Sheet, 10-11
- Infantry Units Table, 66
- Inferno Ammo Explosion Table, 118
- Inferno rounds, 117-18 ♦
- Initiative Phase, 14. *See also* Play sequence
- Inner Sphere
  - current political situation, 6
- Inner Sphere Weapons and Equipment Table, 105-6
- Internal structure, 100-101, 109
  - endo steel, 116
- Internal Structure Diagram, 9, 41
- Internal Structure Table, 100

## J

- Jumping, 20-21 ♦
- Jump jets
  - BattleMech, 101
  - exhaust port, 44
  - OmniMech, 106
- Jump Jet Weight Table, 101
- Jump platoon, 9

## K

- Kerensky, Natasha, 6
- Kerensky, Ulric, 6
- Kicking, 47
- Kurita, Theodore, 6

## L

- Lasers, 118, 120
- Lateral shift, 87
- LB-X autocannon, 118 ♦
- LB-X cluster flak, 87 ♦
- Leg
  - attack, 76

# INDEX

critical hit, 42, 44, 87  
Leg Attacks Table, 76  
Level Two BattleTech, 7  
Levels, elevation, 18-19  
Liao, Chancellor Sun-Tzu, 6  
Life support, 44  
Line of sight (LOS), 30 ♦, MR 7  
  partial cover, effects of, 32-33 ♦  
  underwater, 97  
  water hexes, effects on, 32  
Long-range missile (LRM), 119  
Lyran Alliance, 6

## M

Machine gun, 119  
*Mad Cat*, 132  
MAL-1R *Mauler*, 128  
Mapsheets, 11-12  
Marik, Captain-General Thomas, 6  
Material, availability of, 95  
Mechanized battle armor, 67  
Mech Data, 10  
MechWarriors  
  and buildings, 57  
  Clan, skills of, 16  
  damage to, 17  
  and falls, 26-27  
  gunnery skill. *See* Gunnery skill  
  and heat, 55  
  piloting skill. *See* Piloting skill  
  skills, 15-17  
MechWarrior Consciousness Table, 17  
MechWarrior Random Skills Table, 16  
Minefields, 93-94  
  clearing, 93-94  
  command-detonated, 93  
  conventional, 93  
  types of, 93  
  vibrabomb, 93  
Miniatures  
  play rules, MR 1-8  
  preparation of, MR 2-3  
Missile hits, 38  
Modified to-hit number, 34 ♦  
Modifiers, 35-36  
Modifier tables, 23, 57, 79, 84  
Motorized infantry platoon, 9  
Movement, 18, MR 5-6  
  buildings and, 57-58  
  costs, 18-19  
  direction, 18  
  dropping to ground, 21  
  heat and, 53, 55  
  facing, 21  
  infantry and, 66-67  
  modes, 19-21  
  modifiers, 35  
  of four-legged BattleMechs, 87  
  piloting skill rolls, 24-27  
  road/pavement, 21-23 ♦  
  stacking, 24

standing up, 24 ♦  
underwater, 97  
of vehicles, 60-62. *See also* Naval  
  vessels, Vehicles, Vertical take-off  
  and landing  
Movement Cost Table, 19, MR 5  
Movement Phase, 14-15. *see also* Play  
  sequence  
Movement Point (MP), 18  
Multiple target modifier, 36  
Myomer accelerator signal circuitry  
  (MASC), 119 ♦

## N

NARC missile beacon, 119  
Naval Critical Hits Table, 63  
Naval Hit Location Table, 63  
Naval vessels, types of, 8-9  
  combat and, 63  
  movement of, 62

## O

OmniMech, 8  
  combat and, 67  
  construction of, 106-7  
  designs, 129-32  
  pods, add-on, 107

## P

Partial cover, 32-33 ♦, 36  
Particle projector cannon (PPC), 119  
Pavement, 12  
Periphery, 6  
Phases, 14-15  
Physical attacks, 45, MR 8  
  accidental falls from above, 51  
  charging, 47-49  
  clubbing, 46-47  
  death from above, 49-50  
  at different elevations, 50-51  
  domino effect, 51-52 ♦  
  kicking, 47  
  by prone BattleMech, 51 ♦  
  punching, 45-46 ♦  
  pushing, 47  
  by four-legged BattleMechs, 87  
  underwater, 98  
Physical Attack Phase, 15. *see also* Play  
  sequence  
Physical Attack Against VTOL Table, 65  
Piloting Skill  
  improvement of, 17  
  varying levels, 16  
Piloting Skill Roll, 15-16, 24-25  
  and buildings, 57  
  and facing change, 23  
  and falling, 26-27  
  and jumping, 21

making, 25-26  
  and four-legged BattleMech, 87  
Piloting Skill Roll Table, 25  
Play sequence  
  End Phase, 15 ♦  
  Heat Phase, 15  
  Initiative Phase, 14  
  Movement Phase, 14-15  
  Physical Attack Phase, 15  
  Reaction Phase, 15  
  Weapon Attack Phase, 15 ♦  
Pointblank shots, 89 ♦  
Positions, improved, 92  
Prone BattleMechs  
  attacks against, 36-37 ♦  
  firing when down, 36 ♦  
  physical attacks by, 51 ♦  
Pulse laser, 120  
Punching, 45-46 ♦  
Pushing, 47

## Q

Quad. *See* Four-legged BattleMech

## R

Range, MR 7  
Range Modifier, 35 ♦  
Reaction Phase, 15, 24, 33. *See also* Play  
  sequence  
  torso twist/turret rotation, 24  
Record sheets, 9-11, 102, 109  
Repair, 94-95  
Repair Difficulty Table, 95  
Reversing arms, 94  
Roads, MR 3-4  
Rubble, 13, MR 4  
Rules  
  miniatures conversions, MR 4-8  
  special case, 70-98  
Running, 20 ♦  
RVN-3L *Raven*, 125

## S

Scale, MR 4-5  
Scavenging, 94-95  
Sensors, 44  
Shell Flight Table, 79  
Short-range missile (SRM), 120  
Shoulder, 44  
Shutdown, effects of heat on, 55  
Sideslipping, 60  
Single-shot missile launchers, 120  
Skidding, 23 ♦  
Skid Modifier Table, 23  
Skye Rebellion, 6  
Smoke, 13, 86 ♦  
Smoke rounds, 80 ♦  
Special case rules  
  aerospace support, 70-75 ♦

# INDEX

anti-BattleMech infantry, 75-77  
artillery, 77-80  
basements, 80-81 ♦  
BattleMech lifting capabilities, 81 ♦  
cargo carriers, 81 ♦  
clearing woods, 81-82  
dropping troops, 82 ♦  
dumping ammunition, 83  
ejecting, 83-84 ♦  
fire, 84-86  
flak, 86-87  
four-legged BattleMechs, 87-88  
gun emplacements, 88-89  
hidden units, 89 ♦  
hostile environments, 89-92  
improved positions, 92  
LRM indirect fire, 92-93 ♦  
minefields, 93-94  
night combat, 94 ♦  
reversing arms, 94  
scavenging and repair, 94-95  
underwater operations, 95-98  
Special Hit Location Table, 59  
Stacking, 24, MR 6  
Standard infantry  
  attacks, 67 ♦  
  damage to, 67-68  
Standing still, 19  
Standing up, 24 ♦  
Star League, 6  
Steiner-Davion, Katrina, 6  
Steiner-Davion, Archon Prince Victor, 6  
Streak short-range missile, 120  
Striking, 73  
Submarines, 9, 10  
Successor States, 69  
Swamp, 91, MR 4  
Swarm attack, 76-77. *See also* Anti-BattleMech infantry  
  damage, 77 ♦  
  fighting off, 77  
Swarm Attacks Table, 76  
Swarm Hit Location Table, 77  
Swarm long-range missile, 120

**T**

Target acquisition gear (TAG), 120 ♦  
Targeting, 78-79  
Targeting computer, 120-21 ♦  
Target Movement To-Hit Modifiers, MR 7-8  
Technical readout  
  Clan, 129-32  
  Inner Sphere, 125-28  
Technology base, 100, 107  
Terra, 6  
Terrain  
  modifiers, 35-36  
  preparation of, MR 3-4  
  types and features of, 11-13  
Terrain Conversion Table, 82  
*Thor*, 131

Thunder long-range missile, 121 ♦  
To-hit modifiers, 35-36, MR 7-8  
To-hit numbers, 33, 34  
To-hit roll, 38  
Tonnage, 100-101, 107, 109  
Torpedoes, 121  
Torso  
  critical hit, 42, 43 ♦, 44  
  twist, 24  
Trees, MR 3  
Triple-strength myomer, 121-22 ♦  
Troops, dropping, 82 ♦  
Tukayyid, 6  
Turret rotation, 24

## U

Ultra autocannon, 122 ♦  
Unarmored infantry, 9  
Underwater Line of Sight Table, 97  
Underwater operations, 95-98  
Underwater Range Table, 97  
Units, types of, 8-9  
  destruction of, 45 ♦  
  infantry, 66-69  
  inside buildings, 58-59 ♦

## V

Vacuum, 91-92  
Vehicles  
  and buildings, 58-59 ♦  
  cargo space, 115 ♦  
  and combat, 62-65  
  construction, 107-9  
  cost of, 123  
  destruction of, 45  
  ground, 8, 60  
  infantry carriers, 67  
  movement of, 60-62. *See also*  
    Movement  
  naval, 8-9, 62, 63  
  tracked, 8  
  VTOL. *See* Vertical take-off and landing  
  weapon attack and, 33-45  
  wheeled, 8  
Vehicle Costs Table, 124  
Vehicle Data, 10  
Vehicle Record Sheet, 10  
Vehicle Table, 108  
Vertical take-off and landing (VTOL), 8, 10, 60, 64  
  combat and, 64-65  
  crashing, 60  
  engine damage, 65  
  explosions, 65  
  movement of, 60, 62  
  physical attacks against, 65  
  rotor destruction, 65  
  sideslipping, 60  
VTOL Critical Hit Table, 65

VTOL Hit Location Table, 64  
*Vulture*, 130

## W

Walking, 20  
Warrior Data, 10  
Water, 11, MR 3  
  hex, 32  
  modifier, 36  
Weapon attack, 30 ♦  
  damage, 41-45  
  effects of heat on, 55  
  firing arcs, 33  
  firing weapons, 33-37  
  hit location, 39-40  
  line of sight, 30-33 ♦  
  to-hit roll, 38  
  underwater, 97  
  unit destruction, 45  
Weapon Attack Phase, 15 ♦, 49 ♦. *See also* Play sequence  
Weapon and Equipment Prices, 124  
Weapons  
  anti-missile system, 112 ♦  
  anti-personnel pods, 112-13  
  Arrow IV missile artillery system, 113 ♦  
  artillery, 114  
  autocannon, 11  
  BattleMech, 101  
  critical hit, 45  
  flamers, 116  
  Gauss rifle, 116  
  hatchet, 117 ♦  
  infernos, 117-18 ♦  
  lasers, 118  
  LB-X autocannon, 118 ♦  
  LRM, 119  
  machine gun, 119  
  Narc missile beacon, 119  
  OmniMech, 106  
  PPC, 119  
  pulse lasers, 120  
  single-shot missile launchers, 120  
  SRMs, 120  
  Thunder LRM, 121 ♦  
  torpedoes, 121  
  Ultra autocannon, 122 ♦  
  vehicle, 109  
Weapons Fire Modifiers Table, 37  
Wheeled vehicles, 8  
Woods  
  clearing, 81-82  
  modifier, 35  
  terrain, 11  
Word of Blake, 6

## X

XL engines, 122 ♦  
XL Engine Table, 122

# BATTLETECH®

## BATTLEMECH RECORD SHEET

### ARMOR DIAGRAM

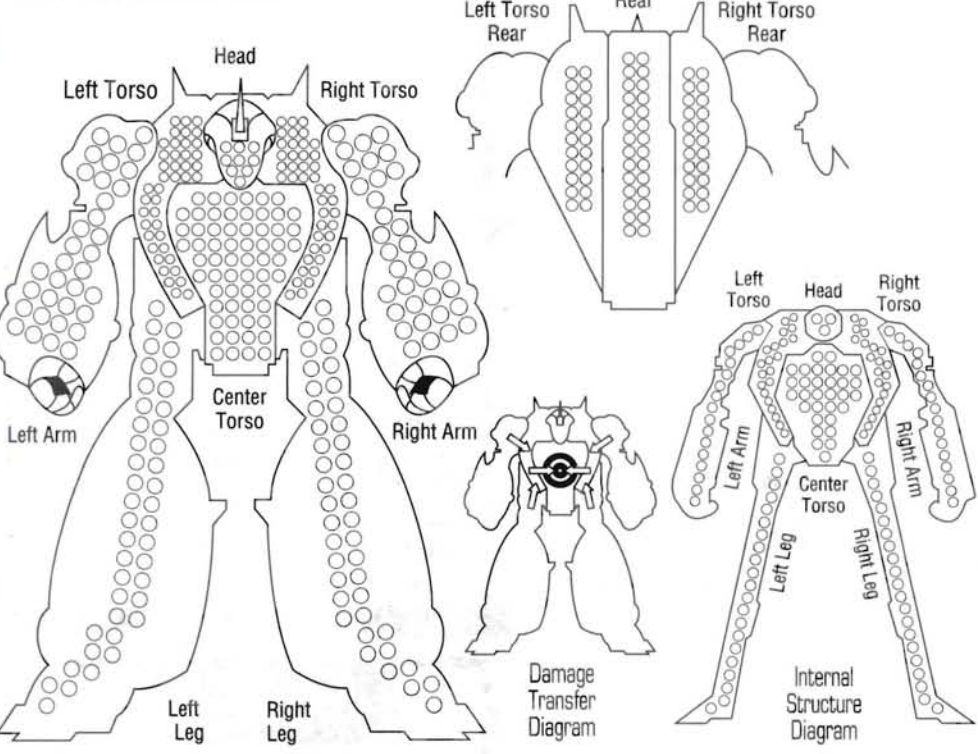

### Mech Data

Type: \_\_\_\_\_ Tonnage: \_\_\_\_\_  
 Movement Points: \_\_\_\_\_ Technology Base: \_\_\_\_\_  
 Walking: \_\_\_\_\_  Clan  
 Running: \_\_\_\_\_  Inner Sphere  
 Jumping: \_\_\_\_\_  Inner Sphere

### Weapons Inventory

Type	Location	Heat	Damage	Min.	Short	Med.	Long

**Total Heat Sinks: \_\_\_\_ ( \_\_\_\_ )**

Single  Double  
 Operational  Disabled

### Auto Eject

Operational  Disabled

### Warrior Data

Name: \_\_\_\_\_  
 Gunnery Skill: \_\_\_\_\_ Piloting Skill: \_\_\_\_\_

Hits Taken	1	2	3	4	5	6
Consciousness #	3	5	7	10	11	Dead

### Critical Hit Table

- Left Arm**
- Shoulder
  - Upper Arm Actuator
  - Lower Arm Actuator
  - Hand Actuator
- 1-3** \_\_\_\_\_  
 \_\_\_\_\_  
 \_\_\_\_\_
- 4-6** \_\_\_\_\_  
 \_\_\_\_\_  
 \_\_\_\_\_  
 \_\_\_\_\_
- Left Torso**
- \_\_\_\_\_
  - \_\_\_\_\_
  - \_\_\_\_\_
  - \_\_\_\_\_
  - \_\_\_\_\_
  - \_\_\_\_\_
- 1-3** \_\_\_\_\_  
 \_\_\_\_\_  
 \_\_\_\_\_  
 \_\_\_\_\_
- 4-6** \_\_\_\_\_  
 \_\_\_\_\_  
 \_\_\_\_\_  
 \_\_\_\_\_
- Left Leg**
- Hip
  - Upper Leg Actuator
  - Lower Leg Actuator
  - Foot Actuator
- \_\_\_\_\_

- Head**
- Life Support
  - Sensors
  - Cockpit
  - \_\_\_\_\_
  - Sensors
  - Life Support
- Center Torso**
- Engine
  - Engine
  - Engine
  - Gyro
  - Gyro
  - Gyro
- 1-3** \_\_\_\_\_  
 \_\_\_\_\_  
 \_\_\_\_\_
- Gyro
  - Engine
  - Engine
  - Engine
  - \_\_\_\_\_
  - \_\_\_\_\_
- 4-6** \_\_\_\_\_  
 \_\_\_\_\_  
 \_\_\_\_\_

Engine Hits	○ ○ ○
Gyro Hits	○ ○ ○
Sensor Hits	○ ○ ○
Life Support	○

Combat Value \_\_\_\_\_  
 Cost \_\_\_\_\_

- Right Arm**
- Shoulder
  - Upper Arm Actuator
  - Lower Arm Actuator
  - Hand Actuator
- 1-3** \_\_\_\_\_  
 \_\_\_\_\_  
 \_\_\_\_\_
- 4-6** \_\_\_\_\_  
 \_\_\_\_\_  
 \_\_\_\_\_  
 \_\_\_\_\_
- Right Torso**
- \_\_\_\_\_
  - \_\_\_\_\_
  - \_\_\_\_\_
  - \_\_\_\_\_
  - \_\_\_\_\_
  - \_\_\_\_\_
- 1-3** \_\_\_\_\_  
 \_\_\_\_\_  
 \_\_\_\_\_  
 \_\_\_\_\_
- 4-6** \_\_\_\_\_  
 \_\_\_\_\_  
 \_\_\_\_\_  
 \_\_\_\_\_
- Right Leg**
- Hip
  - Upper Leg Actuator
  - Lower Leg Actuator
  - Foot Actuator
- \_\_\_\_\_

### Heat Scale

30	Shutdown
29	
28	Ammo Explosion, avoid on 8+
27	
26	Shutdown, avoid on 10+
25	-5 Movement Points
24	+4 Modifier to Fire
23	Ammo Explosion, avoid on 6+
22	Shutdown, avoid on 8+
21	
20	-4 Movement Points
19	Ammo Explosion, avoid on 4+
18	Shutdown, avoid on 6+
17	+3 Modifier to Fire
16	
15	-3 Movement Points
14	Shutdown, avoid on 4+
13	+2 Modifier to fire
12	
11	
10	-2 Movement Points
09	
08	+1 Modifier to Fire
07	
06	
05	-1 Movement Points
04	
03	
02	
01	
00	

# BATTLETECH®

## QUAD BATTLEMECH RECORD SHEET

### ARMOR DIAGRAM

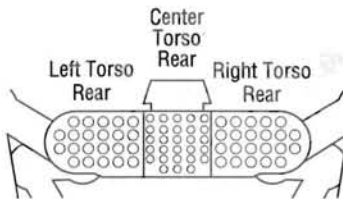
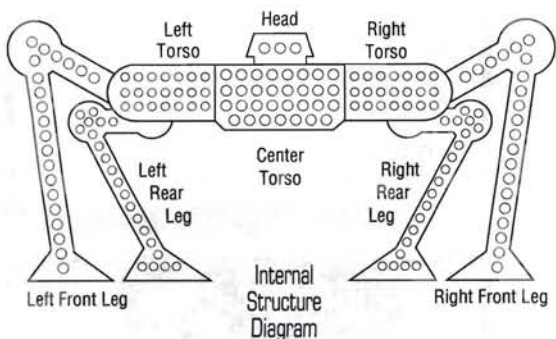
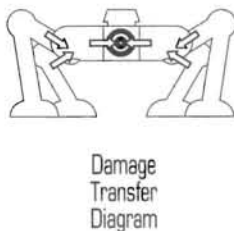
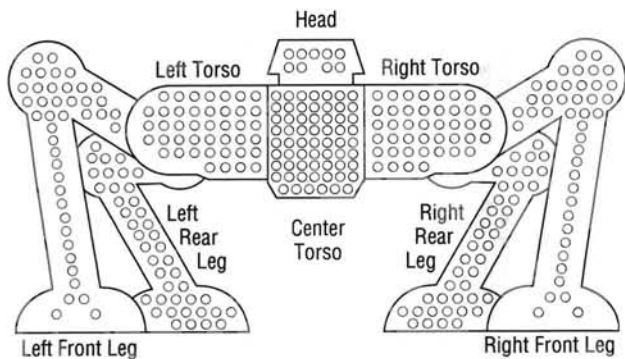

### Mech Data

Type: \_\_\_\_\_ Tonnage: \_\_\_\_\_  
 Movement Points: \_\_\_\_\_ Technology Base: \_\_\_\_\_  
 Walking: \_\_\_\_\_  Clan  
 Running: \_\_\_\_\_  Inner Sphere  
 Jumping: \_\_\_\_\_  Inner Sphere

### Weapons Inventory

Type	Location	Heat	Damage Min.	Short	Med.	Long

### Total Heat Sinks: \_\_\_\_ ( \_\_\_\_ )



### Auto Eject

Operational  Disabled

### Critical Hit Table

#### Left Front Leg

- Hip
- Upper Leg Actuator
- Lower Leg Actuator
- Foot Actuator
- \_\_\_\_\_
- \_\_\_\_\_

#### Head

- Life Support
- Sensors
- Cockpit
- \_\_\_\_\_
- Sensors
- Life Support

#### Right Front Leg

- Hip
- Upper Leg Actuator
- Lower Leg Actuator
- Foot Actuator
- \_\_\_\_\_
- \_\_\_\_\_

#### Left Torso

- \_\_\_\_\_
  - \_\_\_\_\_
  - \_\_\_\_\_
  - \_\_\_\_\_
  - \_\_\_\_\_
  - \_\_\_\_\_
- 1-3  
\_\_\_\_\_
- 4-6  
\_\_\_\_\_

#### Center Torso

- Engine
  - Engine
  - Engine
  - Gyro
  - Gyro
  - Gyro
- 1-3  
\_\_\_\_\_
- 4-6  
\_\_\_\_\_

#### Right Torso

- \_\_\_\_\_
  - \_\_\_\_\_
  - \_\_\_\_\_
  - \_\_\_\_\_
  - \_\_\_\_\_
  - \_\_\_\_\_
- 1-3  
\_\_\_\_\_
- 4-6  
\_\_\_\_\_

#### Left Rear Leg

- Hip
- Upper Leg Actuator
- Lower Leg Actuator
- Foot Actuator
- \_\_\_\_\_
- \_\_\_\_\_



Combat Value \_\_\_\_\_  
 Cost \_\_\_\_\_

#### Right Rear Leg

- Hip
- Upper Leg Actuator
- Lower Leg Actuator
- Foot Actuator
- \_\_\_\_\_
- \_\_\_\_\_

### Warrior Data

Name: \_\_\_\_\_  
 Gunnery Skill: \_\_\_\_\_ Piloting Skill: \_\_\_\_\_  
 Hits Taken 

1	2	3	4	5	6
---	---	---	---	---	---

  
 Consciousness # 

3	5	7	10	11	Dead
---	---	---	----	----	------

### Heat Scale

30	Shutdown
29	
28	Ammo Explosion, avoid on 8+
27	
26	Shutdown, avoid on 10+
25	-5 Movement Points
24	+4 Modifier to Fire
23	Ammo Explosion, avoid on 6+
22	Shutdown, avoid on 8+
21	
20	-4 Movement Points
19	Ammo Explosion, avoid on 4+
18	Shutdown, avoid on 6+
17	+3 Modifier to Fire
16	
15	-3 Movement Points
14	Shutdown, avoid on 4+
13	+2 Modifier to fire
12	
11	
10	-2 Movement Points
09	
08	+1 Modifier to Fire
07	
06	
05	-1 Movement Points
04	
03	
02	
01	
00	

# BATTLETECH®

## GROUND VEHICLE RECORD SHEET

Unit Type:			Driving Skill:		
Movement Type:	Cruising MP:	Flank MP:	Gunnery Skill:		
Tonnage:			<b>Weapons and Ammo</b>		
Engine Rating:	Tonnage:	Fusion <input type="checkbox"/>			
Control Tonnage:	Lift Equipment:				
Power Amplifier:	Heat Sinks:				
Internal Structure:					
Turret:					
Armor tons:	Armor points:				
Front:					
Left/Right side:	/				
Rear:					
Turret:					

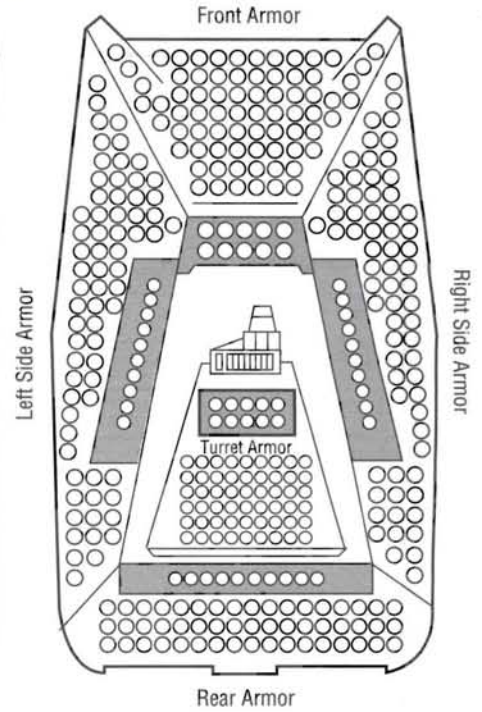

# BATTLETECH®

## V.T.O.L. RECORD SHEET

Unit Type:			Driving Skill:		
Movement Type: VTOL	Cruising MP:	Flanking MP:	Gunnery Skill:		
Tonnage:			<b>Weapons and Ammo</b>		
Engine Rating:	Tonnage:	Fusion <input type="checkbox"/>	I.C.E. <input type="checkbox"/>	Turn	Elev.
Control Tonnage:	Lift Equipment:			1	
Power Amplifier:	Heat Sinks:			2	
Internal Structure:				3	
				4	
				5	
Armor tons:	Armor points:			6	
Front:				7	
Left/Right side:	/			8	
Rear:				9	
Rotor:				10	

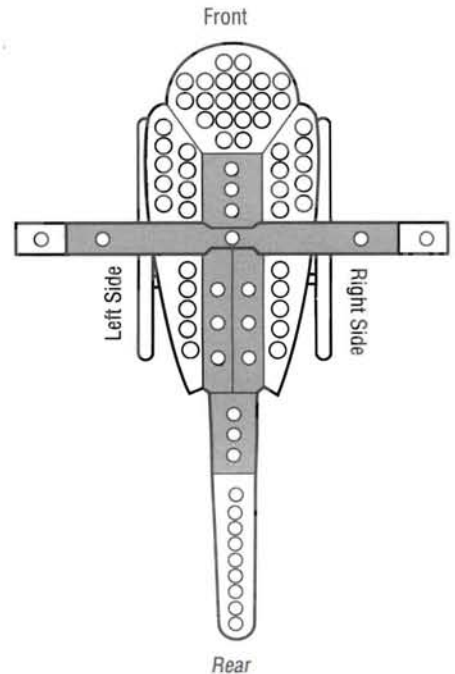

# BATTLETECH®

## NAVAL RECORD SHEET

Unit Type:				Driving Skill:		
Movement Type:		Cruising MP:	Flanking MP:	Gunnery Skill:		
Tonnage:				<b>Weapons and Ammo</b>		Turn
Engine Rating:	Tonnage:	Fusion <input type="checkbox"/>	I.C.E. <input type="checkbox"/>			1
Control Tonnage:	Lift/Diving Equipment:					2
Power Amplifier:	Heat Sinks:					3
Internal Structure:						4
Turret:						5
Armor tons:	Armor points:					6
						7
Front:						8
						9
Left/Right side:						10
						11
Rear:						12
						13
Turret:						14

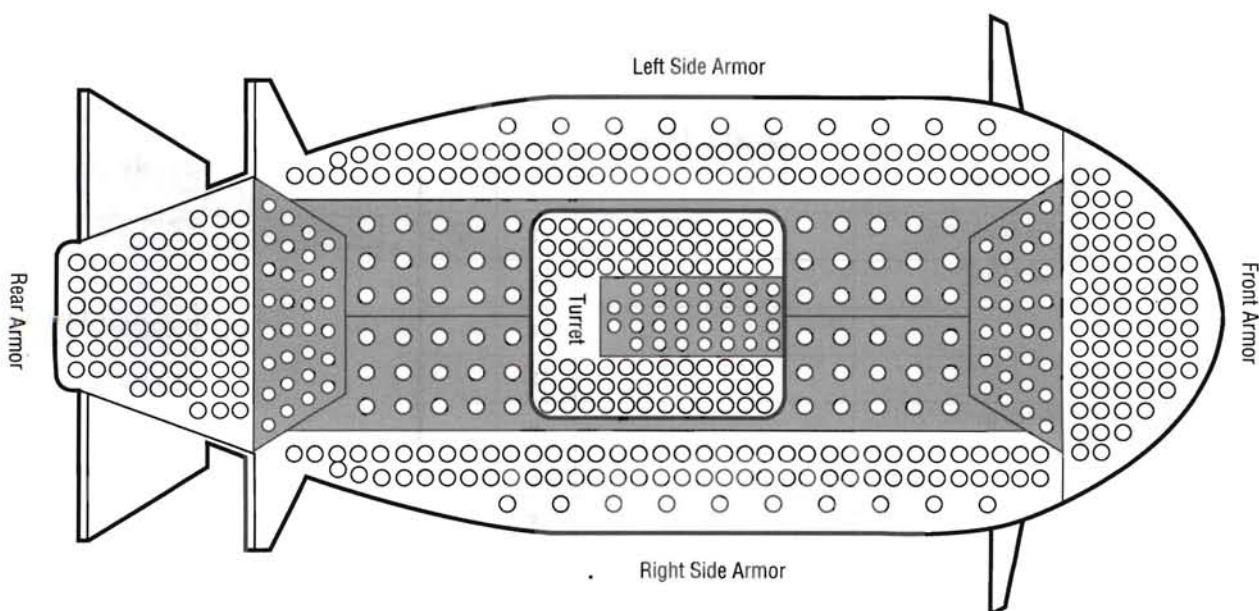

# Battle Armor Record Form

STAR NUMBER \_\_\_\_\_

**POINT NUMBER 1**

1	10	09	08	07	06	05	04	03	02	01	00
2	10	09	08	07	06	05	04	03	02	01	00
3	10	09	08	07	06	05	04	03	02	01	00
4	10	09	08	07	06	05	04	03	02	01	00
5	10	09	08	07	06	05	04	03	02	01	00

WEAPON TYPE \_\_\_\_\_  
 MISSILE SALVO 1       MISSILE SALVO 2

STAR NUMBER \_\_\_\_\_

**POINT NUMBER 1**

1	10	09	08	07	06	05	04	03	02	01	00
2	10	09	08	07	06	05	04	03	02	01	00
3	10	09	08	07	06	05	04	03	02	01	00
4	10	09	08	07	06	05	04	03	02	01	00
5	10	09	08	07	06	05	04	03	02	01	00

WEAPON TYPE \_\_\_\_\_  
 MISSILE SALVO 1       MISSILE SALVO 2

**POINT NUMBER 2**

1	10	09	08	07	06	05	04	03	02	01	00
2	10	09	08	07	06	05	04	03	02	01	00
3	10	09	08	07	06	05	04	03	02	01	00
4	10	09	08	07	06	05	04	03	02	01	00
5	10	09	08	07	06	05	04	03	02	01	00

WEAPON TYPE \_\_\_\_\_  
 MISSILE SALVO 1       MISSILE SALVO 2

**POINT NUMBER 2**

1	10	09	08	07	06	05	04	03	02	01	00
2	10	09	08	07	06	05	04	03	02	01	00
3	10	09	08	07	06	05	04	03	02	01	00
4	10	09	08	07	06	05	04	03	02	01	00
5	10	09	08	07	06	05	04	03	02	01	00

WEAPON TYPE \_\_\_\_\_  
 MISSILE SALVO 1       MISSILE SALVO 2

**POINT NUMBER 3**

1	10	09	08	07	06	05	04	03	02	01	00
2	10	09	08	07	06	05	04	03	02	01	00
3	10	09	08	07	06	05	04	03	02	01	00
4	10	09	08	07	06	05	04	03	02	01	00
5	10	09	08	07	06	05	04	03	02	01	00

WEAPON TYPE \_\_\_\_\_  
 MISSILE SALVO 1       MISSILE SALVO 2

**POINT NUMBER 3**

1	10	09	08	07	06	05	04	03	02	01	00
2	10	09	08	07	06	05	04	03	02	01	00
3	10	09	08	07	06	05	04	03	02	01	00
4	10	09	08	07	06	05	04	03	02	01	00
5	10	09	08	07	06	05	04	03	02	01	00

WEAPON TYPE \_\_\_\_\_  
 MISSILE SALVO 1       MISSILE SALVO 2

**POINT NUMBER 4**

1	10	09	08	07	06	05	04	03	02	01	00
2	10	09	08	07	06	05	04	03	02	01	00
3	10	09	08	07	06	05	04	03	02	01	00
4	10	09	08	07	06	05	04	03	02	01	00
5	10	09	08	07	06	05	04	03	02	01	00

WEAPON TYPE \_\_\_\_\_  
 MISSILE SALVO 1       MISSILE SALVO 2

**POINT NUMBER 4**

1	10	09	08	07	06	05	04	03	02	01	00
2	10	09	08	07	06	05	04	03	02	01	00
3	10	09	08	07	06	05	04	03	02	01	00
4	10	09	08	07	06	05	04	03	02	01	00
5	10	09	08	07	06	05	04	03	02	01	00

WEAPON TYPE \_\_\_\_\_  
 MISSILE SALVO 1       MISSILE SALVO 2

**POINT NUMBER 5**

1	10	09	08	07	06	05	04	03	02	01	00
2	10	09	08	07	06	05	04	03	02	01	00
3	10	09	08	07	06	05	04	03	02	01	00
4	10	09	08	07	06	05	04	03	02	01	00
5	10	09	08	07	06	05	04	03	02	01	00

WEAPON TYPE \_\_\_\_\_  
 MISSILE SALVO 1       MISSILE SALVO 2

**POINT NUMBER 5**

1	10	09	08	07	06	05	04	03	02	01	00
2	10	09	08	07	06	05	04	03	02	01	00
3	10	09	08	07	06	05	04	03	02	01	00
4	10	09	08	07	06	05	04	03	02	01	00
5	10	09	08	07	06	05	04	03	02	01	00

WEAPON TYPE \_\_\_\_\_  
 MISSILE SALVO 1       MISSILE SALVO 2

## BATTLE ARMOR MISSILES TABLE

Die Roll (2D6)	Members Active (Number of Missiles Fired)				
	1 (2)	2 (4)	3 (6)	4 (8)	5 (10)
2	1	1	2	2	3
3	1	2	2	3	3
4	1	2	3	3	4
5	1	2	3	4	6
6	1	2	4	4	6
7	1	3	4	5	6
8	2	3	4	5	6
9	2	3	5	6	8
10	2	3	5	7	8
11	2	4	6	8	10
12	2	4	6	8	10

## BATTLE ARMOR DIRECT FIRE TABLE

Die Roll (2D6)	Point Members Active				
	1	2	3	4	5
2	1	1	1	1	1
3	1	1	1	2	2
4	1	1	2	2	2
5	1	1	2	2	3
6	1	1	2	2	3
7	1	2	2	3	3
8	1	2	2	3	4
9	1	2	3	3	4
10	1	2	3	4	4
11	1	2	3	4	5
12	1	2	3	4	5

## LEG ATTACKS TABLE

Battle Armored Troopers Active	Base To-Hit Number
4-5	4
3	7
2	10
1	12
—	No attack possible

## SWARM ATTACKS TABLE

Battle Armored Troopers Active	Base To-Hit Number
4-5	7
1-3	10
—	No attack possible

## SWARM HIT LOCATION TABLE

Die Roll (2D6)	Location	Die Roll (2D6)	Location
2	Head	7	Front Center Torso
3	Rear Center Torso	8	Left Arm
4	Rear Right Torso	9	Front Left Torso
5	Front Right Torso	10	Rear Left Torso
6	Right Arm	11	Rear Center Torso
		12	Head

# BATTLETECH®

## INFANTRY RECORD SHEET

▼ Jump Platoons Start Here

	28	27	26	25	24	23	22	21	20	19	18	17	16	15	14	13	12	11	10	9	8	7	6	5	4	3	2	1
Rifle Platoon	7	7	7	7	6	6	6	6	5	5	5	5	4	4	4	4	3	3	3	3	2	2	2	2	1	1	1	1
Machine Gun or Flamer Platoon	10	9	9	8	8	8	7	7	7	6	6	6	5	5	5	4	4	4	3	3	3	2	2	2	1	1	1	1
Laser or SRM Platoon	14	14	13	13	12	12	11	11	10	10	9	9	8	8	7	7	6	6	5	5	4	4	3	3	2	2	1	1

▼ Jump Platoons Start Here

	28	27	26	25	24	23	22	21	20	19	18	17	16	15	14	13	12	11	10	9	8	7	6	5	4	3	2	1
Rifle Platoon	7	7	7	7	6	6	6	6	5	5	5	5	4	4	4	4	3	3	3	3	2	2	2	2	1	1	1	1
Machine Gun or Flamer Platoon	10	9	9	8	8	8	7	7	7	6	6	6	5	5	5	4	4	4	3	3	3	2	2	2	1	1	1	1
Laser or SRM Platoon	14	14	13	13	12	12	11	11	10	10	9	9	8	8	7	7	6	6	5	5	4	4	3	3	2	2	1	1

▼ Jump Platoons Start Here

	28	27	26	25	24	23	22	21	20	19	18	17	16	15	14	13	12	11	10	9	8	7	6	5	4	3	2	1
Rifle Platoon	7	7	7	7	6	6	6	6	5	5	5	5	4	4	4	4	3	3	3	3	2	2	2	2	1	1	1	1
Machine Gun or Flamer Platoon	10	9	9	8	8	8	7	7	7	6	6	6	5	5	5	4	4	4	3	3	3	2	2	2	1	1	1	1
Laser or SRM Platoon	14	14	13	13	12	12	11	11	10	10	9	9	8	8	7	7	6	6	5	5	4	4	3	3	2	2	1	1

▼ Jump Platoons Start Here

	28	27	26	25	24	23	22	21	20	19	18	17	16	15	14	13	12	11	10	9	8	7	6	5	4	3	2	1
Rifle Platoon	7	7	7	7	6	6	6	6	5	5	5	5	4	4	4	4	3	3	3	3	2	2	2	2	1	1	1	1
Machine Gun or Flamer Platoon	10	9	9	8	8	8	7	7	7	6	6	6	5	5	5	4	4	4	3	3	3	2	2	2	1	1	1	1
Laser or SRM Platoon	14	14	13	13	12	12	11	11	10	10	9	9	8	8	7	7	6	6	5	5	4	4	3	3	2	2	1	1

▼ Jump Platoons Start Here

	28	27	26	25	24	23	22	21	20	19	18	17	16	15	14	13	12	11	10	9	8	7	6	5	4	3	2	1
Rifle Platoon	7	7	7	7	6	6	6	6	5	5	5	5	4	4	4	4	3	3	3	3	2	2	2	2	1	1	1	1
Machine Gun or Flamer Platoon	10	9	9	8	8	8	7	7	7	6	6	6	5	5	5	4	4	4	3	3	3	2	2	2	1	1	1	1
Laser or SRM Platoon	14	14	13	13	12	12	11	11	10	10	9	9	8	8	7	7	6	6	5	5	4	4	3	3	2	2	1	1

### LEG ATTACKS TABLE

Men in Platoon	Base To-Hit Number
28-22	4
21-16	7
15-10	10
9-5	12
4-1	No attack possible

### SWARM ATTACKS TABLE

Men in Platoon	Base To-Hit Number
28-22	7
21-16	10
15-1	No attack possible

### SWARM HIT LOCATION TABLE

Die Roll (2D6)	Location
2	Head
3	Rear Center Torso
4	Rear Rt Torso
5	Front Rt Torso
6	Rt Arm
7	Front Center Torso
8	Lt Arm
9	Front Lt Torso
10	Rear Lt Torso
11	Rear Center Torso
12	Head

### BASE TO-HIT NUMBER TABLE

Weapon Type	Range in Hexes					
	0	1	2	3	4	5 6
Rifle	2	4	6	-	-	-
Machine Gun	2	4	6	8	-	-
Flamer	3	4	6	-	-	-
Portable Laser	2	4	6	8	-	-
SRM Missiles	3	4	4	6	6	8 8

# BATTLETECH®

## BATTLEMECH RECORD SHEET

### ARMOR DIAGRAM

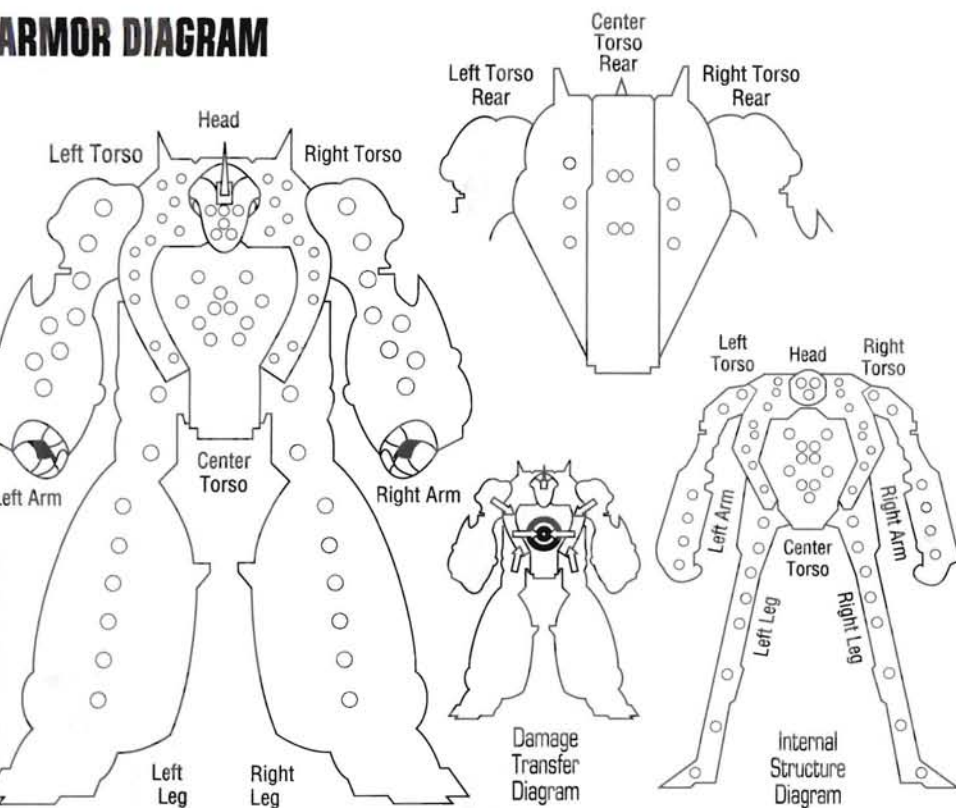

### Mech Data

Type: **RVN-3L RAVEN**      Tonnage: **35**  
 Movement Points:  
 Walking: **6**      Technology Base:  
 Running: **9**      Inner Sphere  
 Jumping: **0**

---

### Weapons Inventory

Type	Location	Heat	Damage	Min.	Short	Med.	Long
SRM-6	RT	4	2/Hit	-	3	6	9
Med. Laser	RA	3	5	-	3	6	9
Med. Laser							
Narc Beacon	LA	0	-	-	3	6	9
Beagle Probe	CT	-	-	-	-	-	4
Guardian ECM	LT	-	-	-	-	-	6
TAG	RT	-	-	-	5	9	15

---

**Total Heat Sinks: 11**

○ ○ ○ ○ ○ ○ ○ ○ ○ ○ ○      Single

---

### Auto Eject

Operational       Disabled

### Warrior Data

Name: \_\_\_\_\_  
 Gunnery Skill: \_\_\_\_\_      Piloting Skill: \_\_\_\_\_

Hits Taken	1	2	3	4	5	6
Consciousness #	3	5	7	10	11	Dead

### Heat Scale

30	Shutdown
29	
28	Ammo Explosion, avoid on 8+
27	
26	Shutdown, avoid on 10+
25	-5 Movement Points
24	+4 Modifier to Fire
23	Ammo Explosion, avoid on 6+
22	Shutdown, avoid on 8+
21	
20	-4 Movement Points
19	Ammo Explosion, avoid on 4+
18	Shutdown, avoid on 6+
17	+3 Modifier to Fire
16	
15	-3 Movement Points
14	Shutdown, avoid on 4+
13	+2 Modifier to Fire
12	
11	
10	-2 Movement Points
09	
08	+1 Modifier to Fire
07	
06	
05	-1 Movement Points
04	
03	
02	
01	
00	

### Critical Hit Table

#### Left Arm

- Shoulder
- Upper Arm Actuator
- Lower Arm Actuator

**1-3**

- Narc Beacon
- Narc Beacon
- Ferro-Fibrous

**4-6**

- Ferro-Fibrous
- Ferro-Fibrous
- Ferro-Fibrous
- Ferro-Fibrous
- Ferro-Fibrous
- Ferro-Fibrous

#### Left Torso

- Ammo (SRM-6) 15
- CASE

**1-3**

- Guardian ECM
- Guardian ECM
- Ammo (Narc) 6
- Ammo (Narc) 6

**4-6**

- Engine
- Engine
- Engine
- Roll Again
- Roll Again
- Roll Again

#### Left Leg

- Hip
- Upper Leg Actuator
- Lower Leg Actuator
- Foot Actuator
- Heat Sink
- Roll Again

#### Head

- Life Support
- Sensors
- Cockpit
- Heat Sink
- Life Support
- Life Support

#### Center Torso

- Engine
- Engine
- Engine

**1-3**

- Gyro
- Gyro
- Gyro

**4-6**

- Engine
- Engine
- Engine
- Beagle Probe
- Beagle Probe
- Beagle Probe

#### Right Arm

- Shoulder
- Upper Arm Actuator
- Lower Arm Actuator

**1-3**

- Med. Laser
- Med. Laser
- Ferro-Fibrous

**4-6**

- Ferro-Fibrous
- Ferro-Fibrous
- Ferro-Fibrous
- Ferro-Fibrous
- Ferro-Fibrous
- Ferro-Fibrous

#### Right Torso

- SRM-6
- SRM-6

**1-3**

- TAG
- Engine
- Engine
- Engine
- Engine
- Engine

**4-6**

- Roll Again
- Roll Again
- Roll Again
- Roll Again
- Roll Again
- Roll Again

#### Right Leg

- Hip
- Upper Leg Actuator
- Lower Leg Actuator
- Foot Actuator
- Heat Sink
- Roll Again

Engine Hits	○ ○ ○
Gyro Hits	○ ○
Sensor Hits	○ ○
Life Support	○

Combat Value **1777**  
 Cost **5,692,950**

# BATTLETECH®

## BATTLEMECH RECORD SHEET

### ARMOR DIAGRAM

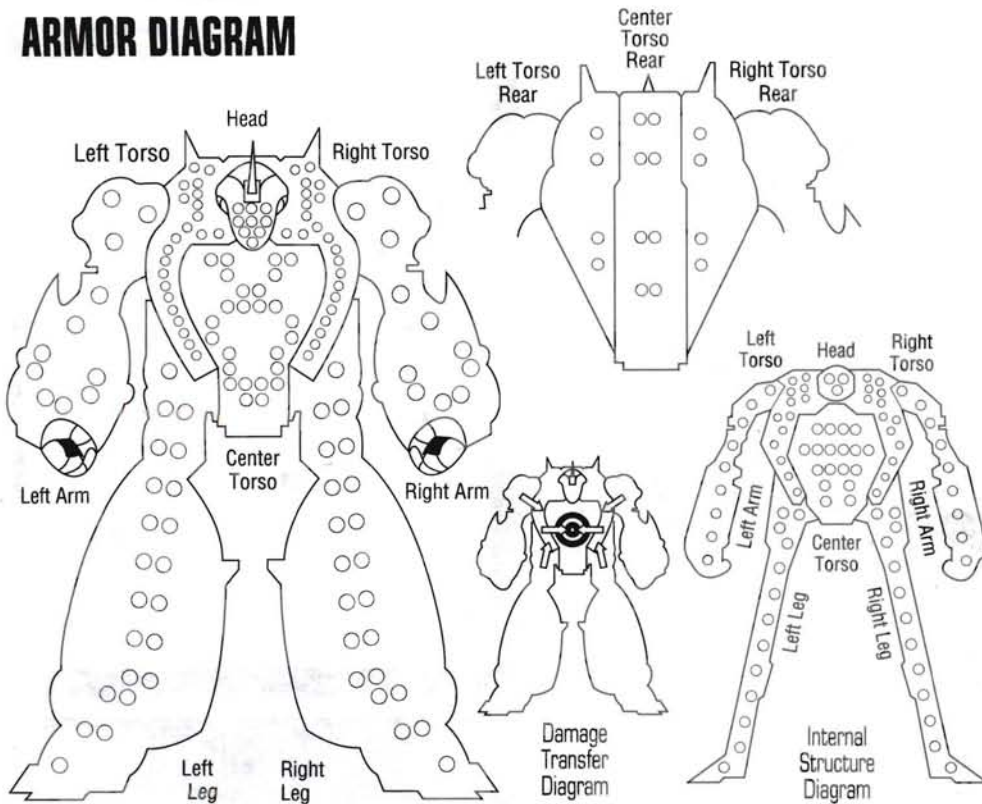

### Mech Data

Type: **BSW-X1 BUSHWACKER** Tonnage: **55**  
 Movement Points:  
 Walking: **5** Technology Base:  
 Running: **8** Inner Sphere  
 Jumping: **0**

### Weapons Inventory

Type	Location	Heat	Damage	Min.	Short	Med.	Long
AC/10	RA	3	10	-	5	10	15
LRM 5	LA	2	1/Hit	6	7	14	21
LRM 5	LT						
ER Lg. Laser	CT	12	8	-	7	14	19
Machine Gun	RT	0	2	-	1	2	3
Machine Gun	LT						

**Total Heat Sinks: 11 (22)**

○○○○○○○○○○ Double

### Auto Eject

Operational  Disabled

### Warrior Data

Name: \_\_\_\_\_  
 Gunnery Skill: \_\_\_\_\_ Piloting Skill: \_\_\_\_\_  
 Hits Taken 

1	2	3	4	5	6
---	---	---	---	---	---

  
 Consciousness # 

3	5	7	10	11	Dead
---	---	---	----	----	------

### Heat Scale

30	Shutdown
29	
28	Ammo Explosion, avoid on 8+
27	
26	Shutdown, avoid on 10+
25	-5 Movement Points
24	+4 Modifier to Fire
23	Ammo Explosion, avoid on 6+
22	Shutdown, avoid on 8+
21	
20	-4 Movement Points
19	Ammo Explosion, avoid on 4+
18	Shutdown, avoid on 6+
17	+3 Modifier to Fire
16	
15	-3 Movement Points
14	Shutdown, avoid on 4+
13	+2 Modifier to Fire
12	
11	
10	-2 Movement Points
09	
08	+1 Modifier to Fire
07	
06	
05	-1 Movement Points
04	
03	
02	
01	
00	

### Critical Hit Table

#### Left Arm

- Shoulder
  - Upper Arm Actuator
  - Lower Arm Actuator
  - LRM 5
  - Ferro-Fibrous
  - Ferro-Fibrous
- 1-3**
- Ferro-Fibrous
  - Ferro-Fibrous
  - Ferro-Fibrous
  - Ferro-Fibrous
  - Roll Again
  - Roll Again
- 4-6**

#### Head

- Life Support
- Sensors
- Cockpit
- Roll Again
- Sensors
- Life Support

#### Center Torso

- Engine
  - Engine
  - Engine
  - Gyro
  - Gyro
  - Gyro
- 1-3**
- Gyro
  - Engine
  - Engine
  - Engine
  - ER Lg. Laser
  - ER Lg. Laser
- 4-6**

#### Left Torso

- Engine
  - Engine
  - Engine
  - Machine Gun
  - LRM 5
  - Roll Again
- 1-3**
- Ammo (LRM 5) 24
  - CASE
  - Ferro-Fibrous
  - Ferro-Fibrous
  - Ferro-Fibrous
  - Ferro-Fibrous
- 4-6**

#### Left Leg

- Hip
- Upper Leg Actuator
- Lower Leg Actuator
- Foot Actuator
- Roll Again
- Roll Again

Engine Hits ○○○○  
 Gyro Hits ○○○○  
 Sensor Hits ○○○○  
 Life Support ○

Combat Value **3251**  
 Cost **9,822,712**

#### Right Arm

- Shoulder
  - Upper Arm Actuator
  - Lower Arm Actuator
  - Hand Actuator
  - Ferro-Fibrous
  - AC/10
- 1-3**
- AC/10
  - AC/10
  - AC/10
  - AC/10
  - AC/10
  - AC/10
- 4-6**

#### Right Torso

- Engine
  - Engine
  - Engine
  - Machine Gun
  - Roll Again
  - Roll Again
- 1-3**
- Ammo (MG) 100
  - Ammo (AC/10) 100
  - CASE
  - Ferro-Fibrous
  - Ferro-Fibrous
  - Ferro-Fibrous
- 4-6**

#### Right Leg

- Hip
- Upper Leg Actuator
- Lower Leg Actuator
- Foot Actuator
- Roll Again
- Roll Again

# BATTLETECH®

## BATTLEMECH RECORD SHEET

### ARMOR DIAGRAM

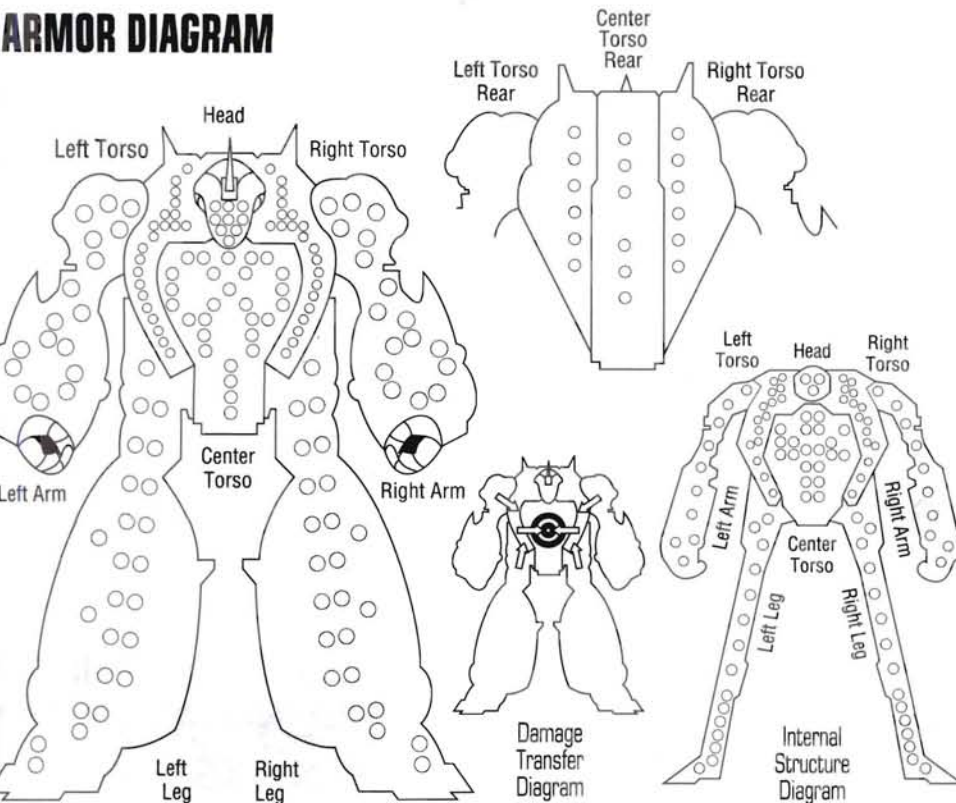

#### Left Arm

- Shoulder
- Upper Arm Actuator
- Lower Arm Actuator
- Hand Actuator
- Lg. Pulse Laser
- Lg. Pulse Laser

1-3

- Ferro-Fibrous
- Ferro-Fibrous
- Ferro-Fibrous
- Ferro-Fibrous
- Ferro-Fibrous
- Ferro-Fibrous

4-6

#### Left Torso

- LRM 15
- LRM 15
- LRM 15
- Ammo (LRM 15) 8
- Ammo (LRM 15) 8
- CASE

1-3

- Engine
- Engine
- Engine
- Ferro-Fibrous
- Ferro-Fibrous
- Ferro-Fibrous

4-6

#### Left Leg

- Hip
- Upper Leg Actuator
- Lower Leg Actuator
- Foot Actuator
- Jump Jet
- Jump Jet

### Critical Hit Table

#### Head

- Life Support
- Sensors
- Cockpit
- Roll Again
- Sensors
- Life Support

#### Center Torso

- Engine
- Engine
- Engine
- Gyro
- Gyro
- Gyro

1-3

- Gyro
- Engine
- Engine
- Engine
- Roll Again
- Roll Again

4-6



Combat Value **4094**  
Cost **11,989,010**

#### Right Arm

- Shoulder
- Upper Arm Actuator
- Lower Arm Actuator
- Hand Actuator
- Med. Laser
- Med. Laser

1-3

- Med. Laser
- Hatchet
- Hatchet
- Hatchet
- Hatchet
- Hatchet

4-6

#### Right Torso

- LRM 15
- LRM 15
- LRM 15
- Engine
- Engine
- Engine

1-3

- Ferro-Fibrous
- Ferro-Fibrous
- Ferro-Fibrous
- Ferro-Fibrous
- Ferro-Fibrous
- Roll Again

4-6

#### Right Leg

- Hip
- Upper Leg Actuator
- Lower Leg Actuator
- Foot Actuator
- Jump Jet
- Jump Jet

### Mech Data

Type: **AXM-2N AXMAN** Tonnage: **65**  
 Movement Points:  
 Walking: **4** Technology Base:  
 Running: **6** Inner Sphere  
 Jumping: **4**

### Weapons Inventory

Type	Location	Heat	Damage	Min.	Short	Med.	Long
Lg. Pulse Laser	LA	10	9	-	3	7	10
LRM 15	RT	5	1/Hit	6	7	14	21
LRM 15	LT						
Hatchet	RA	0	13	-	-	-	-
Med. Laser	RA	3	5	-	3	6	9
Med. Laser							
Med. Laser							

Total Heat Sinks: **10 (20)**

○○○○○○○○○○ Double

### Auto Eject

Operational  Disabled

### Warrior Data

Name: \_\_\_\_\_

Gunnery Skill: \_\_\_\_\_ Piloting Skill: \_\_\_\_\_

Hits Taken	1	2	3	4	5	6
Consciousness #	3	5	7	10	11	Dead

### Heat Scale

30	Shutdown
29	
28	Ammo Explosion, avoid on 8+
27	
26	Shutdown, avoid on 10+
25	-5 Movement Points
24	+4 Modifier to Fire
23	Ammo Explosion, avoid on 6+
22	Shutdown, avoid on 8+
21	
20	-4 Movement Points
19	Ammo Explosion, avoid on 4+
18	Shutdown, avoid on 6+
17	+3 Modifier to Fire
16	
15	-3 Movement Points
14	Shutdown, avoid on 4+
13	+2 Modifier to fire
12	
11	
10	-2 Movement Points
09	
08	+1 Modifier to Fire
07	
06	
05	
04	
03	
02	
01	
00	-1 Movement Points

# BATTLETECH®

## BATTLEMECH RECORD SHEET

### ARMOR DIAGRAM

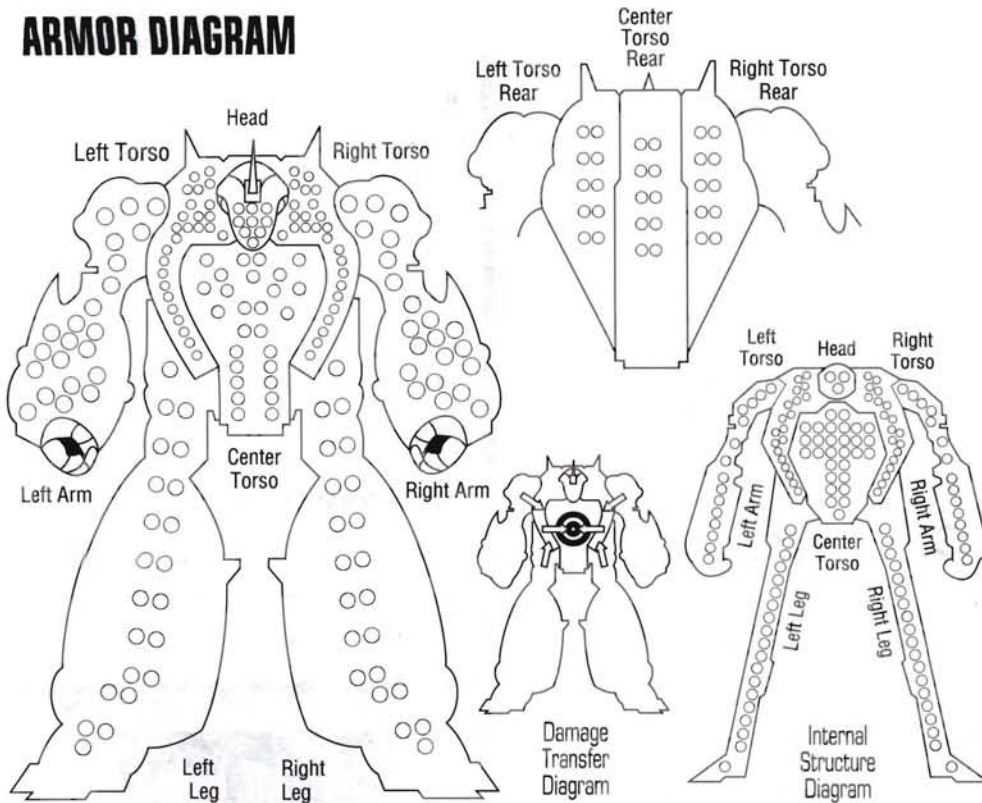

### Mech Data

Type: **MAL-1R MAULER**      Tonnage: **90**  
 Movement Points:  
 Walking: **3**      Technology Base:  
 Running: **5**      Inner Sphere  
 Jumping: **0**

### Weapons Inventory

Type	Location	Heat	Damage	Min.	Short	Med.	Long
ER Lg. Laser	RA	12	8	-	7	14	19
ER Lg. Laser	LA						
LRM 15	RT	5	1/Hit	6	7	14	21
LRM 15	LT						
AC/2	RT	1	2	4	8	16	24
AC/2	RT						
AC/2	LT						
AC/2	LT						

**Total Heat Sinks: 11 (22)**

○○○○○○○○○○ Double

### Auto Eject

Operational       Disabled

### Warrior Data

Name: \_\_\_\_\_  
 Gunnery Skill: \_\_\_\_\_ Piloting Skill: \_\_\_\_\_  
 Hits Taken

1	2	3	4	5	6
---	---	---	---	---	---

Consciousness #

3	5	7	10	11	Dead
---	---	---	----	----	------

### Heat Scale

30	Shutdown
29	
28	Ammo Explosion, avoid on 8+
27	
26	Shutdown, avoid on 10+
25	-5 Movement Points
24	+4 Modifier to Fire
23	Ammo Explosion, avoid on 6+
22	Shutdown, avoid on 8+
21	
20	-4 Movement Points
19	Ammo Explosion, avoid on 4+
18	Shutdown, avoid on 6+
17	+3 Modifier to Fire
16	
15	-3 Movement Points
14	Shutdown, avoid on 4+
13	+2 Modifier to fire
12	
11	
10	-2 Movement Points
09	
08	+1 Modifier to Fire
07	
06	
05	-1 Movement Points
04	
03	
02	
01	
00	

### Critical Hit Table

#### Left Arm

- Shoulder
  - Upper Arm Actuator
  - Lower Arm Actuator
- 1-3**
- Ferro-Fibrous
  - ER Lg. Laser
  - ER Lg. Laser

**4-6**

- Double Heat Sink
- Double Heat Sink
- Double Heat Sink
- Ferro-Fibrous
- Ferro-Fibrous
- Ferro-Fibrous

#### Left Torso

- LRM 15
  - LRM 15
  - LRM 15
- 1-3**
- Ammo (LRM 15) 8
  - Ammo (LRM 15) 8
  - CASE

**4-6**

- AC/2
- AC/2
- Ammo (AC/2) 45
- Engine
- Engine
- Engine

#### Left Leg

- Hip
- Upper Leg Actuator
- Lower Leg Actuator
- Foot Actuator
- Roll Again
- Roll Again

#### Head

- Life Support
- Sensors
- Cockpit
- Ferro-Fibrous
- Sensors
- Life Support

#### Center Torso

**1-3**

- Engine
- Engine
- Engine
- Gyro
- Gyro
- Gyro

**4-6**

- Gyro
- Engine
- Engine
- Engine
- Ferro-Fibrous
- Ferro-Fibrous

Engine Hits ○○○○  
 Gyro Hits ○○○○  
 Sensor Hits ○○○○  
 Life Support ○

Combat Value **5010**  
 Cost **18,399,600**

#### Right Arm

- Shoulder
  - Upper Arm Actuator
  - Lower Arm Actuator
- 1-3**
- Ferro-Fibrous
  - ER Lg. Laser
  - ER Lg. Laser

**4-6**

- Ferro-Fibrous
- Ferro-Fibrous
- Ferro-Fibrous
- Ferro-Fibrous
- Ferro-Fibrous
- Ferro-Fibrous

#### Right Torso

- LRM 15
  - LRM 15
  - LRM 15
- 1-3**
- Ammo (LRM 15) 8
  - Ammo (LRM 15) 8
  - CASE

**4-6**

- AC/2
- AC/2
- Ammo (AC/2) 45
- Engine
- Engine
- Engine

#### Right Leg

- Hip
- Upper Leg Actuator
- Lower Leg Actuator
- Foot Actuator
- Roll Again
- Roll Again

# BATTLETECH®

## BATTLEMECH RECORD SHEET

### ARMOR DIAGRAM

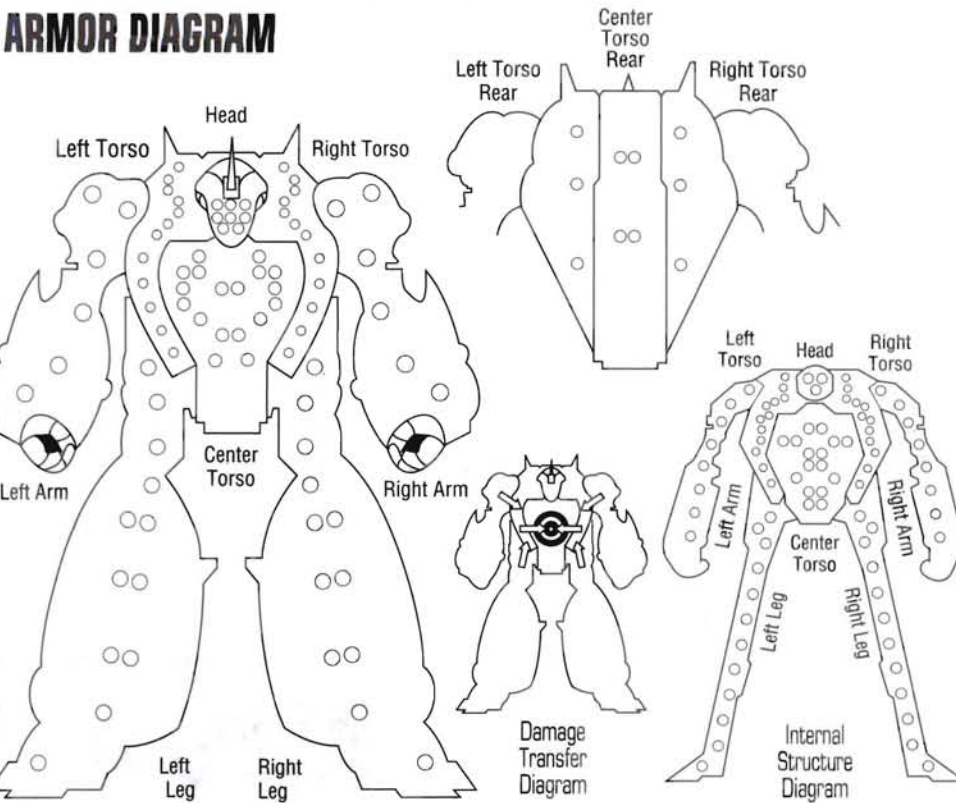

### Mech Data

Type: **HUNCHBACK IIC** Tonnage: **50**  
 Movement Points:  
 Walking: **4** Technology Base:  
 Running: **6** Clan  
 Jumping: **4**

### Weapons Inventory

Type	Location	Heat	Damage	Min.	Short	Med.	Long
Ultra AC/20	RT	7	20	-	4	8	12
Ultra AC/20	LT						
ER Med. Laser	CT	5	7	-	5	10	15
ER Med. Laser							

### Total Heat Sinks: 12 (24)

○ ○ ○ ○ ○ ○ ○ ○ ○ ○ ○ ○ Double

### Auto Eject

Operational  Disabled

### Warrior Data

Name: \_\_\_\_\_

Gunnery Skill: \_\_\_\_\_ Piloting Skill: \_\_\_\_\_

Hits Taken	1	2	3	4	5	6
Consciousness #	3	5	7	10	11	Dead

### Left Arm

### Critical Hit Table

### Right Arm

- 1-3**
- Shoulder
  - Upper Arm Actuator
  - Lower Arm Actuator
  - Hand Actuator
  - Double Heat Sink
  - Double Heat Sink
- 4-6**
- Double Heat Sink
  - Double Heat Sink
  - Endo Steel
  - Endo Steel
  - Endo Steel
  - Roll Again

### Head

- 1-3**
- Shoulder
  - Upper Arm Actuator
  - Lower Arm Actuator
  - Hand Actuator
  - Double Heat Sink
  - Double Heat Sink
- 4-6**
- Double Heat Sink
  - Double Heat Sink
  - Endo Steel
  - Endo Steel
  - Endo Steel
  - Roll Again

- Life Support
- Sensors
- Cockpit
- Endo Steel
- Sensors
- Life Support

### Center Torso

### Right Torso

### Left Torso

- 1-3**
- Ultra AC/20
  - Ultra AC/20
  - Ultra AC/20
  - Ultra AC/20
  - Ultra AC/20
  - Ultra AC/20
- 4-6**
- Ultra AC/20
  - Ultra AC/20
  - Ammo (Ultra AC/20) 5
  - Engine
  - Engine
  - Roll Again

- 1-3**
- Engine
  - Engine
  - Engine
  - Gyro
  - Gyro
  - Gyro
- 4-6**
- Gyro
  - Engine
  - Engine
  - Engine
  - ER Med. Laser
  - ER Med. Laser

- 1-3**
- Ultra AC/20
  - Ultra AC/20
  - Ultra AC/20
  - Ultra AC/20
  - Ultra AC/20
  - Ultra AC/20
- 4-6**
- Ultra AC/20
  - Ultra AC/20
  - Ammo (Ultra AC/20) 5
  - Engine
  - Engine
  - Roll Again

### Left Leg

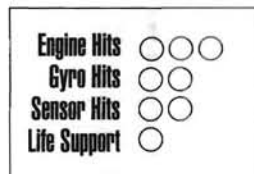

Combat Value **3822**  
 Cost **7,960,000**

### Right Leg

- Hip
- Upper Leg Actuator
- Lower Leg Actuator
- Foot Actuator
- Jump Jet
- Jump Jet

- Hip
- Upper Leg Actuator
- Lower Leg Actuator
- Foot Actuator
- Jump Jet
- Jump Jet

### Heat Scale

30	Shutdown
29	
28	Ammo Explosion, avoid on 8+
27	
26	Shutdown, avoid on 10+
25	-5 Movement Points
24	+4 Modifier to Fire
23	Ammo Explosion, avoid on 6+
22	Shutdown, avoid on 8+
21	
20	-4 Movement Points
19	Ammo Explosion, avoid on 4+
18	Shutdown, avoid on 6+
17	+3 Modifier to Fire
16	
15	-3 Movement Points
14	Shutdown, avoid on 4+
13	+2 Modifier to Fire
12	
11	
10	-2 Movement Points
09	
08	+1 Modifier to Fire
07	
06	
05	-1 Movement Points
04	
03	
02	
01	
00	

# BATTLETECH®

## BATTLEMECH RECORD SHEET

### ARMOR DIAGRAM

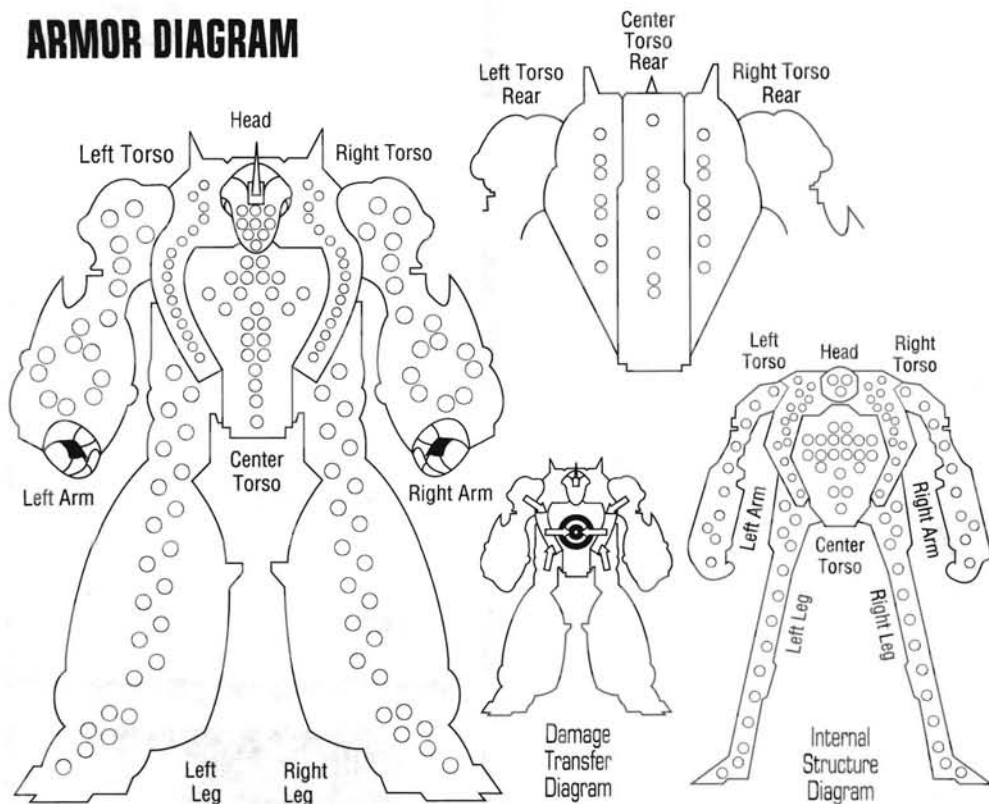

### Mech Data

Type: **VULTURE (Primary)** Tonnage: **60**  
 Movement Points:  
 Walking: **5** Technology Base:  
 Running: **8** Clan  
 Jumping: **0**

### Weapons Inventory

Type	Location	Heat	Damage	Min.	Short	Med.	Long
Lg. Pulse Laser	RA	10	10	-	6	14	20
Lg. Pulse Laser	LA						
Med. Pulse Laser	RA	4	7	-	4	8	12
Med. Pulse Laser	LA						
LRM 20	RT	6	1/Hit	-	7	14	21
LRM 20	LT						

### Total Heat Sinks: 12 (24)

○○○○○○○○○○○○ Double

### Auto Eject

Operational  Disabled

### Warrior Data

Name: \_\_\_\_\_  
 Gunnery Skill: \_\_\_\_\_ Piloting Skill: \_\_\_\_\_  
 Hits Taken

1	2	3	4	5	6
---	---	---	---	---	---

Consciousness #

3	5	7	10	11	Dead
---	---	---	----	----	------

### Heat Scale

30	Shutdown
29	
28	Ammo Explosion, avoid on 8+
27	
26	Shutdown, avoid on 10+
25	-5 Movement Points
24	+4 Modifier to Fire
23	Ammo Explosion, avoid on 6+
22	Shutdown, avoid on 8+
21	
20	-4 Movement Points
19	Ammo Explosion, avoid on 4+
18	Shutdown, avoid on 6+
17	+3 Modifier to Fire
16	
15	-3 Movement Points
14	Shutdown, avoid on 4+
13	+2 Modifier to fire
12	
11	
10	-2 Movement Points
09	
08	+1 Modifier to Fire
07	
06	
05	-1 Movement Points
04	
03	
02	
01	
00	

### Critical Hit Table

#### Left Arm

- Shoulder
- Upper Arm Actuator
- Lower Arm Actuator
- 1-3 Lg. Pulse Laser
- 5 Lg. Pulse Laser
- 6 Med. Pulse Laser

- 1-3 Ferro-Fibrous
- 2 Roll Again
- 4-6 Roll Again
- 3 Roll Again
- 4 Roll Again
- 5 Roll Again
- 6 Roll Again

#### Left Torso

- 1 LRM 20
- 2 LRM 20
- 3 LRM 20
- 4 LRM 20
- 1-3 5 Ammo (LRM 20) 6
- 6 Ferro-Fibrous

- 1 Engine
- 2 Engine
- 3-4 Ferro-Fibrous
- 4 Roll Again
- 5 Roll Again
- 6 Roll Again

#### Left Leg

- Hip
- Upper Leg Actuator
- Lower Leg Actuator
- Foot Actuator
- 5 Roll Again
- 6 Roll Again

#### Head

- 1 Life Support
- 2 Sensors
- 3 Cockpit
- 4 Ferro-Fibrous
- 5 Sensors
- 6 Life Support

#### Center Torso

- 1 Engine
- 2 Engine
- 3 Engine
- 1-3 4 Gyro
- 5 Gyro
- 6 Gyro

- 1 Gyro
- 2 Engine
- 3 Engine
- 4 Engine
- 4-6 5 Roll Again
- 6 Roll Again

Engine Hits ○○○○  
 Gyro Hits ○○○○  
 Sensor Hits ○○○○  
 Life Support ○

Combat Value **4130**  
 Cost **15,092,000**

#### Right Arm

- Shoulder
- Upper Arm Actuator
- Lower Arm Actuator
- 1-3 Lg. Pulse Laser
- 5 Lg. Pulse Laser
- 6 Med. Pulse Laser

- 1-3 Ferro-Fibrous
- 2 Roll Again
- 4-6 Roll Again
- 3 Roll Again
- 4 Roll Again
- 5 Roll Again
- 6 Roll Again

#### Right Torso

- 1 LRM 20
- 2 LRM 20
- 3 LRM 20
- 4 LRM 20
- 1-3 5 Ammo (LRM 20) 6
- 6 Ferro-Fibrous

- 1 Engine
- 2 Engine
- 3-4 Ferro-Fibrous
- 4 Roll Again
- 5 Roll Again
- 6 Roll Again

#### Right Leg

- Hip
- Upper Leg Actuator
- Lower Leg Actuator
- Foot Actuator
- 5 Roll Again
- 6 Roll Again

# BATTLETECH®

## BATTLEMECH RECORD SHEET

### ARMOR DIAGRAM

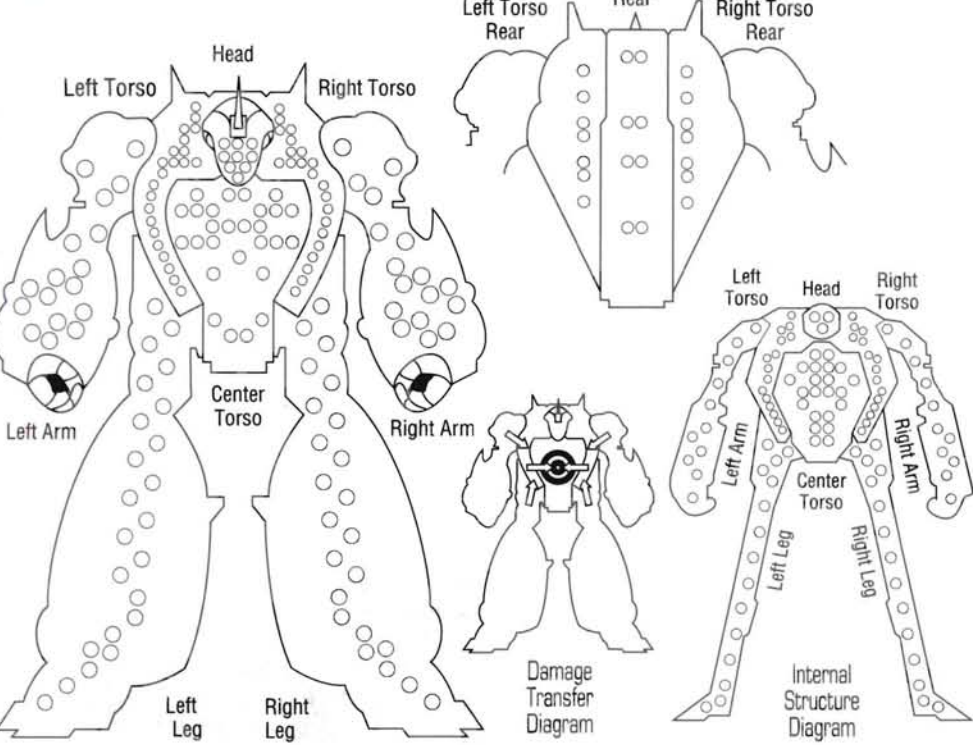

### Mech Data

Type: **THOR M**      Tonnage: **70**  
 Movement Points:  
 Walking: **5**      Technology Base:  
 Running: **8**      Clan  
 Jumping: **5**

### Weapons Inventory

Type	Location	Heat	Damage	Min.	Short	Med.	Long
LB10-X	LA	2	10	-	6	12	18
Streak SRM 6	LT	4	2/HIT	-	4	8	12
ER PPC	RA	15	15	-	7	14	23

**Total Heat Sinks: 14 (28)**

○○○○○○○○○○○○○○○○ Double

**Auto Eject**

Operational       Disabled

### Warrior Data

Name: \_\_\_\_\_  
 Gunnery Skill: \_\_\_\_\_ Piloting Skill: \_\_\_\_\_

Hits Taken	1	2	3	4	5	6
Consciousness #	3	5	7	10	11	Dead

### Heat Scale

30	Shutdown
29	
28	Ammo Explosion, avoid on 8+
27	
26	Shutdown, avoid on 10+
25	-5 Movement Points
24	+4 Modifier to Fire
23	Ammo Explosion, avoid on 6+
22	Shutdown, avoid on 8+
21	
20	-4 Movement Points
19	Ammo Explosion, avoid on 4+
18	Shutdown, avoid on 6+
17	+3 Modifier to Fire
16	
15	-3 Movement Points
14	Shutdown, avoid on 4+
13	+2 Modifier to fire
12	
11	
10	-2 Movement Points
09	
08	+1 Modifier to Fire
07	
06	
05	-1 Movement Points
04	
03	
02	
01	
00	

### Critical Hit Table

#### Left Arm

- Shoulder
- Upper Arm Actuator
- Lower Arm Actuator

**1-3**

- Ammo (LB 10-X) 10
- Ferro-Fibrous
- Roll Again

**4-6**

- LB 10-X
- LB 10-X
- LB 10-X
- LB 10-X
- LB 10-X
- Roll Again

#### Left Torso

- Streak SRM 6
- Streak SRM 6
- Ferro-Fibrous
- Engine
- Engine
- Ferro-Fibrous

**1-3**

- Roll Again
- Roll Again
- Roll Again
- Roll Again
- Roll Again
- Roll Again

**4-6**

#### Left Leg

- Hip
- Upper Leg Actuator
- Lower Leg Actuator
- Foot Actuator
- Jump Jet
- Jump Jet

#### Head

- Life Support
- Sensors
- Cockpit
- Ferro-Fibrous
- Sensors
- Life Support

#### Center Torso

- Engine
- Engine
- Engine
- Gyro
- Gyro
- Gyro

**1-3**

- Gyro
- Engine
- Engine
- Engine
- Jump Jet
- Roll Again

**4-6**

#### Right Arm

- Shoulder
- Upper Arm Actuator
- Lower Arm Actuator
- ER PPC
- ER PPC
- Ferro-Fibrous

**1-3**

- Roll Again
- Roll Again
- Roll Again
- Roll Again
- Roll Again
- Roll Again

**4-6**

#### Right Torso

- Engine
- Engine
- Ferro-Fibrous
- Ferro-Fibrous
- Ammo (Streak SRM 6) 15
- Ammo (Streak SRM 6) 15

**1-3**

- Roll Again
- Roll Again
- Roll Again
- Roll Again
- Roll Again
- Roll Again

**4-6**

#### Right Leg

- Hip
- Upper Leg Actuator
- Lower Leg Actuator
- Foot Actuator
- Jump Jet
- Jump Jet

Engine Hits	○○○
Gyro Hits	○○○
Sensor Hits	○○○
Life Support	○

Combat Value **4844**  
 Cost **21,091,333**

# BATTLETECH®

## BATTLEMECH RECORD SHEET

### ARMOR DIAGRAM

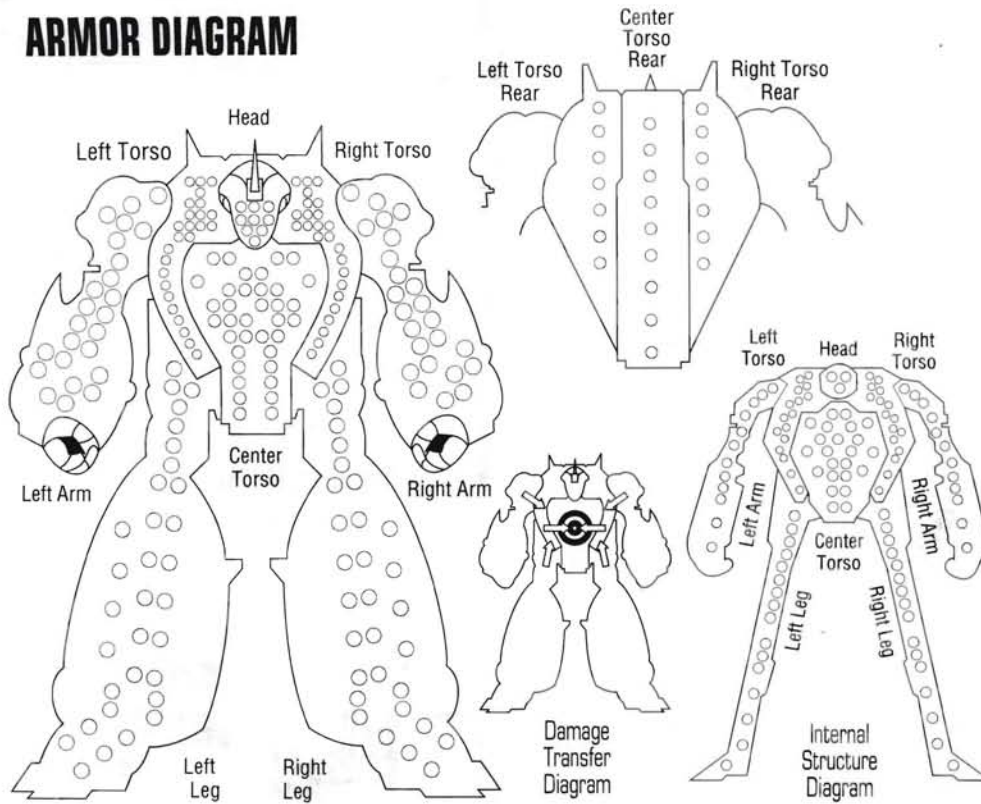

### Mech Data

Type: **MAD CAT (Primary)** Tonnage: **75**  
 Movement Points:  
 Walking: **5** Technology Base:  
 Running: **8** Clan  
 Jumping: **0**

### Weapons Inventory

Type	Location	Heat	Damage	Min.	Short	Med.	Long
Machine Gun	CT	0	2	-	1	2	3
Machine Gun	RT						
ER Lg. Laser	LA	12	10	-	8	15	25
ER Lg. Laser	RA						
ER Md. Laser	LA	5	7	-	5	10	15
ER Md. Laser	RA						
Md. Pulse Laser	LT	4	7	-	4	8	12
LRM 20	LT	6	1/Hit	-	7	14	21
LRM 20	RT						

Total Heat Sinks: **17 (34)**

○ Double

### Auto Eject

Operational  Disabled

### Warrior Data

Name: \_\_\_\_\_  
 Gunnery Skill: \_\_\_\_\_ Piloting Skill: \_\_\_\_\_  
 Hits Taken 

1	2	3	4	5	6
---	---	---	---	---	---

  
 Consciousness # 

3	5	7	10	11	Dead
---	---	---	----	----	------

### Heat Scale

30	Shutdown
29	
28	Ammo Explosion, avoid on 8+
27	
26	Shutdown, avoid on 10+
25	-5 Movement Points
24	+4 Modifier to Fire
23	Ammo Explosion, avoid on 6+
22	Shutdown, avoid on 8+
21	
20	-4 Movement Points
19	Ammo Explosion, avoid on 4+
18	Shutdown, avoid on 6+
17	+3 Modifier to Fire
16	
15	-3 Movement Points
14	Shutdown, avoid on 4+
13	+2 Modifier to fire
12	
11	
10	-2 Movement Points
09	
08	+1 Modifier to Fire
07	
06	
05	-1 Movement Points
04	
03	
02	
01	
00	

### Left Arm

- Shoulder
  - Upper Arm Actuator
  - Lower Arm Actuator
  - ER Lg. Laser
  - Double Heat Sink
  - Double Heat Sink
- 1-3**
- ER Md. Laser
  - Ferro-Fibrous
  - Roll Again
  - Roll Again
  - Roll Again
  - Roll Again
- 4-6**

### Left Torso

- Md. Pulse Laser
  - LRM 20
  - LRM 20
  - LRM 20
  - LRM 20
  - Ammo (LRM 20) 6
- 1-3**
- Engine
  - Engine
  - Ferro-Fibrous
  - Ferro-Fibrous
  - Endo Steel
  - Roll Again
- 4-6**

### Left Leg

- Hip
- Upper Leg Actuator
- Lower Leg Actuator
- Foot Actuator
- Endo Steel
- Endo Steel

### Critical Hit Table

#### Head

- Life Support
- Sensors
- Cockpit
- Ferro-Fibrous
- Sensors
- Life Support

#### Center Torso

- Engine
  - Engine
  - Engine
  - Gyro
  - Gyro
  - Gyro
- 1-3**
- Gyro
  - Engine
  - Engine
  - Engine
  - Machine Gun
  - Endo Steel
- 4-6**

Engine Hits ○ ○ ○  
 Gyro Hits ○ ○ ○  
 Sensor Hits ○ ○ ○  
 Life Support ○

Combat Value **5557**  
 Cost **24,012,734**

### Right Arm

- Shoulder
  - Upper Arm Actuator
  - Lower Arm Actuator
  - ER Lg. Laser
  - Double Heat Sink
  - Double Heat Sink
- 1-3**
- ER Md. Laser
  - Ferro-Fibrous
  - Roll Again
  - Roll Again
  - Roll Again
  - Roll Again
- 4-6**

### Right Torso

- Machine Gun
  - Ammo (MG) 200
  - LRM 20
  - LRM 20
  - LRM 20
  - LRM 20
- 1-3**
- Ammo (LRM 20) 6
  - Engine
  - Engine
  - Ferro-Fibrous
  - Ferro-Fibrous
  - Endo Steel
- 4-6**

### Right Leg

- Hip
- Upper Leg Actuator
- Lower Leg Actuator
- Foot Actuator
- Endo Steel
- Endo Steel

## INNER SPHERE WEAPONS & EQUIPMENT TABLE

Type	Heat	Dam.	Range					Tons	Crit.	Ammo
			Min.	Short	Med.	Long				
<i>Energy Weapons</i>										
ER Large Laser	12	8	—	1-7	8-14	15-19	5	2	—	
ER PPC	15	10	—	1-7	8-14	15-23	7	3	—	
Flamer	3	2	—	1	2	3	1	1	—	
Large Laser	8	8	—	1-5	6-10	11-15	5	2	—	
Medium Laser	3	5	—	1-3	4-6	7-9	1	1	—	
Small Laser	1	3	—	1	2	3	.5	1	—	
PPC	10	10	3	1-6	7-12	13-18	7	3	—	
Pulse Laser (Large)	10	9	—	1-3	4-7	8-10	7	2	—	
Pulse Laser (Medium)	4	6	—	1-2	3-4	5-6	2	1	—	
Pulse Laser (Small)	2	3	—	1	2	3	1	1	—	
<i>Ballistic Weapons</i>										
Anti-Missile System	1	*	—	—	—	—	.5	1	12	
Autocannon/2	1	2	4	1-8	9-16	17-24	6	1	45	
Autocannon/5	1	5	3	1-6	7-12	13-18	8	4	20	
Autocannon/10	3	10	—	1-5	6-10	11-15	12	7	10	
Autocannon/20	7	20	—	1-3	4-6	7-9	14	10	5	
Flamer (Vehicle)	3	2	—	1	2	3	.5	1	20	
Gauss Rifle	1	15	2	1-7	8-15	16-22	15	7	8	
LB 10-X AC	2	10	—	1-6	7-12	13-18	11	6	10	
Machine Gun	0	2	—	1	2	3	.5	1	200	
Ultra AC/5	1	5	2	1-6	7-13	14-20	9	5	20	
<i>Missile Weapons</i>										
LRM 5	2	1/missile	6	1-7	8-14	15-21	2	1	24	
LRM 10	4	1/missile	6	1-7	8-14	15-21	5	2	12	
LRM 15	5	1/missile	6	1-7	8-14	15-21	7	3	8	
LRM 20	6	1/missile	6	1-7	8-14	15-21	10	5	6	
Narc Missile Beacon	0	—	—	1-3	4-6	7-9	3	2	6	
SRM 2	2	2/missile	—	1-3	4-6	7-9	1	1	50	
SRM 4	3	2/missile	—	1-3	4-6	7-9	2	1	25	
SRM 6	4	2/missile	—	1-3	4-6	7-9	3	2	15	
Streak SRM-2	2	*	—	1-3	4-6	7-9	1.5	1	50	
<i>Artillery Weapons*</i>										
Arrow IV System	10	20/10*	—	—	—	5 Maps	15	15	5	
Long Tom	20	20/10*	—	—	—	20 Maps	30	30	5	
Sniper	10	10/5*	—	—	—	12 Maps	20	20	10	
Thumper	6	5/2*	—	—	—	14 Maps	15	15	20	
<i>Other Equipment*</i>										
Artemis IV FCS	—	—	—	—	—	—	1	1	—	
Beagle Active Probe	—	—	—	—	—	4	1.5	2	—	
CASE	—	—	—	—	—	—	.5	1	—	
C3 Computer	—	—	—	—	—	—	5	5	—	
C3 Slave	—	—	—	—	—	—	1	1	—	
Double Heat Sink	-2	—	—	—	—	—	1	3	—	
Guardian ECM Suite	—	—	—	—	—	6	1.5	2	—	
Hatchet	0	*	—	—	—	—	***	***	—	
Heat Sink	-1	—	—	—	—	—	1	1	—	
MASC	—	—	—	—	—	—	**	**	—	
TAG	0	—	—	1-5	6-9	10-15	1	1	—	
Triple-Strength Myomer	*	—	—	—	—	—	0	6	—	

\*See special rules for this equipment.  
 \*\*Mech Tonnage + 20  
 \*\*\*Mech Tonnage + 15

## HEAT POINT TABLE

Activity	Heat Points
Walking	+1 per turn
Running	+2 per turn
Jumping	+1 per hex (minimum of 3 per turn)
Trying to Stand	+1 per attempt
Weapons Fire	Per Weapons and Equipment Tables
Heat Sink	-1 per operational heat sink -2 per operational double heat sink -1 additional per heat sink under water (6 HP maximum) -2 additional per double heat sink under water (6 HP maximum)
First Engine Hit	+5 per turn
Second Engine Hit	+10 (total) per turn
Fire	
Walking through	+2 per hex
Standing in	+5 per turn

## DIFFERENT ELEVATIONS TABLE

Target is:	Allowed Physical Attack
1 level higher	Charge, Punch (use Kick table), or Club (use Kick table)
1 level lower	Charge, Kick (use Punch table), or Club (use Punch table)

Note: A death from above attack can always be made if the BattleMech has the necessary Jumping MP.

## WEAPONS FIRE MODIFIERS TABLE

Attacker Movement	None
Stationary	None
Walked	+1
Ran	+2
Jumped	+3
BattleMech Damage	
Sensor Hit	+2
Shoulder	+4 for weapons in arm
Arm Actuator (each)	+1 for weapons in arm
Heat	
8-12	+1
13-16	+2
17-23	+3
24+	+4
Prone	+2
Range and Terrain	
Range	
Short	None
Medium	+2
Long	+4
Minimum Range	+1 at minimum range, additional +1 per hex less than minimum range
Light Woods	+1 per intervening hex; +1 if target in Light Woods
Heavy Woods	+2 per intervening hex; +2 if target in Heavy Woods
Water	
Depth 1	-1 to hit a BattleMech in Water hex; use BattleMech Punch Location Table: +1 to hit for BattleMech firing from Water hex
Depth 2	BattleMechs cannot fire into or out of Depth 2+ water
Target	
Partial Cover	+3 (use BattleMech Punch Location Table)
Prone	-2 from adjacent hex; +1 from all others
Secondary Target	+1
Immobile	-4
Movement	
Moved 0-2 hexes	0
Moved 3-4 hexes	+1
Moved 5-6 hexes	+2
Moved 7-9 hexes	+3
Moved 10+ hexes	+4
Jumped	+1

## BATTLEMECH HIT LOCATION TABLE

Dice Roll (2D6)	Left Side	Front/Rear	Right Side
2*	L. Torso (critical)	C. Torso (critical)	R. Torso (critical)
3	Left Leg	Right Arm	Right Leg
4	Left Arm	Right Arm	Right Arm
5	Left Arm	Right Leg	Right Arm
6	Left Leg	Right Torso	Right Leg
7	Left Torso	C. Torso	Right Torso
8	C. Torso	Left Torso	C. Torso
9	Right Torso	Left Leg	Left Torso
10	Right Arm	Left Arm	Left Arm
11	Right Leg	Left Arm	Left Leg
12	Head	Head	Head

\*A result of 2 may inflict a critical hit. Apply damage to the armor in that section in the normal manner, but the attacking player also rolls once on the Determining Critical Hits Table.

## BATTLEMECH KICK LOCATION TABLE

Die Roll	Result	Left Side	Front/Rear	Right Side
1-3	Left Leg	Left Leg	Right Leg	Right Leg
4-6	Left Leg	Left Leg	Left Leg	Right Leg

## MISSILE HITS TABLE

Dice Roll (2D6)	Number of Missiles Fired					
	2	4	5	6	10	15 20
2	1	1	1	2	3	5 6
3	1	2	2	2	3	5 6
4	1	2	2	3	4	6 9
5	1	2	3	3	6	9 12
6	1	2	3	4	6	9 12
7	1	3	3	4	6	9 12
8	2	3	3	4	6	9 12
9	2	3	4	5	8	12 16
10	2	3	4	5	8	12 16
11	2	4	5	6	10	15 20
12	2	4	5	6	10	15 20

## DETERMINING CRITICAL HITS TABLE

Dice Roll (2D6)	Effect
2-7	No Critical Hit
8-9	Roll 1 Critical Hit Location
10-11	Roll 2 Critical Hit Locations
12	Head/Limb Blown Off/Roll 3 Critical Hit Locations*

\*Roll 3 critical hit locations if the section struck is a torso.

## FACING AFTER A FALL TABLE

Die Roll (1D6)	New Facing	Hit Location
1	Same Direction	Front
2	1 Hexside Right	Right Side
3	2 Hexsides Right	Right Side
4	Opposite Direction	Rear
5	2 Hexsides Left	Left Side
6	1 Hexside Left	Left Side

## SKID MODIFIER TABLE

Hexes Moved	Piloting Skill Modifier
0-2	-1
3-4	0
5-7	+1
8-10	+2
11+	+4

## BUILDING MODIFIERS TABLE

Building Type	Original CF	MP Cost	Piloting Skill Modifier
Light	1-15	2	0
Medium	16-40	3	+1
Heavy	41-90	4	+2
Hardened	91-150	5	+5

## BUILDING MOVEMENT MODIFIERS TABLE

Hexes Moved in Turn	Piloting Skill Modifier
1-2	0
3-4	+1
5-6	+2
7-9	+3
10+	+4

## CLAN WEAPONS & EQUIPMENT TABLE

Type	Heat	Dam.	Range			Tons	Crit.	Ammo
			Min.	Short	Med.			
<b>Energy Weapons</b>								
ER Laser (Large)	12	10	—	1-8	9-15	16-25	4	1
ER Laser (Medium)	5	7	—	1-5	6-10	11-15	1	1
ER Laser (Small)	2	5	—	1-2	3-4	5-6	.5	1
ER PPC	15	15	—	1-7	8-14	15-23	6	2
Flamer	3	2	—	1	2	3	.5	1
Pulse Laser (Large)	10	10	—	1-6	7-14	15-20	6	2
Pulse Laser (Medium)	4	7	—	1-4	5-8	9-12	2	1
Pulse Laser (Small)	2	3	—	1-2	3-4	5-6	1	1
<b>Ballistic Weapons</b>								
Anti-Missile System	1	*	—	—	—	—	.5	1
Flamer (Vehicle)	3	2	—	1	2	3	.5	1
Gauss Rifle	1	15	2	1-7	8-15	16-22	12	6
LB 2-X AC	1	2	4	1-10	11-20	21-30	5	3
LB 5-X AC	1	5	3	1-8	9-15	16-24	7	4
LB 10-X AC	2	10	—	1-6	7-12	13-18	10	5
LB 20-X AC	6	20	—	1-4	5-8	9-12	12	9
Machine Gun	0	2	—	1	2	3	.25	1
Ultra AC/2	1	2	2	1-9	10-18	19-27	5	2
Ultra AC/5	1	5	—	1-7	8-14	15-21	7	3
Ultra AC/10	3	10	—	1-6	7-12	13-18	10	4
Ultra AC/20	7	20	—	1-4	5-8	9-12	12	8
<b>Missile Weapons</b>								
LRM 5	2	1/missile	—	1-7	8-14	15-21	1	1
LRM 10	4	1/missile	—	1-7	8-14	15-21	2.5	1
LRM 15	5	1/missile	—	1-7	8-14	15-21	3.5	2
LRM 20	6	1/missile	—	1-7	8-14	15-21	5	4
Narc Missile Beacon	0	NA	—	1-4	5-8	9-12	2	1
SRM 2	2	2/missile	—	1-3	4-6	7-9	.5	1
SRM 4	3	2/missile	—	1-3	4-6	7-9	1	1
SRM 6	4	2/missile	—	1-3	4-6	7-9	1.5	1
Streak SRM-2	2	*	—	1-4	5-8	9-12	1	1
Streak SRM-4	3	*	—	1-4	5-8	9-12	2	1
Streak SRM-6	4	*	—	1-4	5-8	9-12	3	2
<b>Artillery Weapons*</b>								
Arrow IV System	10	20/10*	—	—	—	6 Maps	12	12
Long Tom	20	20/10*	—	—	—	20 Maps	30	30
Sniper	10	10/5*	—	—	—	12 Maps	20	20
Thumper	6	5/2*	—	—	—	14 Maps	15	15
<b>Other Equipment*</b>								
Active Probe	—	—	—	—	—	5	1	1
Anti-Personnel Pod	0	*	—	—	—	—	.5	1
Artemis IV FCS	—	—	—	—	—	—	1	1
CASE	—	—	—	—	—	—	0	0
Double Heat Sink	-2	—	—	—	—	—	1	2
ECM Suite	—	—	—	—	—	6	1	1
Heat Sink	-1	—	—	—	—	—	1	1
MASC	—	—	—	—	—	—	**	**
TAG	0	—	—	1-5	6-9	10-15	1	1
Targeting Computer	—	—	—	—	—	—	*	*

\*See special rules for this equipment.  
\*\*Mech Tonnage ÷ 25

## MOVEMENT COST TABLE

Terrain Type/ Activity	MP Cost Per Hex	Prohibited Units
Clear	1	Naval
Road/Paved/Bridge	1 <sup>3</sup>	Naval
Rough	2	Wheeled, Naval
Light Woods	2	Wheeled, Hover, Naval
Heavy Woods	3	Ground, Naval
Water		
Depth 0	1	Naval
Depth 1	2 <sup>1</sup>	Infantry, Ground <sup>4</sup>
Depth 2+	4 <sup>1</sup>	Infantry, Ground <sup>4</sup>
Elevation/Depth Change (up or down)	+1/level (Mechs, VTOL, Subs) +2/level (Infantry, Ground)	
Rubble	2 <sup>1</sup>	Wheeled, Naval
Light Building	2 <sup>2</sup>	Naval
Medium Building	3 <sup>2</sup>	Naval
Heavy Building	4 <sup>2</sup>	Naval
Hardened Building	5 <sup>2</sup>	Naval
Other Activities		
Facing Change	1/hexside <sup>5</sup>	
Dropping to the Ground	1	
Standing Up	2/attempt	

- Piloting Skill Roll required to prevent falling.
- Piloting Skill Roll required to prevent damage; infantry pay only 1 MP to enter or leave any building.
- If traveling along road; otherwise cost of underlying terrain.
- Hovercraft may enter all water hexes.
- No cost for infantry.

## PILOTING SKILL ROLL TABLE

BattleMech's Situation	Modifier
Damage to BattleMech	
BattleMech takes 20+ Damage Points in one phase	+1
BattleMech reactor shuts down	+3 <sup>1</sup>
Leg/foot/hip actuator destroyed	+1
Gyro hit	+3
Gyro destroyed	Automatic Fall
Leg destroyed	Automatic Fall
Physical Attacks on BattleMech	
BattleMech was kicked	0
BattleMech was pushed	0
BattleMech was charged/death from above attack	+2
Unit's Actions	
BattleMech missed kick	0
BattleMech charging	+2
BattleMech death from above attack	+4 <sup>2</sup>
BattleMech entering Depth 1 Water hex	-1
BattleMech entering Depth 2 Water hex	0
BattleMech entering Depth 3+ Water hex	+1
BattleMech attempting to stand	0
BattleMech entering Rubble hex	0
Unit entering/leaving Light Building hex	0 <sup>3</sup>
Unit entering/leaving Medium Building hex	+1 <sup>3</sup>
Unit entering/leaving Heavy Building hex	+2 <sup>3</sup>
Unit entering/leaving Hardened Building hex	+5 <sup>3</sup>
Unit Skids	See Skid Modifier Table
BattleMech jumping with damaged leg actuators	per Additional Modifiers, below
MechWarrior trying to avoid damage when his BattleMech is falling	+1/ level fallen

- Only during the turn that the reactor shuts down. If the MechWarrior must make a Piloting Skill Roll for a Mech with a shut-down reactor, the BattleMech automatically falls.
- Automatic fall if death from above attack is unsuccessful.
- To avoid damage only. Does not result in a fall if Piloting Skill Roll fails. See Buildings.

Additional Modifiers	Modifier
Per leg/foot actuator previously destroyed	+1
Per hip also/previously destroyed	+2
Gyro also/previously hit (automatic fall if 2 previous hits)	+3
Leg previously destroyed	+5 <sup>4</sup>

<sup>4</sup>Do not add modifiers for the destroyed hip and other damaged actuators in the leg.

## BATTLEMECH PUNCH LOCATION TABLE

Die Roll (1D6)	Left Side	Front/Rear	Right Side
1	Left Torso	Left Arm	Right Torso
2	Left Torso	Left Torso	Right Torso
3	Center Torso	Center Torso	Center Torso
4	Left Arm	Right Torso	Right Arm
5	Left Arm	Right Arm	Right Arm
6	Head	Head	Head

## SPECIAL HIT LOCATION TABLE

Shot from Above	Die Roll (1D6)	Hit Location
	1	Left Arm
	2	Front/Rear Left Torso*
	3	Front/Rear Center Torso*
	4	Front/Rear Right Torso*
	5	Right Arm
	6	Head

Shot from Below	Die Roll (1D6)	Hit Location
	1	Left Leg
	2	Left Leg
	3	Front/Rear Left Torso*
	4	Front/Rear Right Torso*
	5	Right Leg
	6	Right Leg

\*The attack hits the Front if from the front or the side. It hits the Rear if from the rear.

## GROUND VEHICLE CRITICAL HITS TABLE

Die Roll (1D6)	Result
1	Crew stunned (No actions/next 2 turns)
2	Main weapon jams (No fire from largest system for 1 turn)
3	Engine hit (No movement/rest of game)
4	Crew killed (Vehicle out of game)
5	Fuel tank hit (Vehicle explodes)
6	Ammo/power plant hit (Vehicle explodes)

## GROUND VEHICLE HIT LOCATION TABLE

Dice Roll (2D6)	Front/Rear	Side
2	Armor (critical)	Armor (critical)
3	Armor <sup>1</sup>	Armor <sup>1</sup>
4	Armor <sup>2</sup>	Armor <sup>2</sup>
5	Armor <sup>3</sup>	Armor <sup>2</sup>
6	Armor	Armor
7	Armor	Armor
8	Armor	Armor
9	Armor	Armor <sup>3</sup>
10	Turret Armor	Turret Armor
11	Turret Armor <sup>4</sup>	Turret Armor <sup>4</sup>
12	Turret Armor (critical)	Armor (critical)

- A track, axle, or lift fan has been destroyed; the unit cannot move for the rest of the game. If a hovercraft suffers this hit while over water, it sinks and is destroyed.
- A drive, wheel, or airskirt has been damaged; -1 Cruising MP for the rest of the game.
- If the vehicle is a hovercraft, an airskirt has been damaged; -1 Cruising MP for the rest of the game. If not a hovercraft, no additional effect.
- The turret locks in its current position and cannot be moved for the rest of the game; it can only fire out of its current arc. If there is no turret, no additional effect.

Note: If there is no turret, then all turret hits become normal armor hits.



# MAP OF THE INNER SPHERE

## 3057

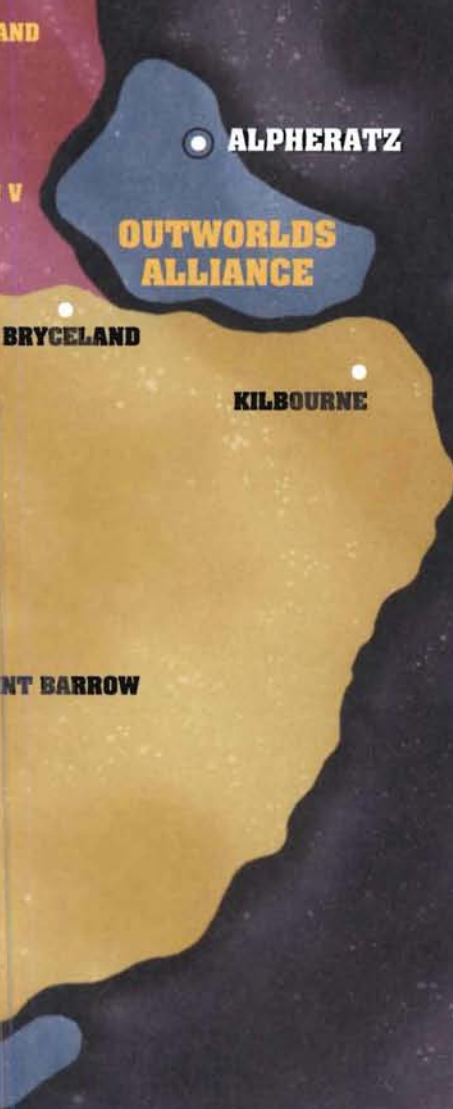

### TERRITORY MAP KEY



**JADE FALCON/  
STEEL VIPERS**



**WOLF CLAN**



**GHOST BEAR**



**SMOKE JAGUAR/  
NOVA CAT**



**LYRAN ALLIANCE**



**FREE RASALHAGUE  
REPUBLIC**



**FREE WORLDS LEAGUE**



**ST. IVES COMPACT**



**DRAGONIS COMBINE**



**FEDERATED  
COMMONWEALTH**



**CAPELLAN  
CONFEDERATION**

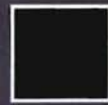

**DISPUTED  
(CHAOS MARCH)**